

DESCRIPTION

Thermatel TD1/TD2 switches can easily be adjusted to detect flow (gases and liquids), level or liquid-liquid interface. The TD1 is a 24 V DC line powered unit with integral electronics and a built-in DPDT relay. The TD2 is either V DC or V AC line powered, has integral or remote electronics and offers additionally LED indication, time delay and mA output for diagnostics and trending.

The Thermatel series has passed in-place cleanability testing according to the EHEDG procedure and does not contain any shadow area's that cannot be cleaned with standard spray balls. The TD2 is also available with a deep drawn 304 stainless steel hygienic housing.

FEATURES

- Easy field calibration – pre-calibration from factory at request.
- Variable flow or Flow/No flow detection of gases and liquids.
- Excellent low flow sensitivity.
- Automatic temperature compensation for repeatable alarm under varying process temperatures.
- Continuous diagnostics (sensor/electronics). Both the TD1 as the TD2 have automatic self diagnostics that continually check the operation of the switch. This insures that the switch is fully operational.
- Continuous monitoring of flow rate versus setpoint via LED (TD2).
- mA output provides repeatable indication of flow rate and fault detection (TD2).
- Flow can be measured over test points (TD2).
- Integral or remote electronics up to 150 m (500 ft).
- Suited for SIL1 loops (full FMEDA report available).



APPLICATIONS

Media: all types of gases and liquids.

Vessels: pipesizes down to 1/4". Max sensor length up to 3,3 m. Can be installed at any angle vertically/horizontally – flanged, threaded or with compression fitting – ask for bulletin 41-103.

Conditions: Can be used on conductive and non conductive media, very light density to heavy viscous media (up to 10.000 cP). Can be set to ignore foam, aeration, turbulence, and cavitation.

0,82 µm (RA 32) hygienic sensor finish



AGENCY APPROVALS^①

Model	Approval
TD1	II 1/2 G EEx d {ib} IIC T5, explosion proof (zone 0 & 1)
TD2	II 2 G EEx d IIC T5, explosion proof (zone 1)
CSA/FM ^②	Non incandive / explosion proof

^① For full ATEX approved product offer – Ask for bulletins 54-105 and 54-110.

Not available for units with hygienic housing.

^② Consult factory for proper partnumber.

PRINCIPLE OF OPERATION

The Thermatel electronics are either integral (TD1/TD2) or remote mounted (TD2) away from the sensor.

The sensing assembly contains 2 miniature RTD (Resistance Temperature Detector) tightly encased within a 316L stainless steel, Hastelloy C or Monel tube.

The first RTD (unheated) provides a reference temperature of the process conditions over the entire operating range of -70 °C to +200 °C (-100 °F to +400 °F).

The second RTD is internally heated to establish a temperature differential above the process temperature. The cooling effect on the heated RTD, caused by the presence of flow or level, decreases the differential temperature between the two RTD's. The change in differential temperature is then converted to the actuation of the alarm/control relay and non-linear mA output (TD2).

Flow

No Flow/Low Flow
In the absence of flow/low flow, the self-heated sensor creates a temperature differential between the two sensors.

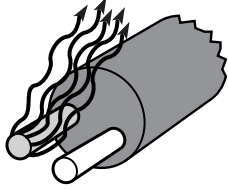
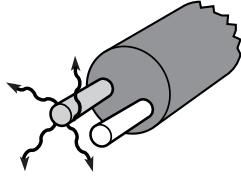

Flow
As media flow increases across the sensing assembly, heat is dissipated and temperature differential decreases .

Level

Low Level
In the absence of media, the self-heated sensor tip creates a temperature differential between the two sensors.

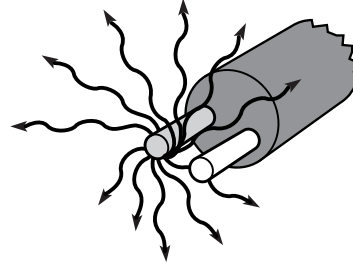
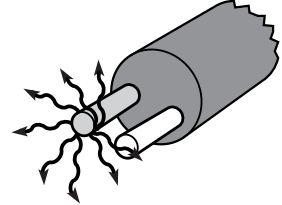

High Level
As media contacts the sensing assembly, heat is absorbed by the fluid, decreasing the temperature differential.

TEMPERATURE COMPENSATION

The alarm point of thermal dispersion switches has previously been affected by changing temperatures. With the TD1/TD2, the effect of changing process temperature has been greatly reduced.

No temperature compensation

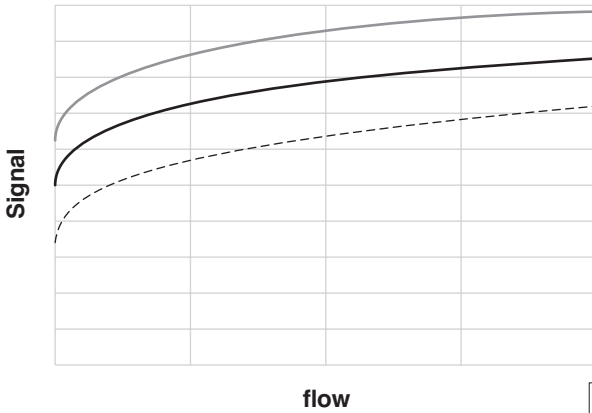

With temperature compensation

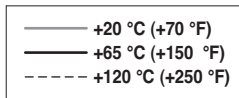
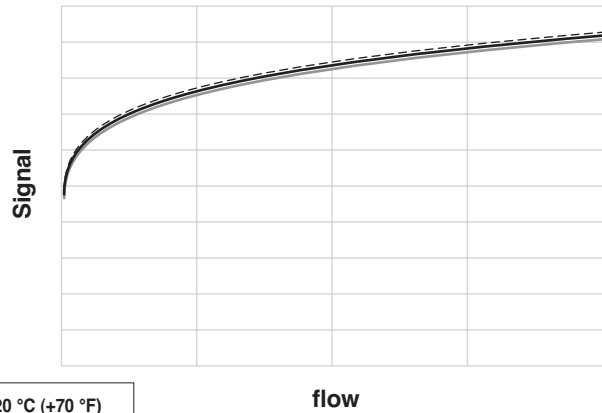

FLOW BEHAVIOUR

Typical air flow

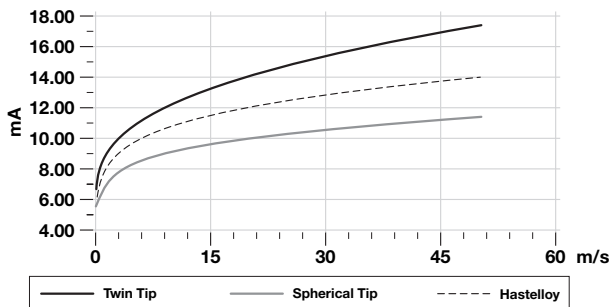

Typical water flow

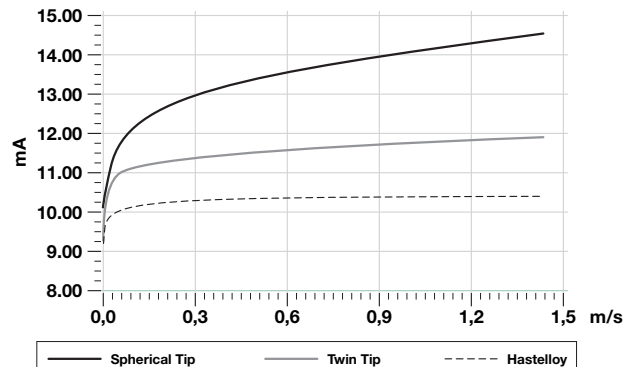

APPLICATIONS

APPLICATIONS FLOW

Thermatel® TD1/TD2 switches may be installed in a variety of flow applications as shown in the illustration below. Flow/No Flow can be detected in an input line to a primary tank, or in an output line. They may be installed for overflow detection in a pipe connected to an overflow tank or installed in a drain line for Wet/Dry indication. In addition, due to the capability to detect liquids or gases, the Thermatel® flow switch may be installed in a gas vent to detect off-gas from the primary tank.

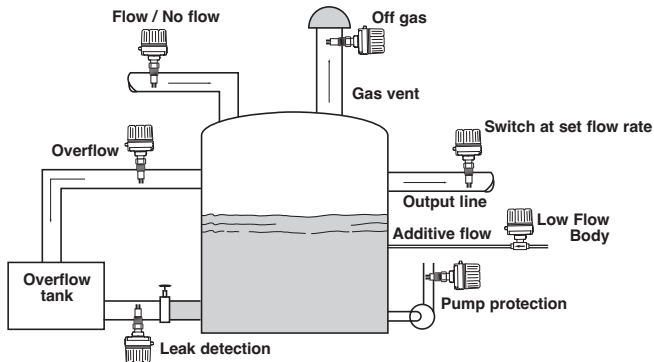

- Liquid or Gas flow detection
- Maintain a minimum flow rate
 - Pump protection
 - Cooling air/water
 - Lubrication systems
 - Chemical feed pumps
- Detect presence of flow
 - Relief valves
 - Flare lines

APPLICATIONS LEVEL

Thermatel® series TD1/TD2 switches can be installed in a variety of level applications as shown in the illustration below. High or low level alarm applications can be installed in either vertical or horizontal mountings.

Sensors are available in lengths from 50 to 3300 mm (2" to 130") for a wide variety of applications.

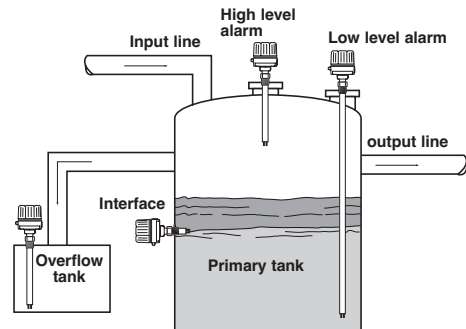

- High level
- Low level
- Interface between different liquids
 - Oil/water
 - Liquid/foam
- Suitable for any liquid level detection including:
 - High viscosity
 - High solids content
 - Aeration
 - Foam
- Insensitive to dielectric, specific gravity, viscosity
- Sanitary applications

PUMP PROTECTION

Installed on the suction or discharge of a pump, a Thermatel switch provides rapid indication of a low flow or no flow condition to prevent pump damage. No moving parts, excellent low flow sensitivity, and low hysteresis between alarm and reset points are all important features in this application. Enhanced temperature compensation minimizes set point drift due to varying process temperatures.

ADDITIONAL APPLICATIONS

Flow Switch

- Water for Injection
- CIP Systems
- CO2 Flow

Level Switch

- High Viscosity

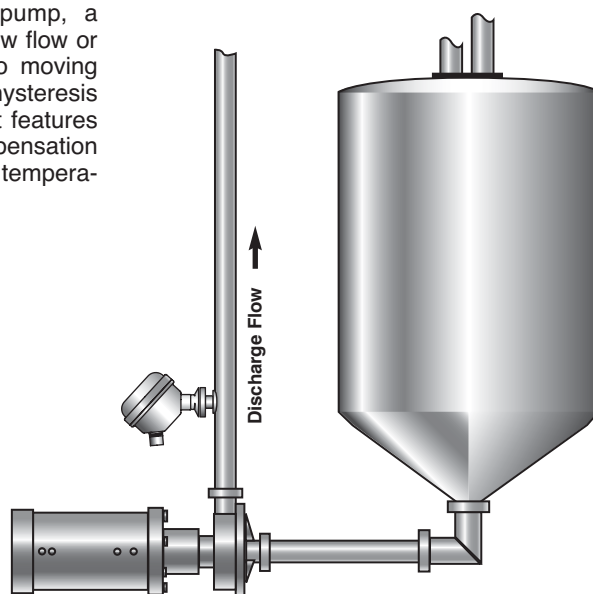

Sanitary centrifugal pump protection

EXPEDITE SHIP PLAN (ESP)

Several Thermatel switches are available for quick shipment, within max. 4 weeks after factory receipt of purchase order, through the Expedite Ship Plan (ESP).

Models covered by ESP service are conveniently colour coded in the selection data charts.

To take advantage of ESP, simply match the colour coded model number codes (standard dimensions apply).

ESP service may not apply to orders of ten units or more. Contact your local representative for lead times on larger volume orders, as well as other products and options.

SELECTION DATA

A complete Thermatel® system consists of:

1. THERMATEL® electronics
2. THERMATEL® sensor (see pages 7, 9 and 10)
3. Optional: Mounting flanges (compatible with 3/4" threaded sensors)
4. Optional: Factory calibration, consult factory

ELECTRONICS

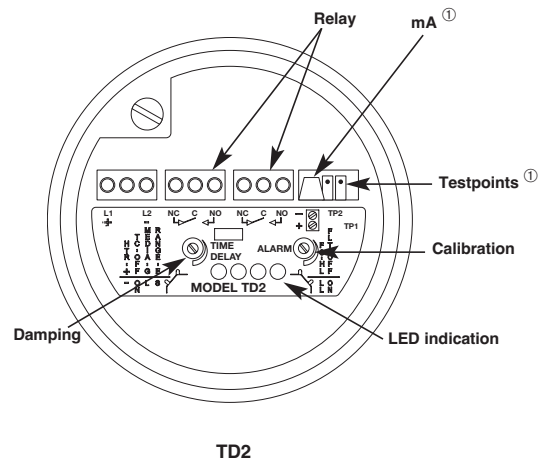
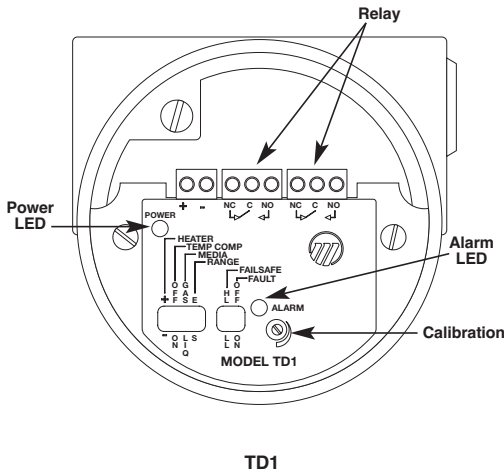

TD1 main features:

Alarm/Fault indication:

Alarm relay de-energizes and red LED:

- turns on (alarm)
- blinks (fault).

Factory calibration:

TD1/TD2 can be delivered pre-calibrated at a fixed setpoint. TD2 can be delivered with a complete calibration curve, allowing the customer to field adjust the setpoint by using a voltmeter at the test points.

TD2 features:

mA output

- for trending: the calibrated setpoint corresponds with a specific mA value but although not linear, it provides important process information. With increasing flow or immersed sensor, the mA signal increases.
- for diagnostics: either 3.6 mA (Low level) or 22 mA (High level/flow failsafe) output, indicates for an instrument failure (electronics/sensor).

Test points:

Allow the user to periodically check the setpoint and verify for set point drift. The setpoints read voltage units.

LED indication:

The LED's show progressively actual flow/level versus the calibrated setpoint.

Typical mA signals

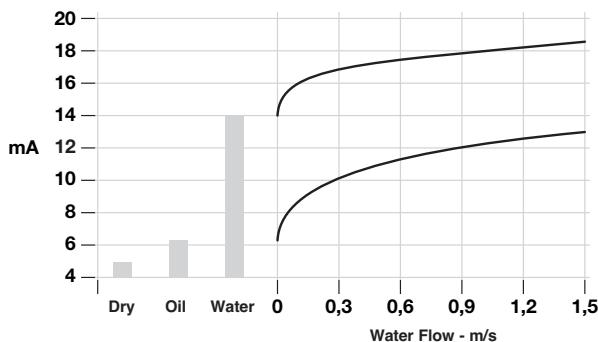

① (not for all models - see amplifier part number on page 5)

1. Order code for Thermatel® TD1 electronics

T D 1 - 2 D 0 0 - 0	Thermatel TD1 electronics, 24 V DC for flow, level and interface Integral mount electronics with 8 A DPDT relay
---------------------	--

Approvals

3	General purpose / FM-CSA explosion proof
C	ATEX explosion proof (zone 0 and 1)

Housing

0	IP66, Cast aluminium housing with 3/4" NPT entry (2 entries - one plugged)
1	IP66, Cast aluminium housing with M20 x 1,5 entry (2 entries - one plugged)

TD1 is not available with the hygienic stainless steel housing

T	D	1	-	2	D	0	0	-	0		
---	---	---	---	---	---	---	---	---	---	--	--

complete order code for Thermatel® TD1 electronics

1. Order code for Thermatel® TD2 electronics

T D 2	Thermatel TD2 Electronics with continuous LED indication and mA output
-------	--

POWER

7	240 V AC (100-264 V AC)
8	24 V DC (± 20 %)

OUTPUT

D 0	8 A DPDT relay
H 0	1 A Hermetically sealed DPDT relay ^①

^① requires for ATEX 1G / zone 0 applications a TMC/TMD/TMH sensor with 1 mm wall thickness

ACCESSORIES

0	Blind housing cover
1	Housing cover with glass window

HOUSING TYPE

0 7 4	Hygienic housing - IP67, 304 SST, 1/2" NPT cable entry (single entry)
0 7 5	Hygienic housing - IP67, 304 SST, M20 x 1,5 cable entry (2 entries - one plugged)
0 3 0	General purpose housing - IP66, Cast aluminium, 3/4" NPT cable entry (2 entries - one plugged)
0 3 1	General purpose housing - IP66, Cast aluminium, M20 x 1,5 cable entry (2 entries - one plugged)
0 G 0	ATEX Exd housing - IP66, Cast aluminium, 3/4" NPT cable entry (2 entries - one plugged)
0 G 1	ATEX Exd housing - IP66, Cast aluminium, M20 x 1,5 cable entry (2 entries - one plugged)

NOTE: Consult bulletin 54-110 for remote housing options.

T	D	2				0			0		
---	---	---	--	--	--	---	--	--	---	--	--

complete order code for Thermatel® TD2 electronics

PRESSURE/TEMPERATURE RATING

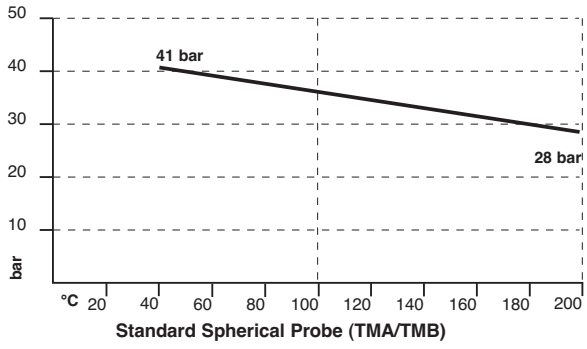

DIMENSIONS IN MM (INCHES)

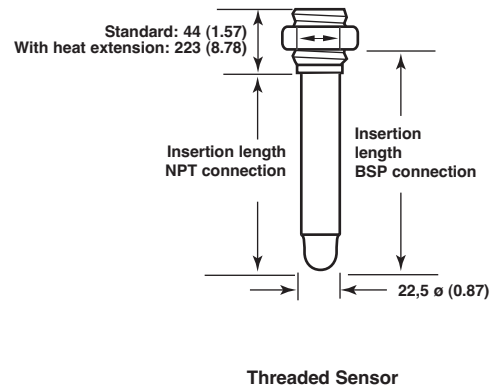
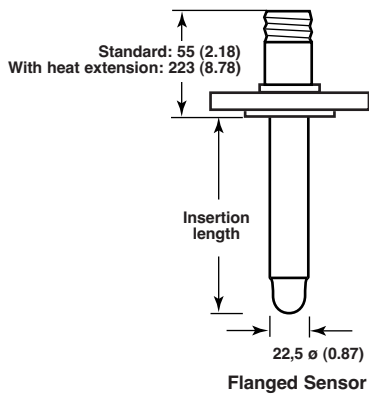

CONNECTIONS

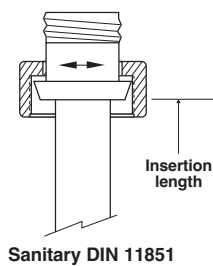
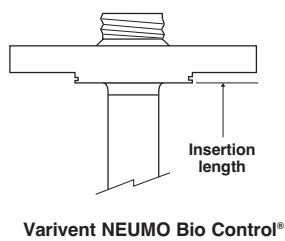
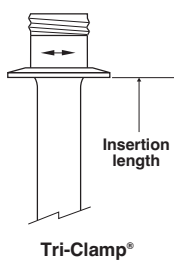
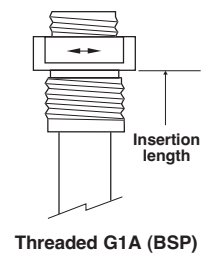
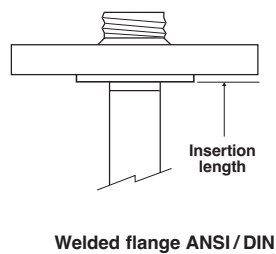
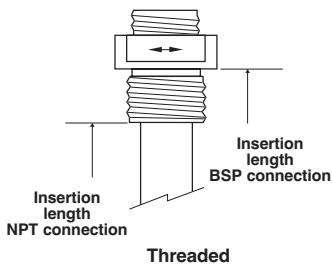

SELECTION DATA (CONT.)

2. Order code for Thermatel® TD1/TD2 – STANDARD SENSOR

BASIC MODEL NUMBER – SENSOR^①

T M A	Standard spherical tip	max +120 °C (+250 °F) / max 41 bar (600 psi)
T M B	Standard spherical tip - with heat extension	max +200 °C (+400 °F) / max 41 bar (600 psi)

^① Consult sales bulletin BE 54-110 for industrial type sensor options.

MATERIAL OF CONSTRUCTION FOR SENSOR AND PROCESS CONNECTION

A	316/316 L (1.4401/1.4404) stainless steel
---	---

PROCESS CONNECTION SIZE

1	1	Threaded 3/4" NPT
2	1	Threaded 1" NPT
2	2	Threaded G1 (1" BSP)
2	P	Threaded G1A (BSP) - compatible with sanitary weld flange

SANITARY FLANGED

3	T	1" and 1 1/2"	Tri-Clamp®
4	T	2"	Tri-Clamp®
B	S	DIN 11.851	DN 25
C	S	DIN 11.851	DN 40
D	S	DIN 11.851	DN 50

V	V	Varivent	DN 65
B	N	NEUMO Bio Control®	D 25
D	N	NEUMO Bio Control®	D 50
V	N	NEUMO Bio Control®	D 65

ANSI FLANGED

2	3	1"	150 lbs ANSI RF flange
2	4	1"	300 lbs ANSI RF flange
3	3	1 1/2"	150 lbs ANSI RF flange
3	4	1 1/2"	300 lbs ANSI RF flange
4	3	2"	150 lbs ANSI RF flange
4	4	2"	300 lbs ANSI RF flange

EN/DIN FLANGED

B	B	DN 25	PN 16/25/40	EN 1092-1	Type A
C	B	DN 40	PN 16/25/40	EN 1092-1	Type A
D	A	DN 50	PN 16	EN 1092-1	Type A
D	B	DN 50	PN 25/40	EN 1092-1	Type A

INSERTION LENGTH – SPECIFY FOR INCREMENTS OF 10 mm (0.39")

0	0	5	Minimum length 50 mm (2")
0	0	8	Minimum length 80 mm (3") – sensors with BSP (G1) connection
3	3	0	Maximum length 3300 mm (130")



complete order code for TD1/TD2 Thermatel® STANDARD SENSOR

DIMENSIONS IN MM (INCHES) – TML

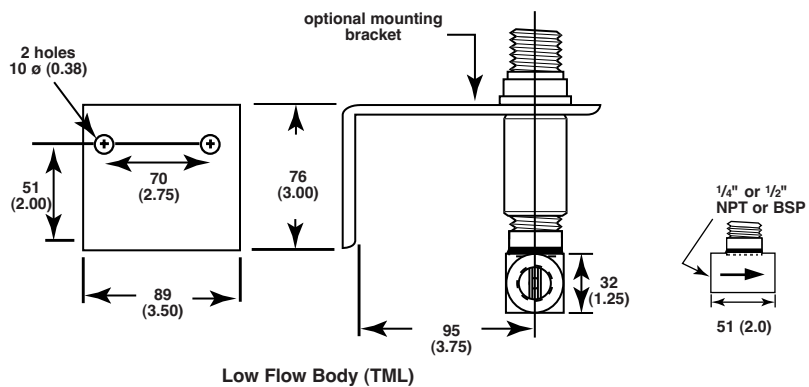

PRESSURE/TEMPERATURE – TML

Max 285 bar (4100 psi) @ max +120 °C (+250 °F)

Max 400 bar (5800 psi) @ +40 °C (100 °F).

RECOMMENDED FLOW RANGES

Size	Water	Air
1/4" flow body	0,02 to 5,7 l/h (0.0055 GPH to 1.5 GPH)	0,006 Nm ³ /h to 5,75 Nm ³ /h (100 sccm to 200 SCFH)
1/2" flow body	0,04 to 11,5 l/h (0.01 GPH to 3 GPH)	0,015 Nm ³ /h to 11,5 Nm ³ /h (250 sccm to 400 SCFH)

SELECTION DATA (CONT.)

2. Order code for Thermatel® TD1/TD2 – LOW FLOW BODY SENSOR

T	M	L	Low flow body – max +120 °C (+250 °F) / max 400 bar (5800 psi)
---	---	---	--

MATERIAL OF CONSTRUCTION FOR SENSOR AND PROCESS CONNECTION

A	316/316 L (1.4401/1.4404) stainless steel
---	---

PROCESS CONNECTION SIZE

T	1	Threaded 1/4" NPT
V	1	Threaded 1/2" NPT
T	0	Threaded G 1/4 (1/4" BSP)
V	0	Threaded G 1/2 (1/2" BSP)

MOUNTING BRACKET

0	0	0	None
1	0	0	With carbon steel mounting bracket

T	M	L	A		0		
---	---	---	---	--	---	--	--

complete order code for TD1/TD2 Thermatel® LOW FLOW BODY SENSOR

SELECTION DATA (CONT.)

2. Order code for Thermatel® TD1/TD2 – MINI SENSOR

T M M	Mini twin tip (16 mm diam.) – max +120 °C (+250 °F) / max 207 bar (3000 psi) for standard sensor length max +120 °C (+250 °F) / max 127 bar (1850 psi) for sensors ≥ 50 mm (2")
-------	--

MATERIAL OF CONSTRUCTION FOR SENSOR AND PROCESS CONNECTION

A	316/316 L (1.4401/1.4404) stainless steel
---	---

PROCESS CONNECTION SIZE

0	1	Threaded 1/2" NPT
1	1	Threaded 3/4" NPT
2	1	Threaded 1" NPT

INSERTION LENGTH – SPECIFY FOR INCREMENTS OF 10 mm (0.39")

0	0	3	Standard length 25 mm (1")
0	0	5	Minimum selectable length 50 mm (2")
3	3	0	Maximum selectable length 3300 mm (130")

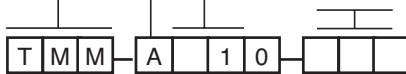

complete order code TD1/TD2 Thermatel® MINI SENSOR

DIMENSIONS IN MM (INCHES)

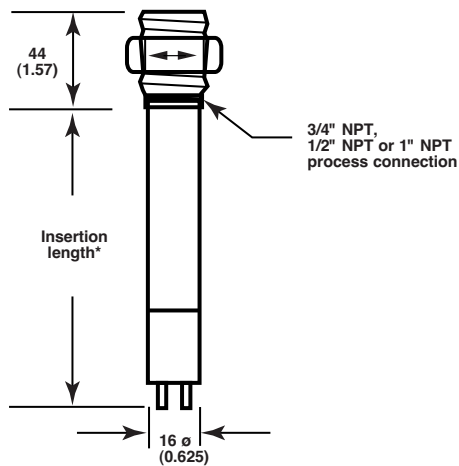

Mini Sensor (TMM)

PRESSURE/TEMPERATURE RATING

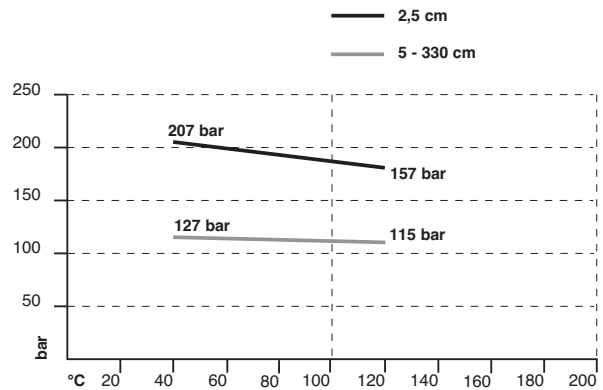

RECOMMENDED FLOW RANGES

Size	Water	Air
1/2" "T"	0,75 to 680 l/h (0.2 GPH to 180 GPH)	0,85 to 120 Nm³/h (0.5 to 70 SCFM)
3/4" "T"	2 to 900 l/h (0.5 GPH to 240 GPH)	2,5 to 170 Nm³/h (1.5 to 100 SCFM)
1" "T"	3,8 to 1600 l/h (1 GPH to 420 GPH)	5 to 290 Nm³/h (3 to 170 SCFM)

ELECTRONICS SPECIFICATIONS

Description		TD1	TD2
Power at terminals		19.2 to 28.8 V DC	19.2 to 28.8 V DC 100 to 264 V AC, 50-60 Hz
Power consumption		3,5 W @ 24 V DC	4 W @ 24 V DC or 5 W @ 264 V DC
Flow range		Standard sensors: 0,003 to 1,5 m/s (0.01 to 5.0 FPS) – water 0,03 to 150 m/s (0.1 to 500 FPS) – air 1/4" Low flow body: 0,02 to 5,7 l/h – water and min 0,006 Nm ³ /h – air/gases 1/2" Low flow body: 0,04 to 11,5 l/h – water and min 0,015 Nm ³ /h – air/gases	
Signal output	Alarm	8 A DPDT relay @ 30 V DC	8 A DPDT relay @ 30 V DC / 250 V AC 1 A HS DPDT relay @ 28 V DC
	Continuous	Not applicable	non linear mA for trending (not for all models - see amplifier part number on page 5)
	Error	Via alarm relay	3.6 mA (Low FS) – 22 mA (High FS) and alarm relay
Damping		Not available	0 to 100 s (in addition to sensor response)
User interface		Local switches for gain setting, function setting and Hi/Lo failsafe Calibration and damping via potentiometer	
Display		LED's for Power/Alarm status	2 green LED's (safe condition), 1 yellow LED (alarm setpoint being approached) 1 red LED (alarm condition)
Approvals		ATEX II 2 G EEx d IIC T5, explosion proof - TD2 for zone 1 ATEX II 1/2 G EEx d IIC T5, explosion proof - TD1 for zone 0 and 1 EHEDG certification (per TNO report # V4772/03) CSA/FM: Non incendive / explosion proof	
SIL (Safety Integrity Level)		Functional safety to SIL1 as 1oo1 in accordance to IEC 61508 – SFF of 69,3 % (TD1) and 73 % (TD2) – full FMECA reports and declaration sheets available	
Housing materials		IP66, Cast aluminium epoxy coated or IP67, 304 stainless steel deep drawn	
Net and gross weight		2 kg (4.6 lbs) with 50 mm (2") sensor - aluminium housing 1 kg (2.2 lbs) with 50 mm (2") sensor - hygienic housing	

PERFORMANCE

Description	Specification
Response time	1-10 s typical (dependant on sensor type, application and set point)
Repeatability	< 1 % @ constant °C
Ambient temperature	-40 to +70 °C (-40 to +158 °F) – operational -50 to +76 °C (-58 to +170 °F) – storage
Humidity	0-99 % non condensing
Electromagnetic compatibility	Meets CE requirements (EN 61326: 1997 + A1 + A2) and Namur NE 21

SENSOR SPECIFICATIONS

Description	Spherical sensors TMA/TMB	MINI twin tip sensor TMM	Low flow body TML
Materials	316/316L (1.4401/1.4404)	316/316L (1.4401/1.4404)	316/316L (1.4401/1.4404)
Sanitary finish	0.82 µm (RA 32) – consult factory for electropolishing		not applicable
Sensor / pipe diameter	22,5 mm (0.87")	16 mm (0.63")	1/4" or 1/2"
Process connection	Threaded: 1/2" NPT (TMM only), 3/4" NPT, 1" NPT, G1 (1" BSP), G1A Flanged: ANSI, EN/DIN or hygienic		F- 1/4" or 1/2" NPT or BSP
Probe length	5 - 330 cm (2" - 130")	2,5 - 150 cm (1" - 60")	Not applicable
Max process temperature ^①	TMA -70 to +120 °C (-100 to 250 °F) TMB -70 to +200 °C (-100 to 400 °F)	-70 °C to +120 °C (-100 °F to +250 °F)	-70 °C to +120 °C (-100 °F to +250 °F)
Max process pressure	TMA/TMB: 41 bar (600 psi)	25 mm sensor: 207 bar (3000 psi) > 25 mm sensor: 127 bar (1850 psi)	400 bar (5800 psi)
Recommended for	TMA: for liquid flows / suitable for gas flow – resists heavy coating TMB: same as TMA but can be used up to +200 °C (+400 °F) process temperature TMM: for direct mounting in "T" pieces on small pipe sizes – light coating TML: for the detection, control of extreme low flows, resists light coating		

DIMENSIONS IN MM (INCHES)

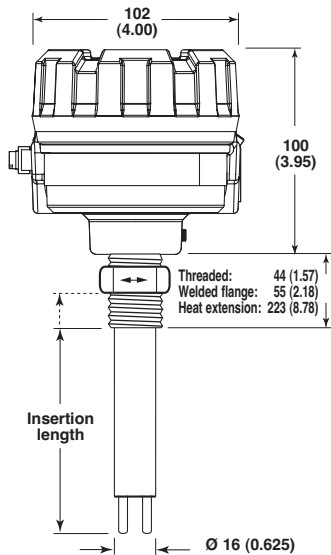

Model TD1 with TMM Mini Twin Tip Sensor

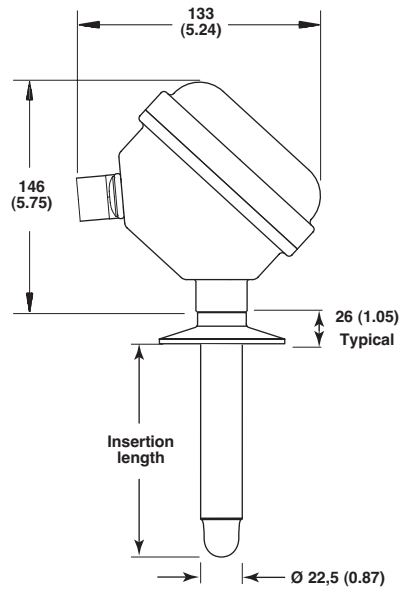

Model TD2
Integral electronics
with TMA Spherical Tip Sensor

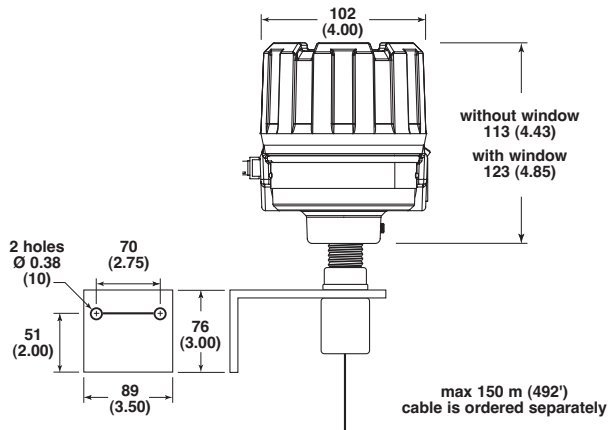

Model TD2 with Remote electronics

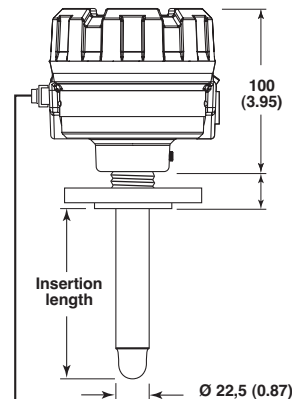

Remote TMC Spherical Tip Probe
with Flange Connection



QUALITY ASSURANCE - ISO 9001:2000

THE QUALITY ASSURANCE SYSTEM IN PLACE AT MAGNETROL GUARANTEES THE HIGHEST LEVEL OF QUALITY DURING THE DESIGN, THE CONSTRUCTION AND THE SERVICE OF CONTROLS. OUR QUALITY ASSURANCE SYSTEM IS APPROVED AND CERTIFIED TO ISO 9001:2000 AND OUR TOTAL COMPANY IS COMMITTED TO PROVIDING FULL CUSTOMER SATISFACTION BOTH IN QUALITY PRODUCTS AND QUALITY SERVICE.

PRODUCT WARRANTY

ALL MAGNETROL ELECTRONIC AND ULTRASONIC LEVEL CONTROLS ARE WARRANTED FREE OF DEFECTS IN MATERIALS AND WORKMANSHIP FOR ONE FULL YEAR FROM THE DATE OF ORIGINAL FACTORY SHIPMENT. IF RETURNED WITHIN THE WARRANTY PERIOD; AND, UPON FACTORY INSPECTION OF THE CONTROL, THE CAUSE OF THE CLAIM IS DETERMINED TO BE COVERED UNDER THE WARRANTY; THEN, MAGNETROL INTERNATIONAL WILL REPAIR OR REPLACE THE CONTROL AT NO COST TO THE PURCHASER (OR OWNER) OTHER THAN TRANSPORTATION. MAGNETROL SHALL NOT BE LIABLE FOR MISAPPLICATION, LABOR CLAIMS, DIRECT OR CONSEQUENTIAL DAMAGE OR EXPENSE ARISING FROM THE INSTALLATION OR USE OF THE EQUIPMENT. THERE ARE NO OTHER WARRANTIES EXPRESSED OR IMPLIED, EXCEPT, SPECIAL WRITTEN WARRANTIES COVERING SOME MAGNETROL PRODUCTS.



BULLETIN N°:
EFFECTIVE:
SUPERSEDES:

BE 54-160.0
APRIL 2008
New

UNDER RESERVE OF MODIFICATIONS

BENELUX FRANCE	Heikensstraat 6, 9240 Zele, België - Belgique Tél. +32 (0)52.45.11.11 • Fax. +32 (0)52.45.09.93 • E-Mail: info@magnetrol.eu
DEUTSCHLAND	Alte Ziegelei 2-4, D-51491 Overath Tel. +49 (0)2204 / 9536-0 • Fax. +49 (0)2204 / 9536-53 • E-Mail: vertrieb@magnetrol.de
INDIA	C-20 Community Centre, Janakpuri, New Delhi - 110 0058 Tel. +91 (11) 41661840 • Fax +91 (11) 41661843 • E-Mail: info@magnetrolindia.com
ITALIA	Via Aresè 12, I-20159 Milano Tel. +39 02 607.22.98 (R.A.) • Fax. +39 02 668.66.52 • E-Mail: mit.gen@magnetrol.it
U.A.E.	DAFZA Office 5EA 722 • PO Box 293671 • Dubai Tel. +971-4-6091735 • Fax +971-4-6091736 • E-Mail: info@magnetrol.ae
UNITED KINGDOM	Unit 1 Regent Business Centre, Jubilee Road Burgess Hill West Sussex RH 15 9TL Tel. +44 (0)1444 871313 • Fax +44 (0)1444 871317 • E-Mail: sales@magnetrol.co.uk

www.magnetrol.com

OUR NEAREST REPRESENTATIVE