

DESCRIPTION

Thermatel Model TA2 Thermal Mass Flow Transmitter provides reliable mass measurement for air and gas flow applications. The powerful, yet easy to use, electronics are contained in a compact explosion proof enclosure. The TA2 offers excellent performance at exceptional value.

FEATURES

- Direct mass flow measurement of air and gases.
- No need for temperature/pressure correction.
- High turndown ratio 100:1.
- Excellent low flow sensitivity.
- Low pressure drop.
- Flow, temperature and totalized flow available over HART®.
- Advanced diagnostics check condition of probe, electronics, and wiring.
- Rotatable plug in display module provides display of flow rate, temperature, totalized flow, plus diagnostic messages and integrates four push button keypad for ease of configuration.
- Process temperatures up to +200 °C (+400 °F).
- Pressure rating to 103 bar (1500 psig) dependent upon process connections.
- Probe can be field replaced.
- Sensor is protected to prevent damage if inserted too far into pipe.
- Optional:
 - hot tap retractable probe assembly or valve with compression fitting
 - flow body for 1/2" to 4" pipe sizes
 - flow conditioning plate for flow bodies 1 1/2" and higher.
- Suited for SIL 1 and SIL 2 loops (full FMEDA report available).



APPLICATIONS

- Combustion air
- Digester/Bio-gas
- Compressed air/gas
- Vent lines/flare headers
- Natural gas
- Hydrogen piping
- Aeration lines

For air and gases

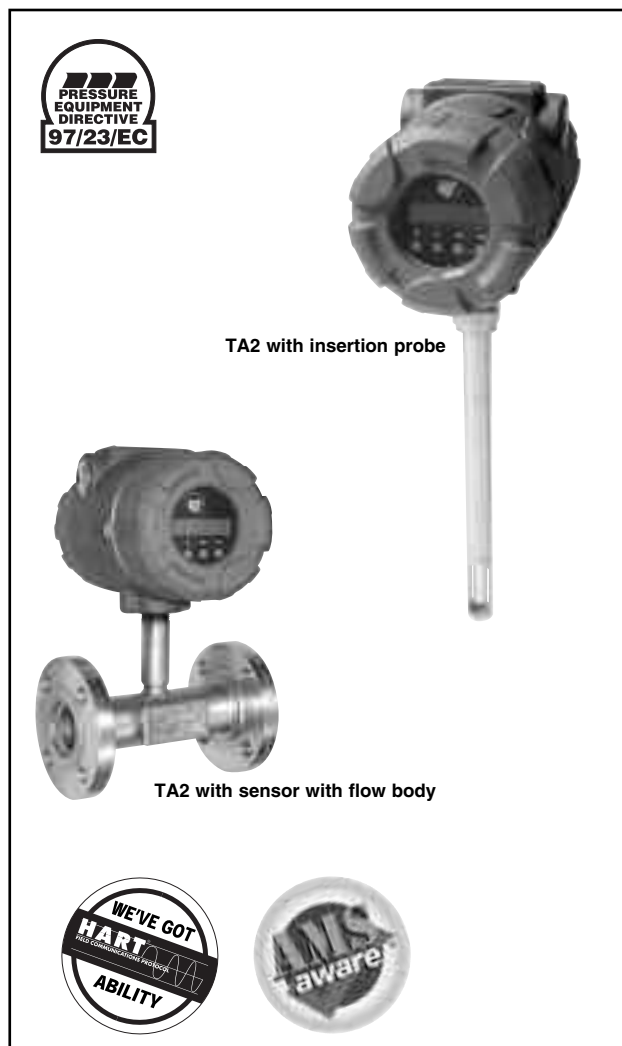

AGENCY APPROVALS

Agency	Approval
ATEX	ATEX II 2G EEx d II C T6, explosion proof
FM/CSA	Non Incendive Explosion proof (Groups B, C and D)
RosTechnadzor / GOST-R	Russian Authorisation Standards

PRINCIPLE OF OPERATION

Thermatel Model TA2 flow transmitter measures mass flow by detecting heat dissipation from a heated surface. The sensor contains two mass balanced elements with precision matched RTD's. The reference sensor measures the process temperature (up to +200° C [+400° F]); the second RTD measures the temperature of the heated sensor. The power to the heater is varied to maintain a constant temperature difference above the reference temperature. There is an inherent non-linear relationship between power and mass flow. The microprocessor in the TA2 compares the power against the calibration curve and converts the power requirements to the mass flow rate. Temperature is also measured to provide temperature compensation of the mass flow over the operating range of the instrument.

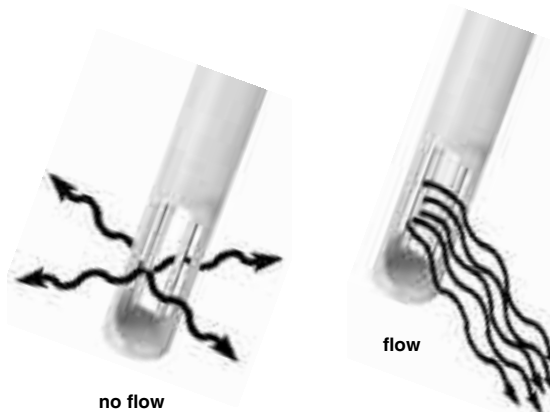

ADDITIONAL FEATURES

TEMPERATURE COMPENSATION

Thermal flow technology measures the mass flow rate without the need for pressure and temperature correction as required with most gas flow instruments that measure the flow rate at actual conditions. However, changing temperature will change the properties of the gas which effect convective heat transfer. The Model TA2 measures the temperature and automatically corrects the mass flow measurement for changes in gas properties over the entire temperature range of the instrument.

TOTALIZER

The software totalizer provides a nine-digit display of the total flow in the user's choice of engineering units. The use of EEPROM for storage of totalized data eliminates the need for backup batteries, and provides maximum safeguard of data in the event of a power interruption. The totalizer can be reset using the display module or HART.

SELECTABLE STP CONDITIONS (Normalized conditions)

The TA2 directly measures mass flow of the gas at Standard Temperature and Pressure (STP) conditions. Software permits the user to change STP conditions for their own requirements.

DIAGNOSTICS

Diagnostics is an important aspect of the TA2. The unit has the ability to check the probe status and indicate either normal operation, short or open circuit in the PT 1000, or heater circuit.

In order to verify that the calibration and configuration match the original calibration conditions, the user can select a specific signal and compare the TA2 display value against the original calibration certificate.

AREA COMPENSATION FOR PIPE SIZE

Insertion of the sensor into a pipe reduces the flow area, thus increasing the velocity for a given flow rate. The TA2 automatically compensates the flow measurement based on actual area of the pipe. The user simply enters the size or the area of the pipe, and the instrument automatically compensates the flow measurement for the probe blockage.

AIR EQUIVALENCY

Using historic air-gas calibration data, an air equivalency calibration can be performed on select gases. Consult your Magnetrol contact for details and flow ranges.

PROBE INSTALLATION

Probes can be provided with a variety of process connections, including threads, flanges, or installation through a compression fitting. The sensor will fit pipe sizes of 1 1/2" diameter or larger (2"/DN 50 minimum size with thread connection).

The sensor is protected to prevent damage due to "bottoming-out" if inserted too far into a pipe. When using an insertion probe with compression fitting, the user can adjust the position of the sensor in the pipe to obtain the optimum location. Typically, this will be with the bottom of the probe 25 mm (1.0") lower than the center line of the pipe.

PORTABLE DISPLAY MODULE

A portable display module for configuration and diagnosis of multiple units is available (part number 089-5219-001). This portable module plugs into the electronics in the same manner as the normal display and uses the same software menu. This module permits the user to reduce installation cost by having one display module with keypad for multiple TA2 units.

Usage of the display module requires that the housing cover be removed during use and thus may not be useable in hazardous areas. In these cases, the HART option should be utilized.

PROBE SIMULATION MODULE

The Model TA2 has an optional probe simulation module (part number 089-5220-001). Using this module, the user can disconnect the probe from the electronics and verify the operation of the transmitter electronics against a known standard.

FACTORY CALIBRATION AND CONFIGURATION

Each TA2 is calibrated at the factory for the type of gas and the specified flow rate. The instrument is configured for the specific application information. The result is an instrument which can be installed and immediately be placed into operation without field setup.



Portable display module

APPLICATIONS

COMPRESSED AIR/GASES

Measurement of mass flow in different gas lines to determine in plant usage for internal allocation.

Advantages:

- direct mass flow
- high turndown rates
- flow totalization
- easy installation

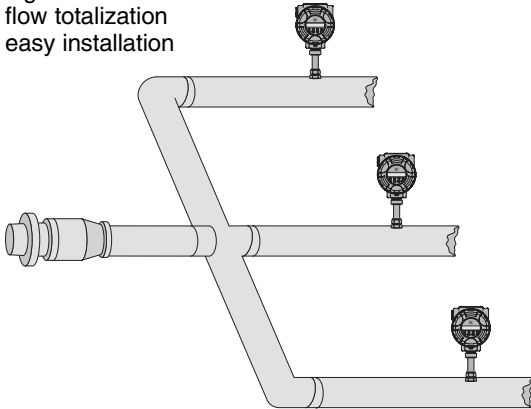

FLARE LINES

Measurement of flow in different sections of flare line.

Advantages:

- good low flow sensitivity
- high turndown
- easy removal if cleaning is required

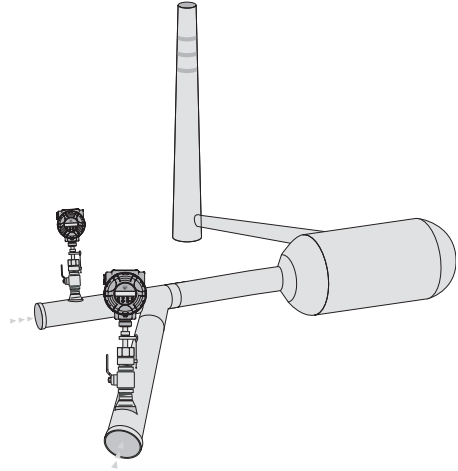

BOILER COMBUSTION

The TA2 measures the inlet air flow to the boiler. This signal is sent to the DCS where it is used to trim the natural gas flow.

Advantages:

- mass flow measurement
- repeatable flow signal
- high rangeability

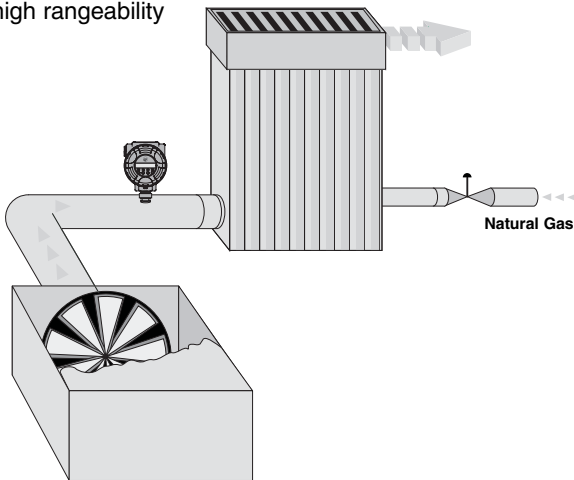

AERATION AIR FLOW

Measurement and balance of the flow to each section of the aeration basin in waste water treatment plants.

Advantages:

- low installation cost
- direct mass flow
- high reliability

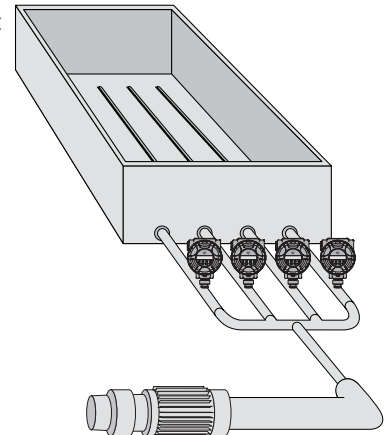

NATURAL GAS FLOW

The Model TA2 efficiently measures the flow and totalized flow of fuel to furnaces, heaters, or boilers. This data may be used for internal allocation or to report emission rates.

Advantages:

- direct mass flow in Nm³/h
- built in totalizer
- easy in setup and operation

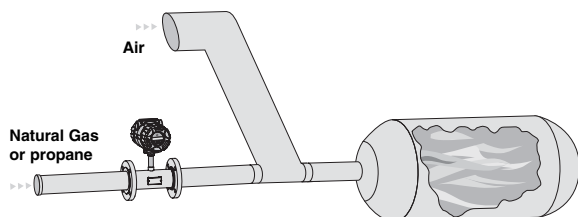

DIGESTER GAS/BIO-GAS

The off gas from a digester contains a mixture of methane and carbon dioxide saturated with moisture. This is a difficult flow measurement due to low flow rate and low pressures.

Advantages:

- excellent low flow sensitivity
- high turndown rates
- provides measurement of flow and totalized flow

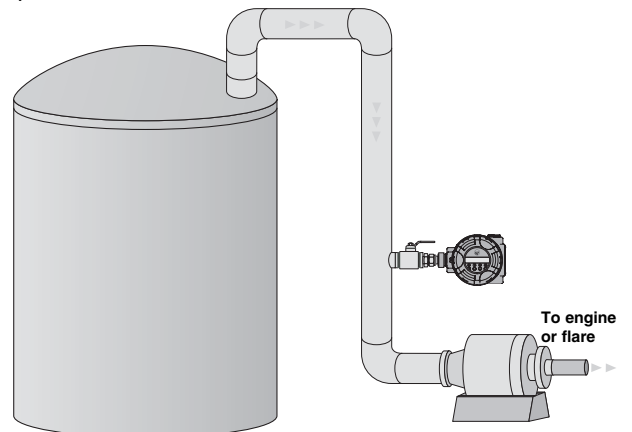

DIMENSIONS IN mm (inches)

Integral Mount TA2

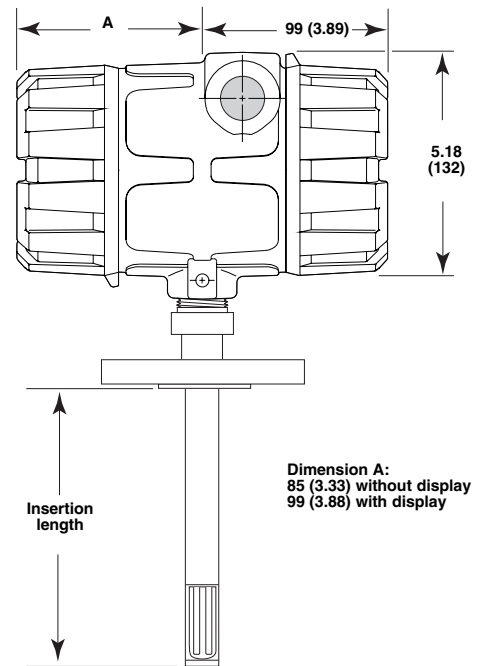
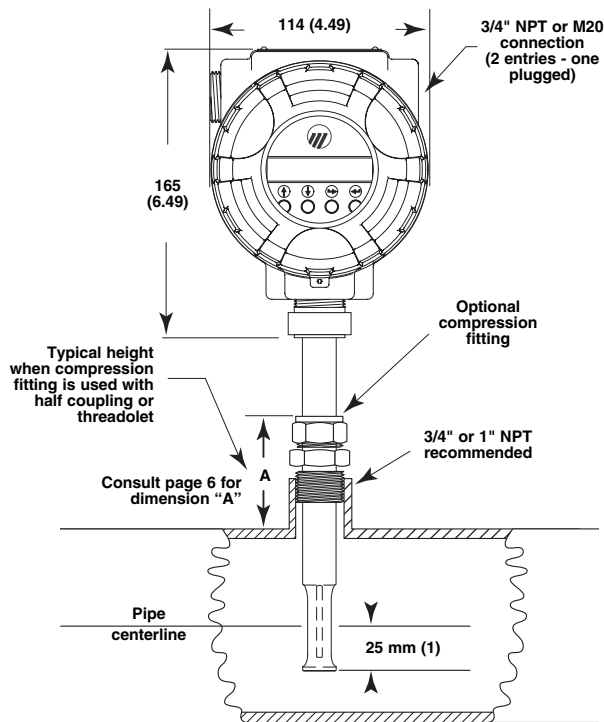

Remote Mount TA2

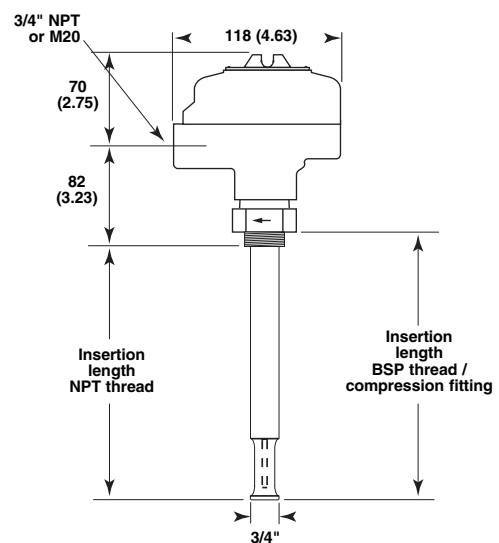
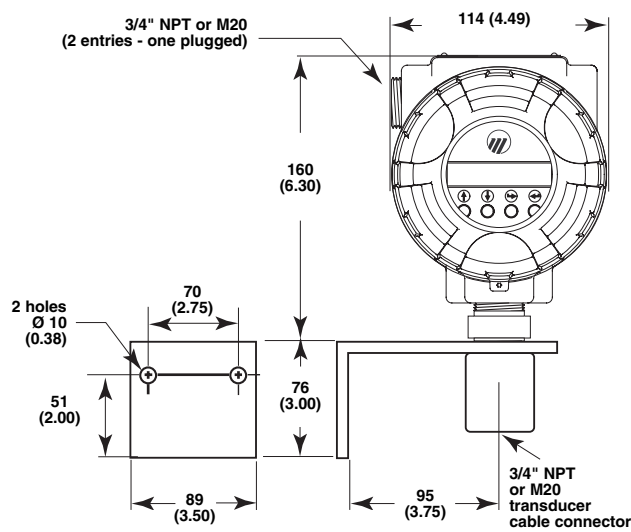

SELECTION DATA

A complete measuring system consists of:

1. Thermatel® TA2 mass flow electronics.
Thermatel® TA2 mass flow transmitters require an application report for performing pre-calibration from factory. Ask your magnetrol® contact for assistance when specifying a device.
2. Thermatel® TA2 mass flow insertion probe or Thermatel® TA2 mass flow sensor with flow body.
3. Connecting cable for remote mount Thermatel® TA2 mass flow transmitters
4. Options:
 - portable display module – order number: **089-5219-001** (for more details see page 2)
 - probe simulation module – order number: **089-5220-001** (for more details see page 2)
 - retractable probe assembly (RPA) – for order code see page 10
 - valve and compression fitting – order number: **089-5218-001** (for more details see page 10)
 - duct mounting bracket – order number: **089-7247-001** (for more details see page 4)
 - compression fittings – for order code see page 6.

1. Order code for Thermatel® TA2 mass flow transmitter

BASIC MODEL NUMBER

T	A	2	Thermatel® TA2 Mass Flow transmitter
---	---	---	--------------------------------------

INPUT VOLTAGE

2	24 V DC
1	240 V AC
0	120 V AC

SIGNAL OUTPUT

1	4-20 mA with HART communication
---	---------------------------------

ACCESSORIES

0	Blind transmitter (can receive the plug in display as future option)
B	Plug in digital display and keypad

MENU LANGUAGE (HART communication is only available in English language)

1	English
3	French
4	German

ACTUAL GAS CALIBRATION

For TA2 with insertion probe

0	Special. Specify medium separately
1	Air
2	Nitrogen or Oxygen
3	Hydrogen

4	Natural gas
5	Methane
6	Digester gas
7	Propane

For TA2 with sensor with flow body

A	Special. Specify medium separately
B	Air
C	Nitrogen or Oxygen
D	Hydrogen

E	Natural gas
F	Methane
G	Digester gas
H	Propane

AIR EQUIVALENCY CALIBRATION

Air equivalency values are available for various gases, consult factory for gases and flow rates.

9	For TA2 with insertion probe
K	For TA2 with sensor with flow body

MOUNTING/CLASSIFICATION (Consult factory for FM/CSA approvals)

3	Integral, General Purpose (FM/CSA explosion proof)
4	Remote, General Purpose (FM/CSA explosion proof)*
C	Integral, ATEX II 2G EEx d II C T6, explosion proof
D	Remote, ATEX II 2G EEx d II C T6, explosion proof*

* Bracket for electronics and probe housing included

HOUSING MATERIAL / CABLE ENTRY

1	IP 66, Cast aluminium - M20 x 1,5 cable entry (2 entries - one plugged)
0	IP 66, Cast aluminium - 3/4" NPT cable entry (2 entries - one plugged)

T	A	2	1						
---	---	---	---	--	--	--	--	--	--

complete order code for Thermatel® TA2 Mass Flow transmitter

DIMENSIONS IN mm (inches)

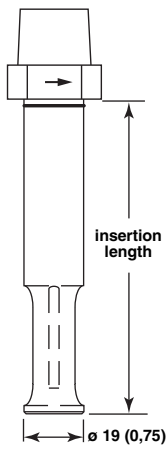

TMR for mounting with compression fitting

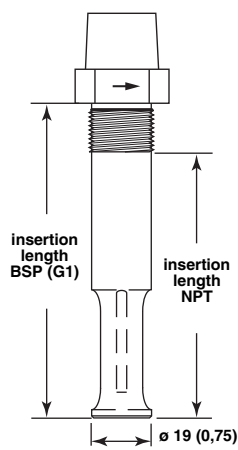

TMR with threaded connection

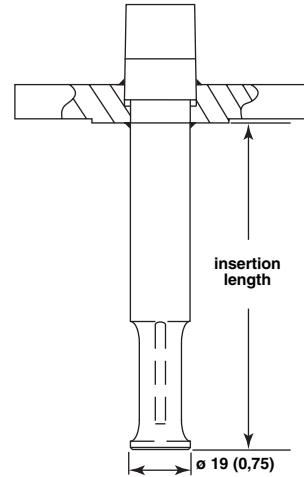

TMR with flanged connection

Process Conn. Size	Height A	Compression fitting	
		Teflon ferrules	Stainless steel ferrules
1" NPT	79 (3.1)	011-4719-009 (6,90 bar maximum)	011-4719-007 (69 bar maximum)
3/4" NPT	66 (2.6)	011-4719-008 (6,90 bar maximum)	011-4719-006 (69 bar maximum)

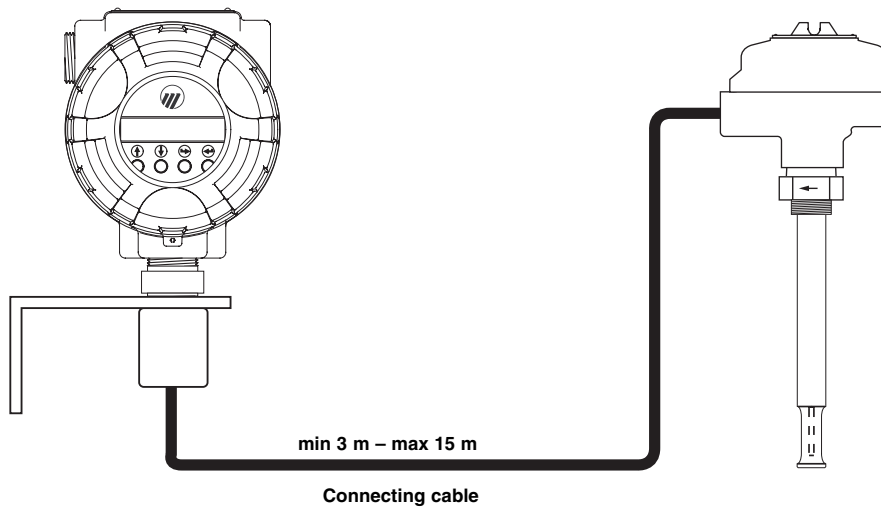

ELECTRICAL WIRING

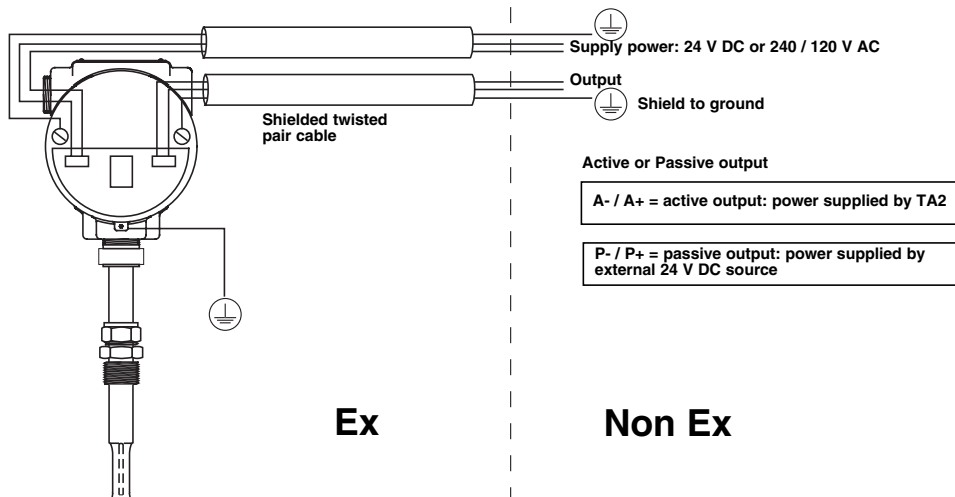

SELECTION DATA

2. Order code for Thermatel® TA2 mass flow insertion probe

BASIC MODEL NUMBER

T M R	Thermatel® TA2 Mass Flow probe
-------	--------------------------------

MATERIALS OF CONSTRUCTION

A	316/316L (1.4401/14404) stainless steel
B	Hastelloy C (2.4819) - not available with compression fitting

PROCESS CONNECTION

0 0 0	Compression fitting - min 11 cm insertion length (compression fittings are not included, for proper order numbers – see page 6). Only available with 316/316L (1.4401/1.4404). Consult factory for Hastelloy C (2.4819)
-------	---

Threaded

1 1 0	3/4" NPT - default selection in combination with a retractable probe assembly (RPA) see page 6
2 1 0	1" NPT
2 2 0	1" BSP (G1)

ANSI flanges

2 3 0	1"	150 lbs - RF flange
2 4 0	1"	300 lbs - RF flange
3 3 0	1 1/2"	150 lbs - RF flange
3 4 0	1 1/2"	300 lbs - RF flange
4 3 0	2"	150 lbs - RF flange
4 4 0	2"	300 lbs - RF flange

EN/DIN flanges

B A 0	DN 25	PN 16	EN 1092-1 Type A
B B 0	DN 25	PN 25/40	EN 1092-1 Type A
C A 0	DN 40	PN 16	EN 1092-1 Type A
C B 0	DN 40	PN 25/40	EN 1092-1 Type A
D A 0	DN 50	PN 16	EN 1092-1 Type A
D B 0	DN 50	PN 25/40	EN 1092-1 Type A

INSERTION LENGTH - consider process connections

Min probe length

0 0 7	7 cm (2,6") fix length - for NPT threaded
0 0 9	9 cm (3,5") fix length - for BSP threaded

Selectable probe length - specify per 1 cm (0,39") increments

0 0 9	min. 9 cm (3,5") - for NPT threaded and flanged
0 1 1	min. 11 cm (4,5") - for BSP threaded and compression fitting
0 2 5	min. 25 cm (10") - for use with RPA (Retractable Probe Assembly)
2 5 3	max. 253 cm (99,9") - for all probe connections

T	M	R				0		
---	---	---	--	--	--	---	--	--

complete order code for Thermatel® TA2 mass flow insertion probe

3. Order code for connecting cable remote mount Thermatel® TA2 mass flow transmitter

0 3 7 - 3 3 1 4	General purpose connecting cable - 8 wire shielded instrument cable
0 0 9 - 8 2 7 0	ATEX explosion proof connecting cable - 8 wire shielded instrument cable

CABLE LENGTH - specify per 1 m (3.28') increments

0 0 3	min 3 m (10') length
0 1 5	max 15 m (50') length

0							
---	--	--	--	--	--	--	--

complete order code for connecting cable

DIMENSIONS IN mm (inches)

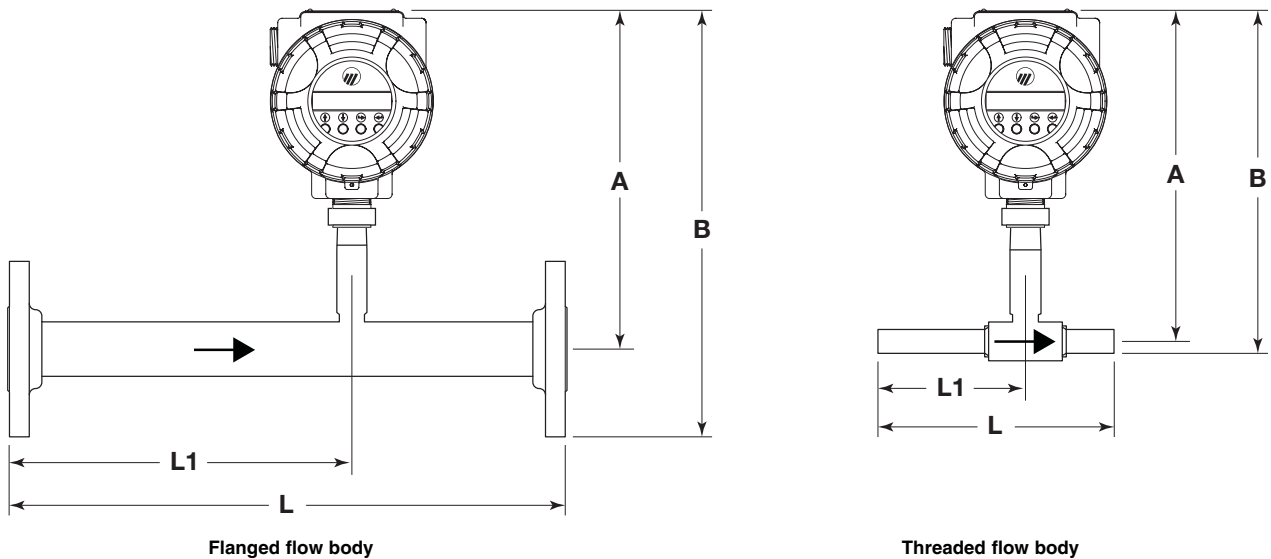

Code	Size	Length (L)		L1		Height to Centerline (A) mm (inches)	Overall Height (B)	
		With Flow Conditioning mm (inches)	Without Flow Conditioning mm (inches)	With Flow Conditioning mm (inches)	Without Flow Conditioning mm (inches)		NPT-F mm (inches)	Flange mm (inches)
0	1/2"	203 (8) ^①	—	127 (5) ^①	—	203 (8.0)	221 (8.7)	248 (9.75)
1	3/4"	286 (11.25) ^①	—	190 (7.5) ^①	—	203 (8.0)	221 (8.7)	251 (9.9)
2	1"	381 (15) ^①	—	254 (10) ^①	—	203 (8.0)	221 (8.7)	257 (10.1)
3	1 1/2"	495 (19.5)	191 (7.5)	305 (12)	95 (3.75)	212 (8.35)	236 (9.3)	276 (10.85)
4	2"	660 (26)	191 (7.5)	406 (16)	95 (3.75)	235 (9.25)	264 (10.4)	311 (12.25)
5	3"	991 (39)	254 (10)	610 (24)	127 (5)	235 (9.25)	N/A	330 (13.0)
6	4"	1321 (52)	305 (12)	914 (36)	152 (6)	235 (9.25)	N/A	349 (13.75)

^① The upstream length in pipe sizes < 1 1/2" dia. is sufficient to create the flow conditioning effect without need for a flow conditioning plate.

Flow body sizing

The following table is a general guide on flow sizing. Contact your Magnetrol contact for specific application information.

Code	Size	Max flow rate					
		Air, N ₂ , O ₂	Natural Gas, Methane	Digester Gas	Propane	Hydrogen	CO ₂ , Argon
0	1/2"	110 NM ³ /h 65 SCFM	76 NM ³ /h 45 SCFM	42 NM ³ /h 25 SCFM	51 NM ³ /h 30 SCFM	27 NM ³ /h 15 SCFM	105 NM ³ /h 60 SCFM
1	3/4"	204 NM ³ /h 120 SCFM	140 NM ³ /h 85 SCFM	76 NM ³ /h 45 SCFM	93 NM ³ /h 55 SCFM	52 NM ³ /h 30 SCFM	190 NM ³ /h 110 SCFM
2	1"	340 NM ³ /h 200 SCFM	238 NM ³ /h 140 SCFM	127 NM ³ /h 75 SCFM	161 NM ³ /h 95 SCFM	85 NM ³ /h 50 SCFM	320 NM ³ /h 190 SCFM
3	1 1/2"	833 NM ³ /h 490 SCFM	580 NM ³ /h 340 SCFM	310 NM ³ /h 180 SCFM	395 NM ³ /h 230 SCFM	208 NM ³ /h 120 SCFM	790 NM ³ /h 465 SCFM
4	2"	1220 NM ³ /h 715 SCFM	855 NM ³ /h 505 SCFM	480 NM ³ /h 280 SCFM	600 NM ³ /h 350 SCFM	332 NM ³ /h 195 SCFM	1155 NM ³ /h 680 SCFM
5	3"	3000 NM ³ /h 1765 SCFM	2110 NM ³ /h 1240 SCFM	1180 NM ³ /h 695 SCFM	1470 NM ³ /h 860 SCFM	812 NM ³ /h 475 SCFM	2855 NM ³ /h 1680 SCFM
6	4"	5490 NM ³ /h 3230 SCFM	3845 NM ³ /h 2260 SCFM	2145 NM ³ /h 1265 SCFM	2675 NM ³ /h 1575 SCFM	1478 NM ³ /h 865 SCFM	5210 NM ³ /h 3060 SCFM

SELECTION DATA

2. Order code for Thermatel® TA2 sensor with flow body

BASIC MODEL NUMBER

T F T	Thermatel® TA2 sensor with mass flow body
-------	---

MATERIALS OF CONSTRUCTION

A	316/316L (1.4401/1.4404) stainless steel body and sensor
1	Carbon steel body / stainless steel sensor

THREADED FLOW BODY - ø size and connection

0	1	1/2"	NPT
1	1	3/4"	NPT
2	1	1"	NPT
3	1	1 1/2"	NPT
4	1	2"	NPT

FLANGED FLOW BODY - ø size and connection

0	3	1/2"	150 lbs RF flange
1	3	3/4"	150 lbs RF flange
2	3	1"	150 lbs RF flange
3	3	1 1/2"	150 lbs RF flange
4	3	2"	150 lbs RF flange
5	3	3"	150 lbs RF flange
6	3	4"	150 lbs RF flange

Accessoires

0	None
1	Stainless steel flow conditioning plate - for flow body sizes $\geq 1\frac{1}{2}$ "

T	F	T					0	0	0
---	---	---	--	--	--	--	---	---	---

complete order code for Thermatel® TA2 sensor with flow body

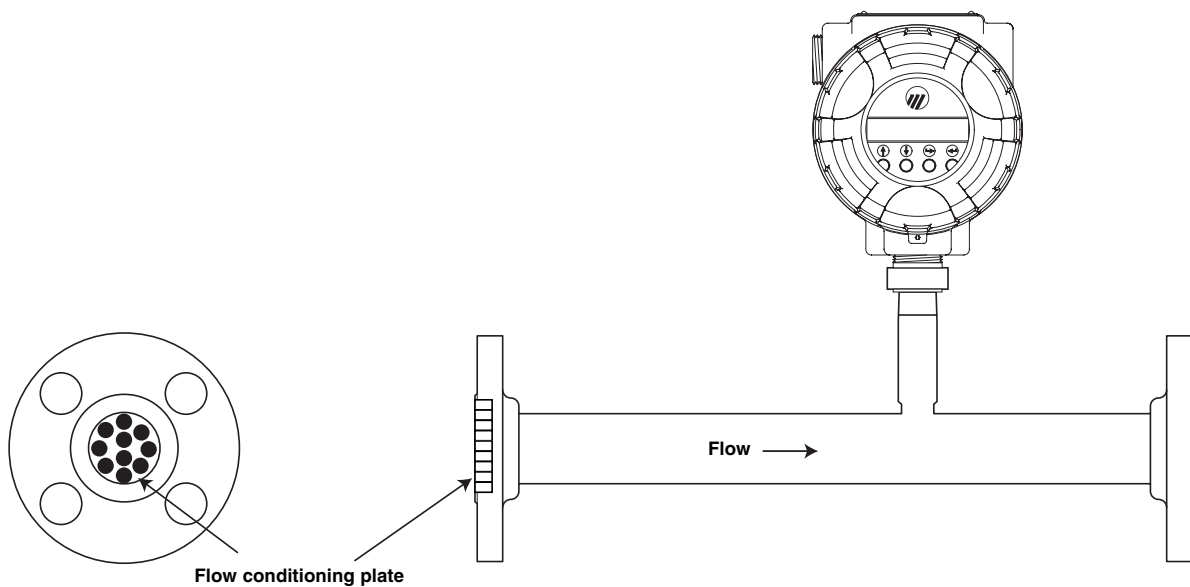

SELECTION DATA

4. Order code for retractable probe assembly

BASIC MODEL NUMBER

R	P	A	Retractable probe assembly
---	---	---	----------------------------

DESIGN TYPE

E	Low pressure - up to 5,5 bar (80 psi)
F	High pressure - up to 300 lbs / service

MATERIALS OF CONSTRUCTION

1	Carbon steel with 316 SST (1.4401) seal gland
4	316 SST (1.4401)

PROCESS CONNECTION

0	1 1/2" NPT	- not available for RPA-E1
1	1 1/2" - 150 lbs RF flange	
2	1 1/2" - 300 lbs RF flange	

BALL VALVE

0	No ball valve supplied	
1	Carbon steel ball valve	- select material code 1
2	Stainless steel ball valve	- select material code 4

PROBE LENGTH

0	2	5	min 25 cm (10")
2	5	3	max 253 cm (99,9")

R	P	A							
---	---	---	--	--	--	--	--	--	--

complete order code for retractable probe assembly

High Pressure RPA

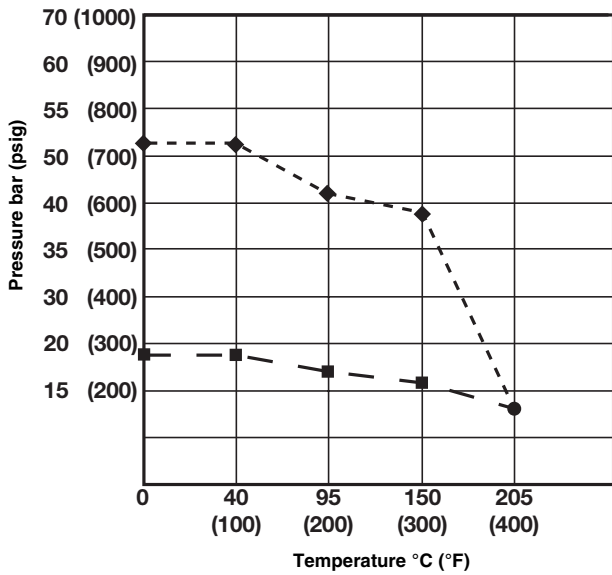

■ 150 lb. flange ◆ Threaded or 300 lb. flange

Hot Tap retractable probe assembly

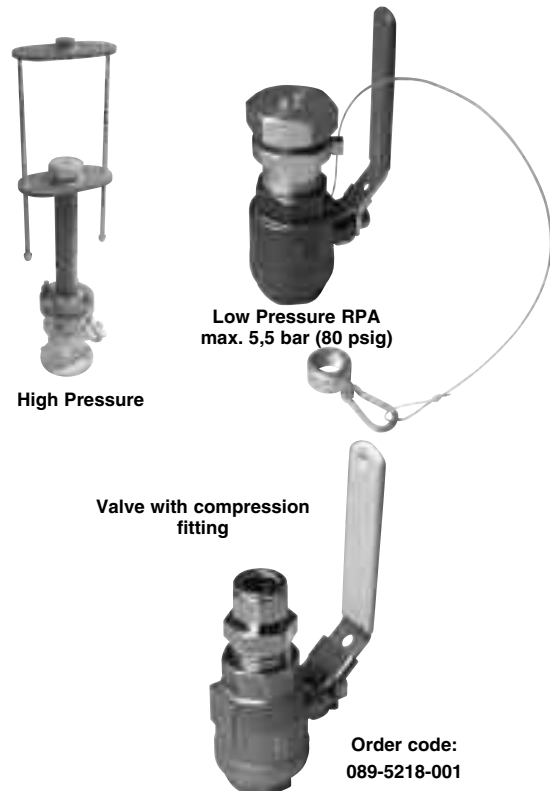

Order code:
089-5218-001

TRANSMITTER SPECIFICATIONS

FUNCTIONAL/PHYSICAL

<i>Description</i>		<i>Specification</i>
Power supply		19 – 29 V DC 204 – 260 V AC, 50-60 Hz 102 – 132 V AC, 50-60 Hz
Power consumption		6 W – 9 V A
Signal Output	Active	4-20 mA isolated (3,8 – 20,5 mA useable as per NAMUR NE 43) - max 1000 Ω loop resistance
	Passive	4-20 mA isolated (3,8 – 20,5 mA useable as per NAMUR NE 43) - max loop resistance depending power supply
Resolution	Analog	0,01 mA
	Display	0,01 Nm/s
Calibration		Pre-calibrated from factory - NIST traceable
Damping		Adjustable 0-15 s time constant
Diagnostic Alarm		Adjustable 3,6 mA, 22 mA or Hold
User Interface		4-button keypad and/or HART® communicator
Display		2-line x 16-character LCD
Displayed values		Flow (eg. Nm ³ /h, NI/h) and/or mass flow (eg. kg/h) and/or temperature (°C/°F) and/or loop current (mA) and/or totalized flow (eg. Nm ³ /h, NI/h)
Menu Language		English, French or German
Housing Material		IP 66, Aluminium A 356 (< 0,2 % copper) dual compartment
Approvals		ATEX II 2G EEx d IIC T6, explosion proof FM, explosion proof (Groups B, C and D) and non incensive CSA, explosion proof (Groups B, C and D) RosTechnadzor/GOST-R, Russian authorisation standards
SIL (Safety Integrity Level)		Functional safety to SIL1/SIL2 in accordance to IEC 61508 – SFF: 69 %. Full FMEDA report and declaration sheets available at request.
Net and gross weight		3,3 kg (7.3 lbs) net; 4,0 kg (8.8 lbs) gross (amplifier with 25 cm threaded probe)

PERFORMANCE

<i>Description</i>		<i>Specification</i>
Turn down ratio		100:1 typical (depending upon calibration)
Flow range	Max	0,13 - 200 Nm/s (25 - 40,000 SFPM) reference of air at STP conditions
	Min	0,13 - 2,5 Nm/s (25 - 500 SFPM) reference of air at STP conditions
Linearity		Included in flow accuracy
Accuracy	Flow	± 1 % of reading + 0,5 % of calibrated full scale
	Temperature	± 1 °C (2 °F)
Repeatability		± 0,5 % of reading
Response time		Time constant of 1 to 2 s
Remote electronics		Max 15 m (50') away from probe - for longer lengths, consult factory
Ambient temperature		-40 °C up to +70 °C (-40 °F up to +160 °F) – display not readable below -20 °C (-4 °F)
Operating temp. effect		± 0,04 % per °C
Humidity		99 %, non-condensing
Electromagnetic Compatibility		Meets CE requirements (EN-61000-6-4, EN 61000-6-2) and are in compliance with EMC directive 89/336/EEC

PROBE SPECIFICATIONS

<i>Description</i>	<i>Insertion probe</i>	<i>Sensor with flow body</i>
Materials – wetted parts	316/316L (1.4401/1.4404) or Hastelloy C (2.4819)	Sensor: 316/316L (1.4401/1.4404) Flow body: stainless steel or carbon steel
Mounting	Threaded, compression fitting, ANSI-DIN flanged or with Retractable probe assembly	Threaded or flanged
Probe length	From 70 mm up to 2530 mm (2.6" up to 100")	Flow body sizes from 1/2" up to 4"
Max. process temperature	Integral electronics: -45 °C up to +120 °C -45 °C up to +200 °C with 100 mm (4") longer probe serving as heat extension Remote electronics: -45 °C up to +200 °C	
Max pressure rating	103 bar (1500 psi) @ +20 °C (+70 °F) 95 bar (1375 psi) @ +200 °C (+400 °F) – direct insertion 75 bar (1100 psi) @ +200 °C (+400 °F) – with flow body	

DIMENSIONS IN mm (inches)

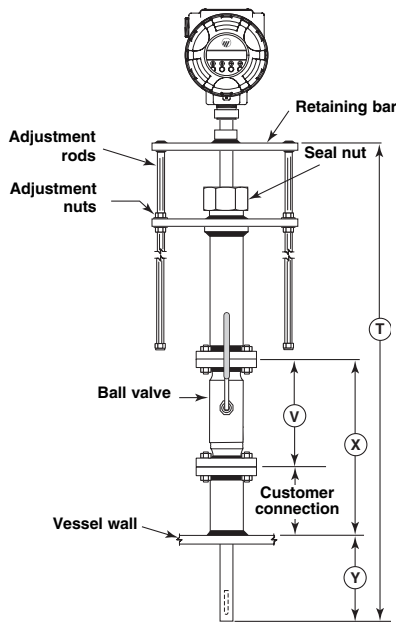

**Hot tap
Model RPA-FX12-XXX**

minimum probe length: $T = 2 (X + Y)$

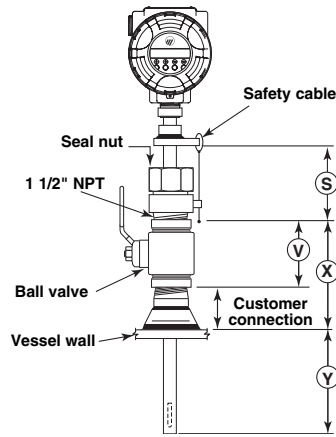

**Hot tap
Model RPA-E402-XXX**

minimum probe length: $S + X + Y$

S Dimension	
Threaded connection	102 (4.00)
Flanged connection	127 (5.00)

Ball Valve Dimensions*	
Size	V
1 1/2" NPT	112 (4.4)
1 1/2" 150# flange	165 (6.5)
1 1/2" 300# flange	190 (7.5)

*Dimension of ball valve if supplied by the factory.

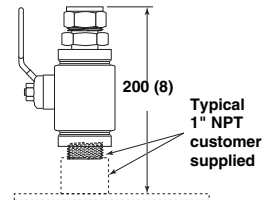

**1" NPT ball valve with
compression fitting (TFE ferrules)
(089-5218-001)**

Duct mounting bracket

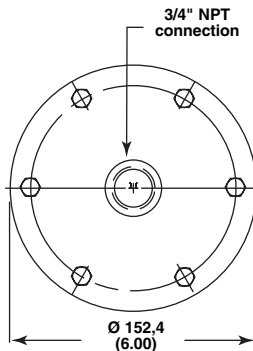

Duct mounting bracket with 3/4" NPT
part number 089-7247-001 or
089-7247-002 (includes hardware)

QUALITY ASSURANCE - ISO 9001:2000



THE QUALITY ASSURANCE SYSTEM IN PLACE AT MAGNETROL GUARANTEES THE HIGHEST LEVEL OF QUALITY DURING THE DESIGN, THE CONSTRUCTION AND THE SERVICE OF CONTROLS. OUR QUALITY ASSURANCE SYSTEM IS APPROVED AND CERTIFIED TO ISO 9001:2000 AND OUR TOTAL COMPANY IS COMMITTED TO PROVIDING FULL CUSTOMER SATISFACTION BOTH IN QUALITY PRODUCTS AND QUALITY SERVICE.

PRODUCT WARRANTY

ALL MAGNETROL ELECTRONIC AND ULTRASONIC LEVEL CONTROLS ARE WARRANTED FREE OF DEFECTS IN MATERIALS AND WORKMANSHIP FOR ONE FULL YEAR FROM THE DATE OF ORIGINAL FACTORY SHIPMENT. IF RETURNED WITHIN THE WARRANTY PERIOD; AND, UPON FACTORY INSPECTION OF THE CONTROL, THE CAUSE OF THE CLAIM IS DETERMINED TO BE COVERED UNDER THE WARRANTY; THEN, MAGNETROL INTERNATIONAL WILL REPAIR OR REPLACE THE CONTROL AT NO COST TO THE PURCHASER (OR OWNER) OTHER THAN TRANSPORTATION. MAGNETROL SHALL NOT BE LIABLE FOR MISAPPLICATION, LABOR CLAIMS, DIRECT OR CONSEQUENTIAL DAMAGE OR EXPENSE ARISING FROM THE INSTALLATION OR USE OF THE EQUIPMENT. THERE ARE NO OTHER WARRANTIES EXPRESSED OR IMPLIED, EXCEPT, SPECIAL WRITTEN WARRANTIES COVERING SOME MAGNETROL PRODUCTS.



BULLETIN N°: BE 54-130.6
EFFECTIVE: JULY 2006
SUPERSEDES: May 2006

UNDER RESERVE OF MODIFICATIONS

BENELUX	Heikensstraat 6, 9240 Zele, België Tel. +32 (0)52.45.11.11 • Fax. +32 (0)52.45.09.93 • E-Mail: info@magnetrol.be
DEUTSCHLAND	Alte Ziegelei 2-4, D-51491 Overath Tel. 02204 / 9536-0 • Fax. 02204 / 9536-53 • E-Mail: vertrieb@magnetrol.de
FRANCE	40 - 42, rue Gabriel Péri, 95130 Le Plessis Bouchard Tél. 01.34.44.26.10 • Fax. 01.34.44.26.06 • E-Mail: magnetrolfrance@magnetrol.fr
ITALIA	Via Aresè 12, I-20159 Milano Tel. (02) 607.22.98 (R.A.) • Fax. (02) 668.66.52 • E-Mail: mit.gen@magnetrol.it
UNITED KINGDOM	Unit 1 Regent Business Centre, Jubilee Road Burgess Hill West Sussex RH 15 9TL Tel. (01444) 871313 • Fax (01444) 871317 • E-Mail: sales@magnetrol.co.uk
INDIA	E-22, Anand Niketan, New Delhi - 110 021 Tel. 91 (11) 41661840 • Fax 91 (11) 41661843 • E-Mail: info@magnetrolindia.com

www.magnetrol.com

OUR NEAREST REPRESENTATIVE