

**Seismic
Sensors &
Systems**

PROTECTING
YOUR
INVESTMENT

SENSORS

SEISMIC

MONITORING & PROTECTION SYSTEMS

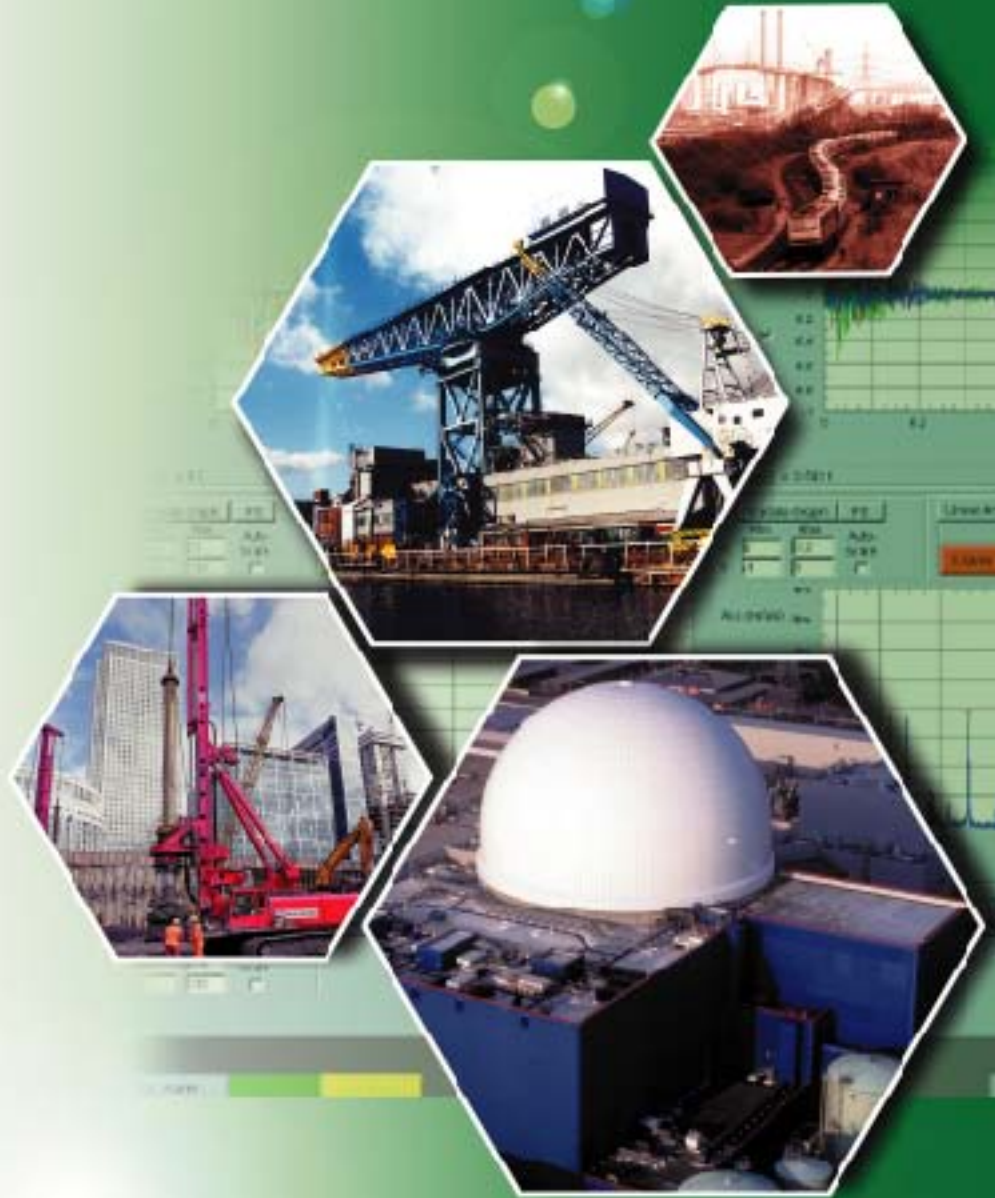

PRODUCT GUIDE

Seismic Transducers & Switches
Nuclear Infrastructure Protection
Structural & Environmental Monitoring
Data Capture & Analysis



PROTECTING INDUSTRY WORLDWIDE

For over twenty five years Sensonics instrumentation has been used throughout industry for the monitoring of both seismic and structural vibration events. We are the leading supplier of Seismic Monitoring and Protection systems to the UK Nuclear Industry. Whether the requirement is for a single transducer or a fully customised multi-location monitoring system, Sensonics can provide the solution.

The Sensonics range of industry proven high quality transducers, equipment and services include:-

- Wilmore MkIII Seismometer Range
- SP Series of Piezoelectric Transducers
- SA Series of Triaxial Seismic Protection Switches
- Multi-Channel Voting Rack Systems
- Event Recorder Equipment
- Alarm and Annunciator Rack Systems
- Replay and Analysis Software
- Customised Seismically Qualified Cubicle Equipment
- Turnkey System Design and Implementation
- Installation and Commissioning
- Maintenance and Support Services
- Calibration and Refurbishment

SP Series of Low Frequency Piezoelectric Seismic Transducers



The SP series of Piezoelectric Transducers are robust, portable, sealed instruments suitable for operation in any attitude without modification. The SP4 unique inertial system of matched piezoelectric elements arranged in a reciprocal configuration generates high output sensitivity and minimum noise with a capability for complete transducer verification through an input calibration facility.

Outputs proportional to ground acceleration or ground velocity are available with sensitivities of up to 50V/g. The sealed stainless steel casing makes the instruments particularly suited for field operation and with the optional waterproof connector, for underwater applications.

Available in single axis and three axis (X, Y & Z) configurations.

- Frequency Response down to 0.1Hz
- Acceleration Sensitivities up to 50V/g
- Velocity Sensitivities up to 2000V/m/s
- Dynamic Range >120dB
- Linearity better than 0.1%
- Hermetically Sealed
- Cross Axis Sensitivity <1%
- Voltage or Current Outputs
- -30°C to +140°C
- ATEX 'Intrinsically Safe' Versions



SA SERIES OF SEISMIC SAFETY SWITCHES

The SA series of seismic safety switches are fundamentally triaxial vibration detection devices, suitable for the protection of vulnerable structures from ground borne vibration events. The unit features three high sensitivity low noise seismometers in combination with high integrity alarm circuitry mounted in a robust weatherproof steel enclosure. The series are seismically qualified and feature an optional 2 out of 3 voting system.

When the vibration signal on any axis exceeds the set alarm threshold, the seismic alarm relays are activated, permitting further alarm processing for the safe shutdown of equipment. The switch can also be configured to provide a robust current loop output for each of the three axes of detection representing the measured seismic waveforms.

Utilising the SP4 seismic transducer permits full in-service testing and performance verification.



- Measurement Range 0.1Hz to 100Hz
- Actuating Sensitivity 0.005g to 0.5g
- Dynamic Range 90dB
- Sensors Triaxial SP4
- Power Supply 230Vac, 110Vac or 24Vdc
- Protection IP66, Optional Weather Shield Available
- Calibration Internal or External Oscillator, 20Vpk-pk, 1Hz Std
- Alarm Interface Seismic Event Relay, Transducer Integrity Relay Contact Rating 220V AC/DC at 2A
- Seismic Qualification IEEE Std 344-1987
- EMC Approval EN61326 (Heavy Industrial Standard) and Def Stan 59-41
- Applications Nuclear Power Plants, Oil Exploration & Mines, Large Structural Monitoring

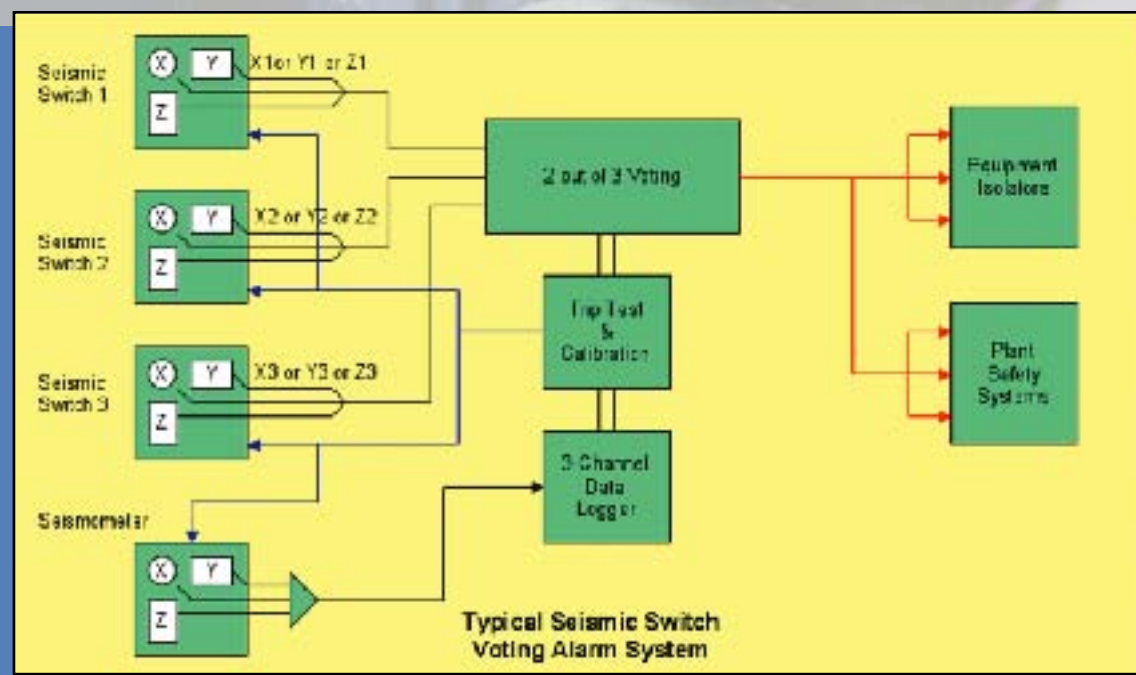

PROTECTING YOUR INVESTMENT

SEISMICS

NUCLEAR INFRASTRUCTURE PROTECTION



Sensonics are the leading supplier of Seismic Monitoring and Protection systems to the UK Nuclear Industry. We offer a range of equipment, which can be scaled to meet the most complex requirements. Integrity and robustness is key to our system concept, offering protected power supply configurations, custom indication panels, as well as alarm voting racks suitable for safety critical applications. The systems provide a secure and extremely dependable seismic alarm to the site operational staff, allowing rapid shutdown of plant processes in a controlled manner.

The key system components are as follows:-

- **Voting Rack** - Offering multi-channel 'two out of three' alarm voting. Utilising either robust electromechanical devices or triplicated programmable logic with self-fault diagnosis.
- **Recorder** – Robust PC with embedded operating system, contains on board non-volatile memory for program operation and event data storage.
- **Annunciator** – For local alarm indication and reset facilities. Key operated interlocks and alarm defeat facilities provide additional system robustness.
- **Calibrator** – Activates individual transducer self test facility for complete system integrity check.
- **UPS** – Typically configured in a dual redundant PSU configuration and available with various hold up times dependant on system load.
- **Qualifications** - Seismic qualification to IEEE Std 344-1987, EMC approval to Def Stan 59-41

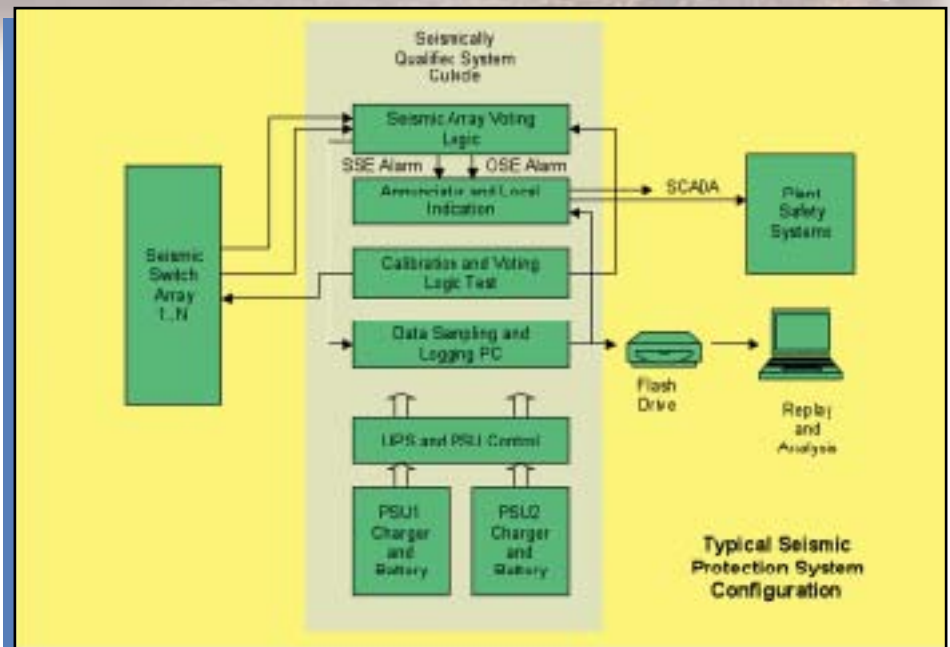

STRUCTURAL & ENVIRONMENTAL MONITORING

Through development of our established technologies proven in the nuclear industry, in combination with our sensor expertise, Sensonics can offer smart solutions for the vibration monitoring of civil structures. This includes facilities to meet the environmental standards required for both building and human vibration recording, to BS7385, BS6472 and DIN 4150.

Available with alarm voting for shutdown applications, the system offers maximum flexibility with remote access to view event data online and configure system parameters.

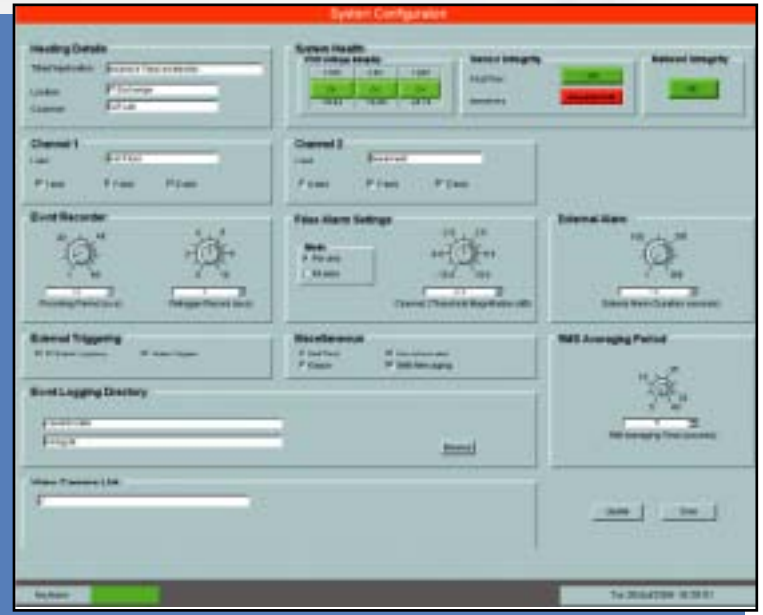

Facilities

- Acceleration and PPV Recording
- Alarm Voting with multiple trigger levels
- FTP Access to Event Files
- Summary Event Log
- Remote System Configuration
- Multiple SMS Messaging of event data
- Local Alarm Interface
- FFT and 3rd Octave analysis
- Video Capture on Alarm
- Self Test Facilities
- 0.1Hz to 300Hz Bandwidth
- 90dB Dynamic Range
- Rack Mount and UPS options available

Applications

- Construction Vibration Monitoring
- Bridges and Railway Infrastructure
- Large Civil Structures
- Earthquake Monitoring
- Tunnels
- Oil and Gas Pipelines
- Lifts

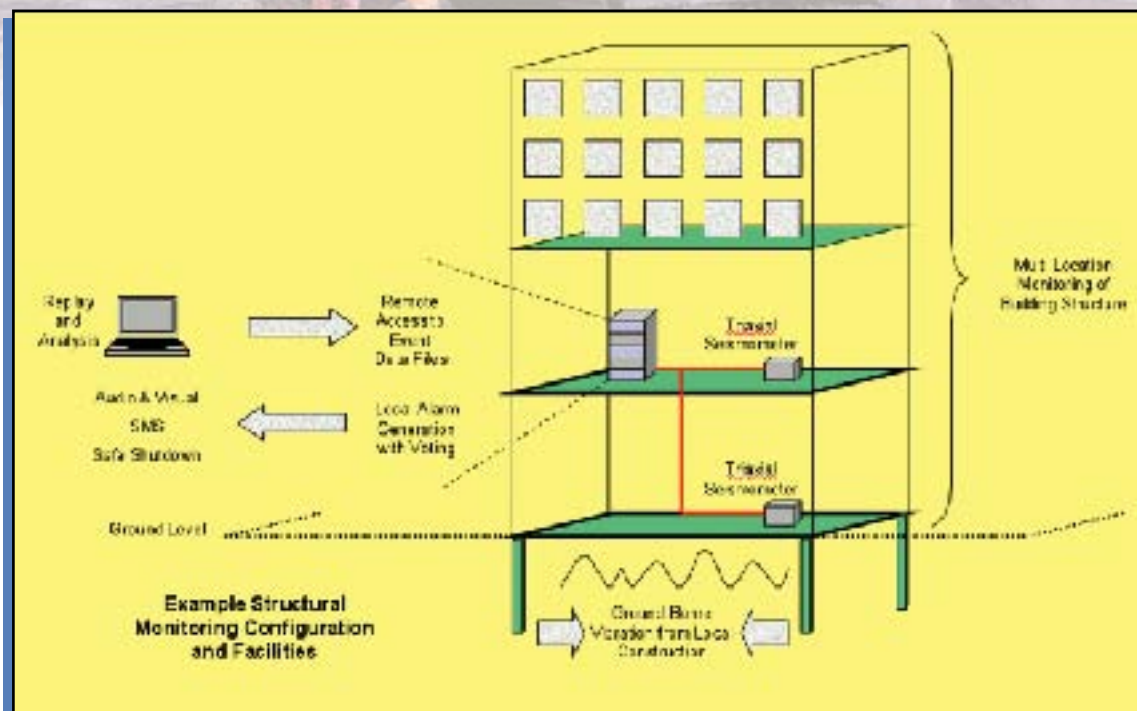

PROTECTING
YOUR
INVESTMENT

SENSONICS

DATA CAPTURE AND ANALYSIS

Sensonics can offer a number of software solutions for the capture and analysis of seismic event data, providing analysis in both the time and frequency domains. Embedded operating systems can be supplied to cater for the most severe applications, as well as protected processor and data storage configurations.

Inherent in our software systems are facilities to configure multiple alarm levels, setup alarm logic, adjust recording period (pre and post trigger), define alarm action and self-test. Customised software solutions to meet bespoke system requirements can be generated from our standard solutions.



The Complete Solution

From our offices in the UK, Sonsonics can offer 'through life' system support in addition to robust seismic system supply. This includes:-

- Data Collection and Analysis
- Installation and Commissioning
- Maintenance and Calibration
- Strategic Spares Holding
- Remote Support
- Customised Equipment Design
- 24 hour Support
- Contract Management



Contact our experienced project and engineering team to discuss your requirements.

GEOPHYSICAL PRODUCTS

The Willmore MkIII range of Seismometers are velocity sensing devices suitable for field, vault or observatory use. Available in both broadband and short period configurations, the MkIII sets a standard that is hard to beat.

The mass is a permanent magnet suspended on ligament springs, which achieves frictionless axial movement. The output is derived from two coils fixed to the frame, one at each end of the mass. Auxiliary coils are provided for feedback and calibration. The natural period of oscillation of the mass is adjustable so that the instrument can be optimally matched to the required operating conditions.

The broadband response is achieved by adding a low noise capacitive displacement transducing system to the basic MkIII suspension. A current proportional to the mass displacement is fed back to the 'moving coil' to maintain the mass at equilibrium. Adjustable electronic feedback damping is included to give the user, besides the noise reduction of the technique, an instrument capable of detecting earth motion from the micro-seismic to the strong motion range.



Willmore Mk III



Standard Output Responses Available:-

- Acceleration - DC to 25Hz, 10^4 V/m/s^2
- Broadband Velocity - 20s to 20Hz, 10^5 V/m/s^2
- Long Period Narrow Band - $2 \times 10^6 \text{ V/m/s}^2$ at 20s
- Short Period - $5 \times 10^6 \text{ V/m/s}^2$, 1s to 3s

Dynamic Range	140dB
Noise Level	10^{-9} m/s^2 per root Hz
Movement Range	+/- 2mm ultimate
Temperature Range	-40°C to 50°C
Sensitivity Variation Over Temperature	Less than 1%
Inertial Mass	1.2Kg
Housing	Polished Stainless Steel
Auxiliary Coils	10Kohm Primary, 500ohm Secondary

Mass can be clamped for transportation and position adjusted from outside of sealed case.



**PREDICTIVE
MAINTENANCE
SYSTEMS**

**KEEPING
INDUSTRY
TURNING**

SEISMIC PRODUCT RANGE

- Wilmore MkIII Seismometer Range
- SP Series of Piezoelectric Transducers
- SA Series of Triaxial Seismic Protection Switches
- Multi-Channel Voting Rack Systems
- Event Recorder Equipment
- Alarm and Annunciator Rack Units
- Replay and Analysis Software
- Customised Seismic Cubicle Design
- Turnkey System Design and Implementation
- Installation and Commissioning
- Maintenance and Support Services
- Calibration and Refurbishment

Due to Sensonics policy of constant improvement, designs may be subject to alteration without notice.

To order or request a sample or further information

Call Sensonics NOW on:

+44 (0) 1442 876833

or FAX us on: +44 (0) 1442 876477

or email on: sales@sensonics.co.uk

www.sensonics.co.uk

Also Available From Sensonics

- Eddy current probes
- LVDT's & RVDT's
- Other signal conditioning systems
- Accelerometers
- Portable vibration meters
- On line vibration monitoring

Sensonics Can Also Undertake

- Feasibility studies
- Installation and commissioning (turnkey projects)
- Condition monitoring surveys and contracts
- Diagnostic services
- System integration
- Product & application training



Sensonics Ltd, Northbridge Road, Berkhamsted, Hertfordshire HP4 1EF England
Telephone: +44 (0) 1442 876833 Facsimile: +44 (0) 1442 876477 email on: sales@sensonics.co.uk
www.sensonics.co.uk

If you are at all unsure about any application of the Sensonics products & systems please do not hesitate to call our technical sales department, who will be delighted to offer advice without obligation.