



Model R82 Pulse Burst Radar Level Transmitter

DESCRIPTION

The Model R82 is an economical, loop-powered radar transmitter bringing radar to everyday applications. Daily applications that have been considered for Ultrasonic can now use radar technology with its superior performance. The electronics are housed in a compact, single compartment cast aluminum or Lexan® housing. The R82 measures effectively even when atmospheres above the liquid are saturated with vapor. Pulse Burst technology and advanced signal processing manage common disturbances such as false echoes caused by obstructions, multi-path reflections from tank sidewalls or turbulence caused by agitators, aggressive chemicals, or aerators.

TECHNOLOGY

Model R82 Pulse Burst Radar emits short bursts of 26 GHz energy. High-speed timing circuitry measures the time of the signal reflected off the liquid surface. Sophisticated signal processing filters out false reflections and other background noises. The exact level is then calculated, by factoring tank height and sensor offset information. The Model R82 circuitry is extremely energy efficient so no duty cycling is needed like with likewise radars. This allows tracking of high rates of level change up to 180"/min (4.5m/min).

APPLICATIONS

MEDIA: Liquids and slurries; hydrocarbons to water based media (dielectric 1.7–100)

VESSELS: Most process or storage vessels up to rated temperature and pressure. Pits and sumps, metallic and non-metallic tanks, others including plastic, glass-lined and concrete.

CONDITIONS: Virtually all level measurement and control applications including process conditions exhibiting varying specific gravity and dielectric, visible vapors, high fill/empty rates and some turbulence.

MARKETS: All process markets including replacement of loop-powered, ultrasonic transmitters



FEATURES

- 26 GHz frequency
- 24 VDC, loop-power supply voltage
- Configure with 2-line × 16-character display, 4-push-button keypad and PACTware™ PC Program (see bulletin 59-101)
- Range (from threads) of 15" to 40 feet (0.4 to 12.2 m)
- Volume/Flow: 20-point strapping table
- Ambient: -40° to +175° F (-40° to +80° C)
- Process
 - Temperature: -40° to +200° F (-40° to +93° C)
 - Pressure: Vacuum to 200 psig (13.8 bar)
 - Dielectric: 1.7-100
- Performs to ±0.2" (5 mm) or 0.05% of tank height
- Lexan® EXL or Cast Aluminum housings
- Antenna horn encapsulated with Polypropylene, Tefzel® (optional)
- Antenna extensions of 2" (50 mm) and 8" (200 mm)
- 2" NPT or BSP; Tri-Clamp® and Varivent® (optional) connections
- Adjustable beam pattern without removing transmitter from vessel
- Antenna output of <.01 mW (avg), <2 mW (max)
- Safety Integrity Level (SIL) value of 1 (SFF 89.1%)

APPLICATIONS

PULSE BURST RADAR

STORAGE AND INTERMEDIATE HOLDING TANKS

CONDITIONS – Calm Surfaces

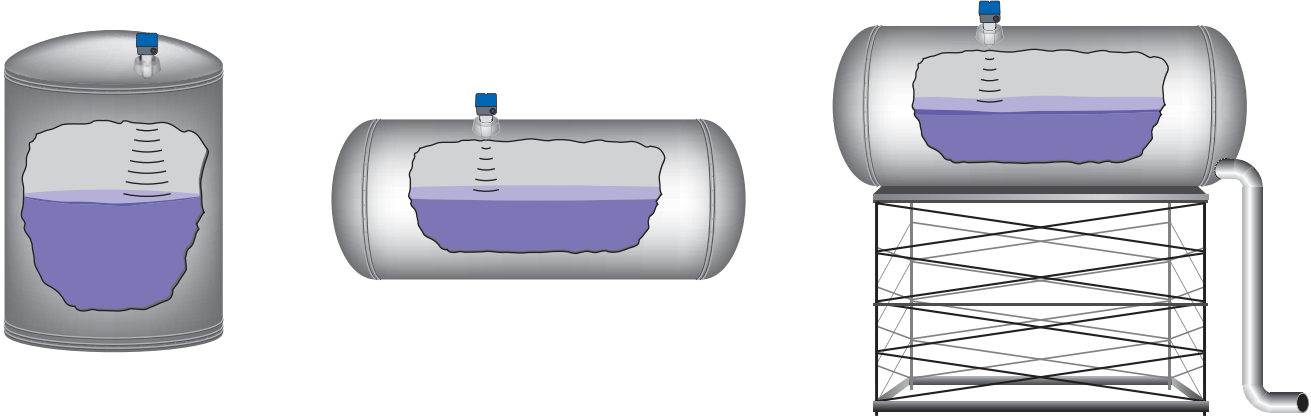

MIXING AND BLENDING VESSELS

CONDITIONS – Moderate Turbulence and Changing Dielectric

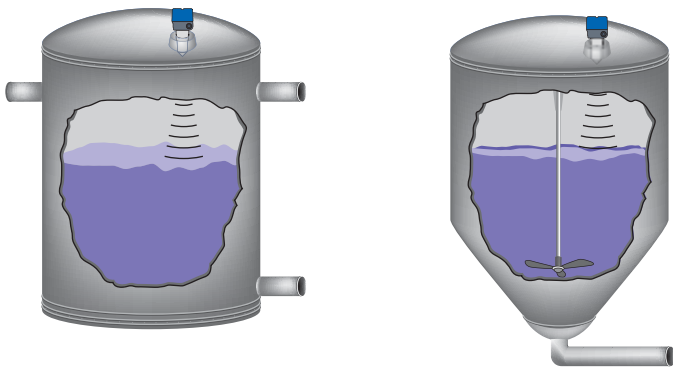

ENCLOSED SUMPS

CONDITIONS – Turbulence and Changing Dielectric

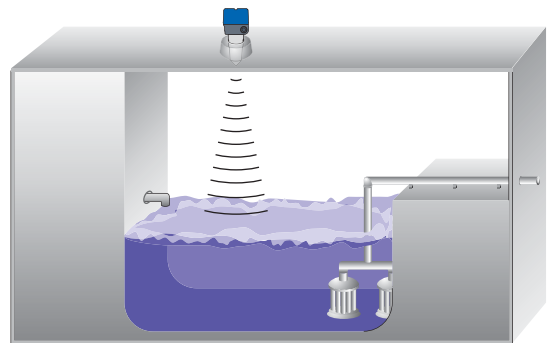

STANDPIPES AND CHAMBERS (2" ONLY)

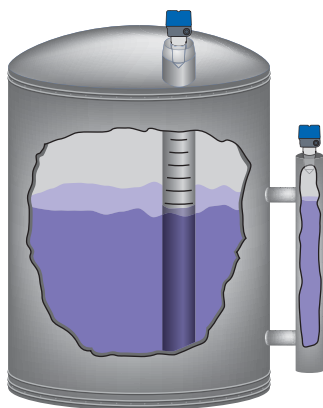

ENCLOSED FLUMES AND WEIRS

CONDITIONS – Turbulence and Changing Dielectric

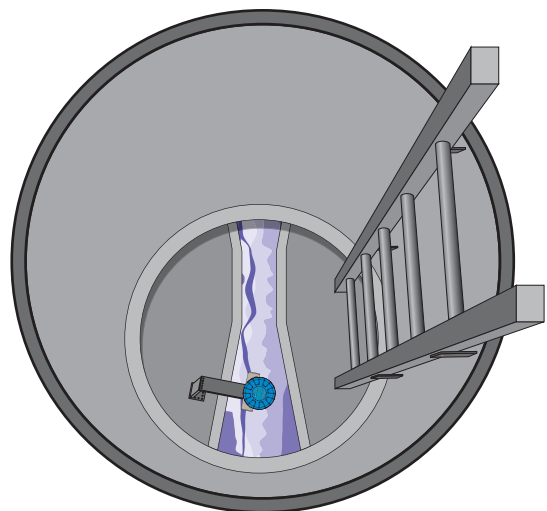

TECHNOLOGY

PULSE BURST RADAR

The R82 transmitter is a top-mounted, downward-looking pulse burst radar operating at 26 GHz America. Unlike true pulse devices (Eclipse Guided Wave Radar) which transmit a single, sharp (fast rise-time) waveform of wide-band energy (Figure 1), the R82 emits short bursts of 26 GHz energy (Figure 2) and measures the transit time of the signal reflected off the liquid surface.

Distance is calculated utilizing the equation Distance equals the Speed of light multiplied by the transit time divided by two ($Distance = C \times Transit\ Time / 2$), then developing the level value by factoring in tank height and sensor offset information (Figure 3). The exact reference point for distance and level calculations is the sensor reference point (bottom of an NPT thread, top of a BSP thread, or face of a flange).

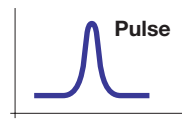

Figure 1

The exact level measurement is extracted from false target reflections and other background noise via the use of sophisticated signal processing. The R82 circuitry is extremely energy efficient so no duty cycling is necessary to accomplish effective measurement. For this reason it can track high rates of change (180 inches [450 cm] per minute) that have been impossible with existing loop-powered radar transmitters.

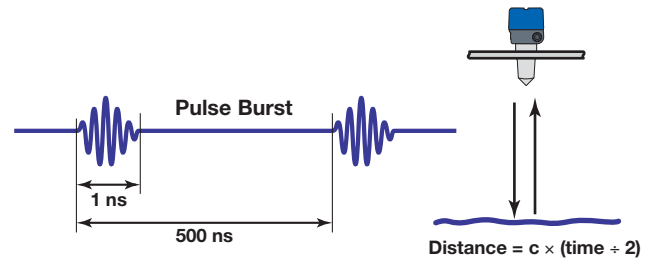

Figure 2

EQUIVALENT TIME SAMPLING

ETS, or Equivalent Time Sampling, is used to measure the high-speed, low power EM (electromagnetic) energy. ETS is a critical key in the application of radar to vessel level measurement technology. The high speed EM energy (~1 ft/nS) is difficult to measure over short distances and at the resolution required in the process industry. ETS captures the EM signals in real time (nanoseconds) and reconstructs them in equivalent time (milliseconds), which is much easier to measure with today's technology.

ETS is accomplished by scanning the vessel to collect thousands of samples. The round-trip event on a 40-foot (12.2 meter) tank takes only 82 nanoseconds in real time. After it is reconstructed in equivalent time it measures 135 milliseconds.

OPERATIONAL CONSIDERATIONS

Radar applications are characterized by three basic conditions:

- Dielectric
- Distance (measuring range)
- Disturbances (turbulence, foam, false targets, multiple reflections and rate of change)

The R82 Radar transmitter is offered with two basic antenna configurations:

- Polypropylene-encapsulated horn
- Tefzel®-encapsulated horn.

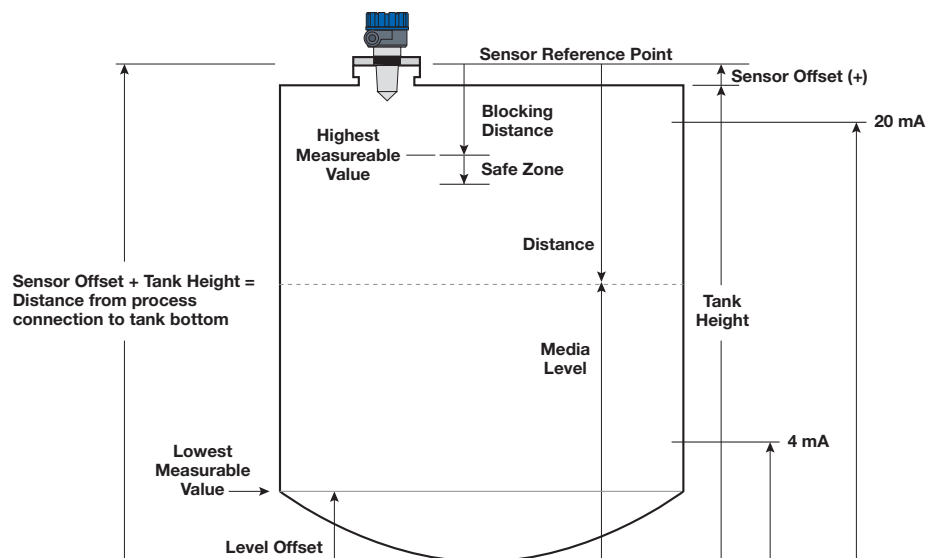

Figure 3

OPERATIONAL CONSIDERATIONS (cont.)

Maximum measuring range (distance) is calculated as Tank Height + Sensor Offset. Refer to Figure 3 on page 3. It is measured from the sensor reference point (bottom of NPT thread, top of BSP thread, or face of flange). The Maximum Distance chart shows the maximum measuring range of each antenna based on dielectric and turbulence.

MAXIMUM DISTANCE feet (meters)

Dielectric	Turbulence	R82
1.7-3.0	None	26 (8.0)
	Light, < 0.5"	21 (6.4)
	Moderate, < 1.0"	14 (4.3)
	Heavy, > 1.0"	7 (2.1)
3.0-10.0	None	33 (10.1)
	Light, < 0.5"	26 (7.9)
	Moderate, < 1.0"	19 (5.8)
	Heavy, > 1.0"	12 (3.7)
10.0-100	None	40 (12)
	Light, < 0.5"	32 (9.8)
	Moderate, < 1.0"	24 (7.3)
	Heavy, > 1.0"	17 (5.2)

MOUNTING

The R82 Radar transmitter can be mounted to a vessel using a variety of process connections. Generally either a threaded or flanged connection is used.

LOCATION

Ideally the radar transmitter should be mounted $\frac{1}{2}$ radius from center providing an unobstructed signal path to the liquid surface where it should illuminate (with microwave energy) the largest possible surface area. Do not install in center of tank top or within 10 inches (25 cm) of tank wall. Tank walls may produce reflections that must be minimized during field configuration (Orientation). Refer to Figure 4.

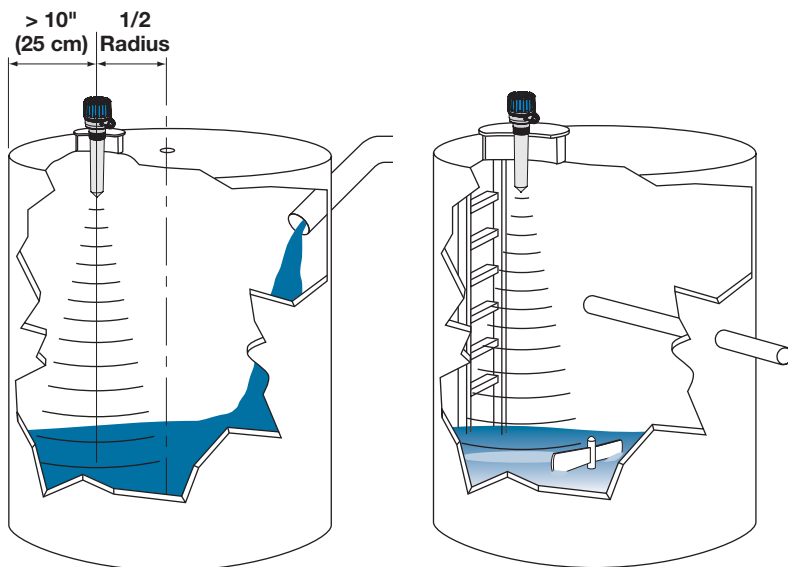

Figure 4

Figure 5

BEAM ANGLE

Figure 6 shows the beam angle for the R82 antennas. Ideally the beam pattern should illuminate the maximum liquid surface with a minimum of striking other objects in the vessel including the tank wall. Use these drawings to determine the optimum installation location.

OBSTRUCTIONS

Almost any object that falls within the beam pattern will cause reflections that may be misinterpreted as a false liquid level. Although the R82 has a powerful Echo Rejection routine, all possible precautions should be taken to minimize false target reflections with proper installation and orientation. Refer to Figures 5 & 6.

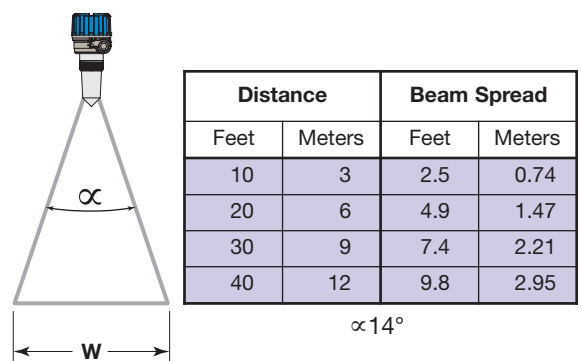

Figure 6

MOUNTING

NOZZLES

Improper installation in a nozzle creates “ringing” which will adversely affect measurement. Ideally, the antenna should be mounted so the end of the antenna is a minimum of 0.5" (12 mm) below the nozzle (be sure to include any nozzle dimension *inside* the vessel). Two Antenna extension lengths (2" or 8") are offered to allow the R82 transmitter to work reliably in a variety of nozzles.

The Minimum Blocking Distance of 15" (380 mm) is always measured from the bottom of the threads or face of a flange. The related distance (as measured from the end of the antenna) varies depending on the antenna extension chosen. Refer to Figure 7.

When necessary, the narrow beam width of the 26 GHz, R82 does allow mounting so that the antenna is recessed inside the nozzle. Optimally, the recessed dimension should never exceed 2x the nozzle diameter. Refer to Figure 8.

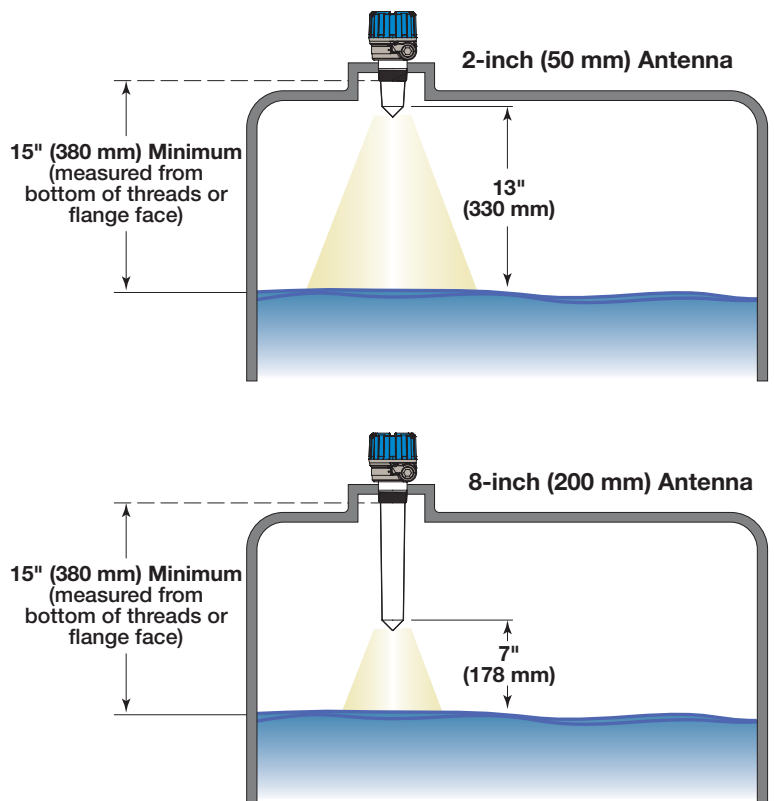

Figure 7
Minimum Blocking Distance

Maximum Recess (*m*) is $2 \times$ Nozzle Diameter (*d*)

example: 2" diameter nozzle

example: 4" diameter nozzle

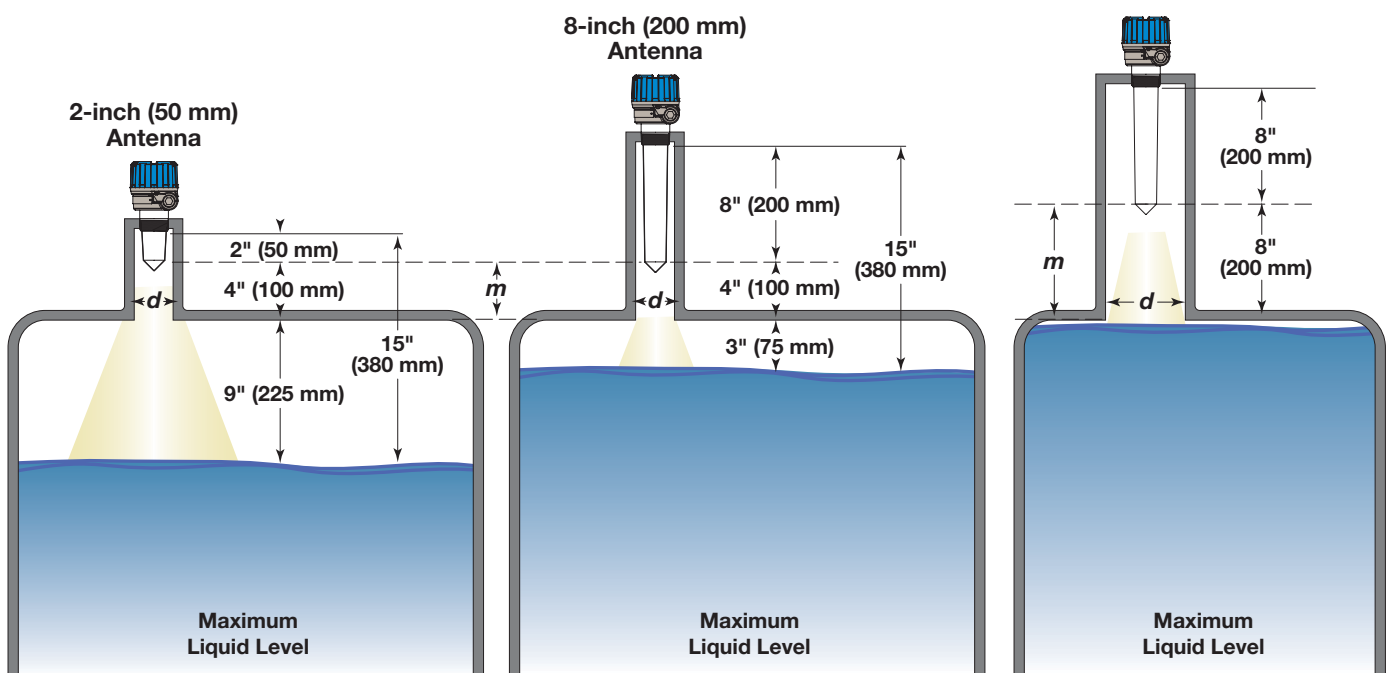

Figure 8
Maximizing Useable Capacity

ORIENTATION

The R82 transmitter utilizes a linearly polarized, microwave beam that can be rotated to improve its performance. Proper orientation can minimize unwanted target reflections, decrease sidewall reflections (multipath) and maximize direct reflections from the liquid surface. The Polarization pattern is parallel to the transmitter Display when the mechanism is at the #11 position. Refer to Figure 9.

In a typical vertical tank, the Launcher should be adjusted so the polarization pattern is parallel to a line tangent to the nearest tank wall. Refer to Figure 10.

For horizontal cylindrical vessels aim beam down the long axis of the vessel.

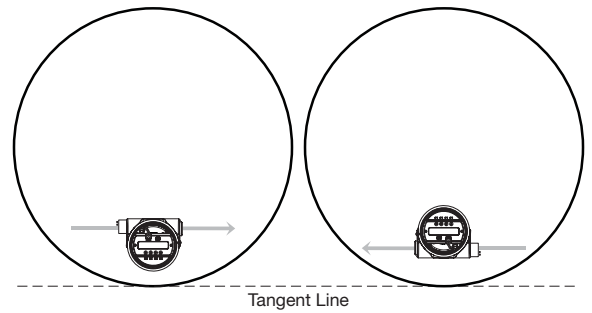

Figure 10
Launcher Orientation

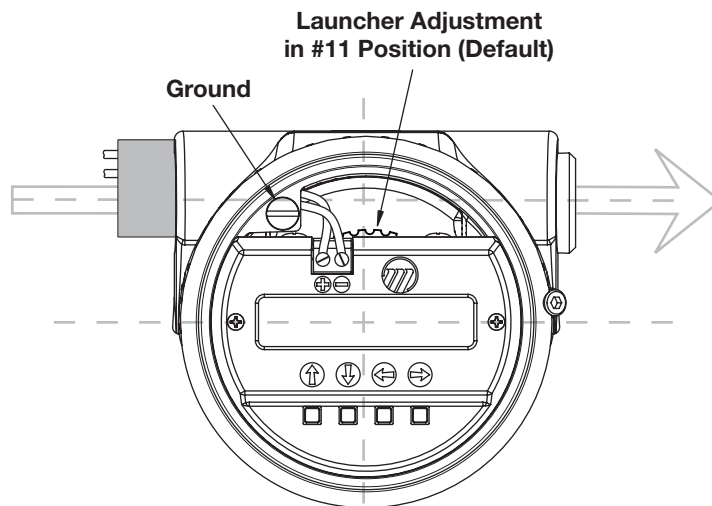

Figure 9
Internal Launcher Adjustment

STANDPIPES, STILLWELLS AND BRIDLES

The R82 can be mounted in a standpipe or stillwell but certain considerations should be given:

- Metal stillwells only: 2" (50 mm), Sched 40 maximum.
- Diameter must be consistent throughout length; no reducers.
- Stillwell length must cover complete range of measurement (i.e., liquid must be in stillwell).
- Welds should be smooth.
- Vents: holes <0.125" diameter, slots <0.125" width.
- If an isolation valve is used, it must be a full port ball valve with an I.D. equal to the pipe diameter.
- Bridles/Bypass Installations: The launcher adjustment (#9 position, default) should be rotated 90° from process connections.
- Configuration must include an entry for PIPE I.D.

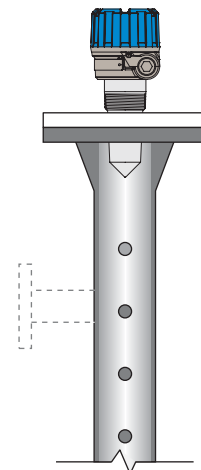

Figure 11
Use in Standpipe/Stillwell

PROBLEMATIC APPLICATIONS



GUIDED WAVE RADAR ALTERNATIVE

Some applications can be problematic for Pulse Burst Radar. The following are examples of when Guided Wave Radar is recommended.

- Extremely low dielectric media ($\epsilon_r < 2.0$).
- Very weak reflections from the liquid surface—particularly during turbulence can cause poor performance.
- Tanks heavily cluttered with false targets (mixers, pumps, ladders, pipes, etc.).
- During times of very low liquid levels of low dielectric media, the metal tank bottom may be detected (deteriorating performance).
- Foam can either absorb or reflect the microwave energy depending upon the depth, dielectric, density and wall thickness of the bubbles. Due to typical variations in the amount (depth) of foam, it is impossible to quantify performance. It may be possible to receive most, some or none of the transmitted energy.
- Extremely high liquid level (Overflow) conditions when liquid is very near the antenna can cause erroneous readings and measurement failure.

Refer to Eclipse Guided Wave Radar bulletin 57-101.

AGENCY APPROVALS

AGENCY	MODEL	PROTECTION METHOD	AREA CLASSIFICATION
 APPROVED	United States R82-52XA-0XX	Intrinsically Safe	Class I, Div. 1; Groups A, B, C, & D T4 @80°C; NEMA 4X, IP 66 ① Entity
	R82-51XA-0XX	Non-Incendive ②	Class I, Div. 2; Groups A, B, C, & D NEMA 4X, IP 66 ①
 APPROVED	Canada R82-52XA-0XX	Intrinsically Safe	Class I, Div. 1; Groups A, B, C, & D T4 @80°C; Type 4X, IP 66 ① Entity
	R82-51XA-0XX	Non-Incendive ②	Class I, Div. 2; Groups A, B, C, & D T4 @80°C; Type 4X, IP 66 ①
ATEX 	R82-5BXA-0XX	Intrinsically Safe ③④ EN60079-0: 2007 EN60079-11: 2007 EN60079-26: 2007 standards applied	ATEX II 1G Ex ia II T4 @70°C Ambient Temp: -40° to +70° C

- ① NEMA rating applies to aluminum housing with Tefzel antenna only.
- ② For Division 2 the measured media inside the vessel must be non-flammable only and the apparatus must be only connected to an inherently limited power source (Class 2 power supply) as defined in the NEC table 11.

Special conditions for safe use (ATEX Ex i)

- ③ Materials marked as category 1 equipment and mounted in hazardous areas requiring this category shall be installed in such a way that, even in the event of rare incidents, the aluminum enclosure cannot be an ignition source due to impact or friction.
- ④ The transmitter shall be installed so that electrostatic discharges on plastic parts are prevented.



These units have been tested to EN61326 and are in compliance with the EMC Directive 2004/106/EC EN302 372-1 and EN301 489-1 & -3 and are in compliance with the RTTE.

ATEX Entity Parameters

Vi	28.4 VDC	28 VDC
Ii	94 mA	120 mA
Pi	0.67 w	0.84 w
Ci	5.5 nF	
Li	370 μH	

SIL

	Model R82	
SIL	1 as 1001	
Instrument Type	B	
SFF	89.1%	
PFDavg	3.34E-04	
	FITS	Annual
Fail Dangerous Undetected	68	5.96E-04
Fail Dangerous Detected	388	3.40E-03
Safe	169	1.48E-03

COMMUNICATIONS APPROVALS

Region	Agency	Frequency
US	FCC	26 GHz
Canada	IC	
Europe	RTTE	

SPECIFICATIONS

TRANSMITTER: FUNCTIONAL

System Design	
Measurement Principle	Pulse burst radar @ 26 GHz ①
Input	
Measured Variable	Level, determined by the time-of-flight of a radar pulse from transmitter to product surface and back
Span	15" to 40 feet (380 mm to 12.2 m) measured from threads
Output	
Type	Analog: 4 to 20 mA with optional HART digital signal
Range	Analog: 3.8 to 20.5 mA useable (Namur NE43)
	Digital: 0 to 999" (0 to 9999 cm)
Resolution	Analog: 0.01 mA
	Digital: 0.1"
Loop Resistance	GP/IS/XP - 400 Ω @ 24 VDC/20 mA, 350 Ω @ 24 VDC/22 mA
Diagnostic Alarm	Adjustable 3.6 mA, 22 mA, HOLD
Damping	Adjustable 0-45
Output at Antenna	< .01 mW (avg), < 2 mW (max)
User Interface	
Keypad	4-button menu-driven data entry and system security
Indication	2-line × 16-character display
Digital Communication ①	HART Version 5 compatible
Power (Measured at instrument terminals)	
General Purpose/Intrinsically Safe	16 to 36 VDC
Housing	
Material	Lexan® base and cover Cast Aluminum A356T6 (<0.2% copper)
Cable Entry	¾" NPT, M20
Ingress Protection	Lexan Housing: NEMA 6P (IP67/68) ②
	Aluminum Housing: NEMA 4X/6P (IP67/68) ②
Net/Gross Weight	Short Lexan: 23 oz.
	Long Lexan: 32 oz.
	Short Aluminum: 49 oz.
	Long Aluminum: 58 oz.
Overall Dimensions	Lexan: Refer to drawings on page 11
	Aluminum: Refer to drawings on page 11

① RTTE: European approval,
FCC & IC: North American approval

② Installation for NEMA 6P/IP 68:
the transmitter can be installed to
allow for temporary submergence
to 6.5 ft. (2 m) for 24 hours.

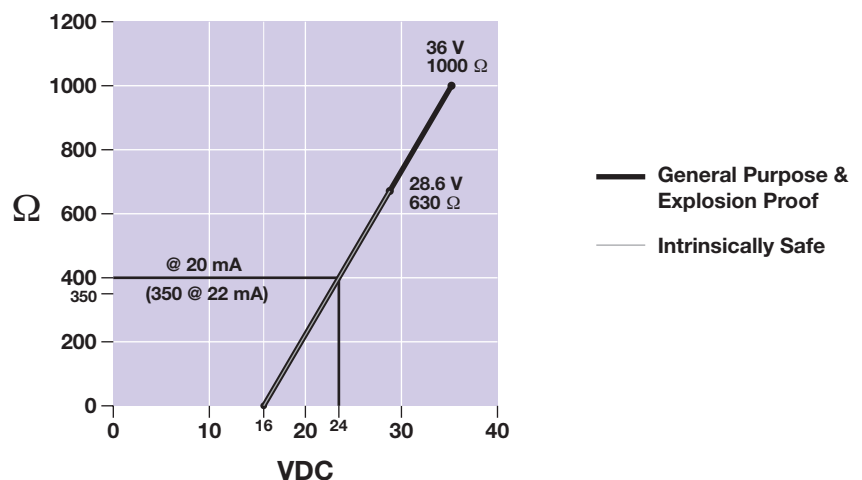

SPECIFICATIONS

TRANSMITTER: FUNCTIONAL (CONT.)

Antenna	
Encapsulated Horn	Polypropylene, Tefzel® (optional)
	-40° to +200° F @atmos (-40° to +93° C)
	Vacuum to 200 psig @ +70° F (-1 to 13.8 bar) Tefzel
Wetted Surfaces	Polypropylene or Tefzel (optional)
Environment	
Operating Temperature	-40° to +175° F (-40° to +80° C)
LCD	-5° to +160° F (-20° to +70° C)
Storage Temperature	-50° to +175° F (-46° to +80° C)
Humidity	0-99%, non-condensing
Electromagnetic	Meets CE Requirements: EN 50081-2, EN 50082-2
Surge Protection	Meets CE Requirements: EN 61326 (1000 volts)
Shock Class	ANSI/ISA-S71.03 Class SA1
Vibration Class	ANSI/ISA-S71.03 Class VC2

TRANSMITTER: PERFORMANCE

Reference Conditions	Reflection from ideal reflector at +70° F (+20° C)
Linearity	±0.2 inch (5 mm) or 0.05% of tank height (whichever is greater)
Measured Error	±0.2 inch (5 mm) or 0.05% of tank height (whichever is greater) (Performance will degrade slightly within 60" (1.5 m) of antenna)
Resolution	0.1 inch (2.5 mm)
Repeatability	< 0.1 inch (2.5 mm) or 0.025% of tank height
Response Time	< 1 second
Warm-up Time	30 seconds
Ambient Temp. Effect	0.05% per 10° C
Process Dielectric Effect	< 0.3 inch within selected range
Maximum Rate of Change	180 inches (450 cm)/minute
Minimum Dielectric:	1.7

ANTENNA: FUNCTIONAL

Encapsulated Horn Antenna	Polypropylene	Tefzel®
Process Connection	2" NPT/BSP sanitary flanges	
Maximum Process Temperature	-40° to +200° F @ atmos (-40° to +93° C @ atmos)	
Maximum Process Pressure	Vacuum to 200 psig @ +70° F (-1 to 13.8 bar @ +20° C)	
Minimum Dielectric (application dependent)	1.7	

ANTENNA: RATINGS PRESSURE / TEMPERATURE ①

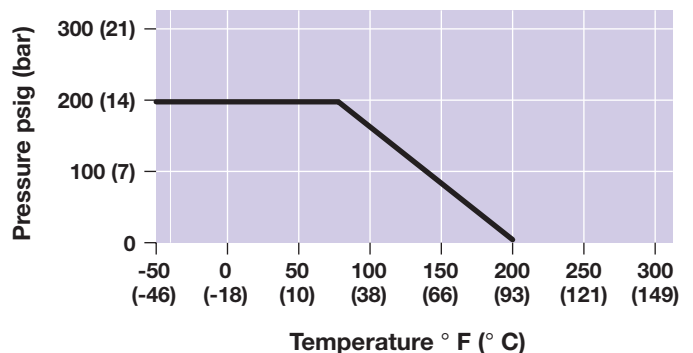

① Maximum Pressure ratings for CRN are derated to 130 psig (-1 to +9 bar) @ +70° F (+20° C)

MODEL NUMBER



Models available for quick shipment, usually within one week after factory receipt of a purchase order, through the Expedite Ship Plan (ESP).

BASIC MODEL NUMBER

R	RADAR Level Transmitter
---	-------------------------

OPERATING FREQUENCY

8	26 GHz
---	--------

TRANSMITTER MODEL

2	Economical
---	------------

POWER/SIGNAL

5	24 VDC, Two-Wire; 4-20 mA with HART
---	-------------------------------------

AGENCY CLASSIFICATION

1	Integral, General Purpose/Non-Incendive (cFMus)
2	Integral, Intrinsically Safe (cFMus)
A	Integral, General Purpose
B	Integral, Intrinsically Safe (ATEX II 1G Ex ia IIC T4 @70°C)

HOUSING/CONDUIT CONNECTION

0	Cast Aluminum, Single Compartment; 3/4" NPT
1	Cast Aluminum, Single Compartment; M20
6	Lexan® Plastic, Single Compartment, 3/4" NPT
7	Lexan Plastic, Single Compartment, M20

ACCESSORIES

A	Digital Display and Keypad
---	----------------------------

ANTENNA TYPE

1	Polypropylene, 2" (50 mm) Extension
2	Polypropylene, 8" (200 mm) Extension
3	Tefzel®, 2" (50 mm) Extension
4	Tefzel, 8" (200 mm) Extension

PROCESS CONNECTION

1	2" NPT
2	2" BSP
A	2½" Tri-Clover®
B	3" Tri-Clover
D	80 mm Tuchenhagen

Note: Options A, B and D are available with ANTENNA TYPE 3 or 4 (Tefzel) only.

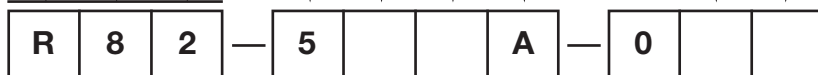

THREAD-ON FLANGE PART NUMBERS

FOR USE WITH 2" NPT CONNECTIONS

CARBON STEEL		
2"	150#	004-6820-013
3"		004-6820-001
4"		004-6820-007
6"		004-6820-016
3"	300#	004-6820-002
4"		004-6820-008
3"	600#	004-6820-003
4"		004-6820-009

304 SS		
2"		004-6820-019
3"		004-6820-020
4"		004-6820-021
6"		004-6820-022
316 SS / 316L SS		
2"	150#	004-6820-023
3"		004-6820-024
4"		004-6820-025
6"		004-6820-026
3"	300#	004-6820-005
4"		004-6820-011
3"	600#	004-6820-006
4"		004-6820-012

FIBERGLASS	
2"	004-6823-018
3"	004-6823-019
4"	004-6823-020
KYNAR	
2"	004-6823-028
3"	004-6823-029
4"	004-6823-030
PVC	
2"	004-6823-008
3"	004-6823-009
4"	004-6823-010

DIMENSIONAL SPECIFICATIONS

INCHES (MM)

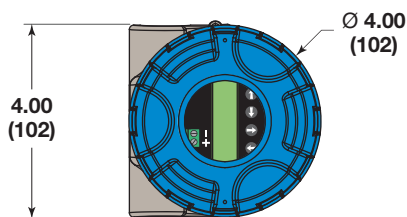

Aluminum Housing
Top View

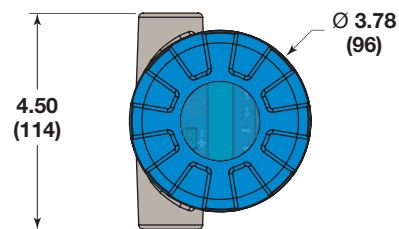

Lexan® Housing
Top View

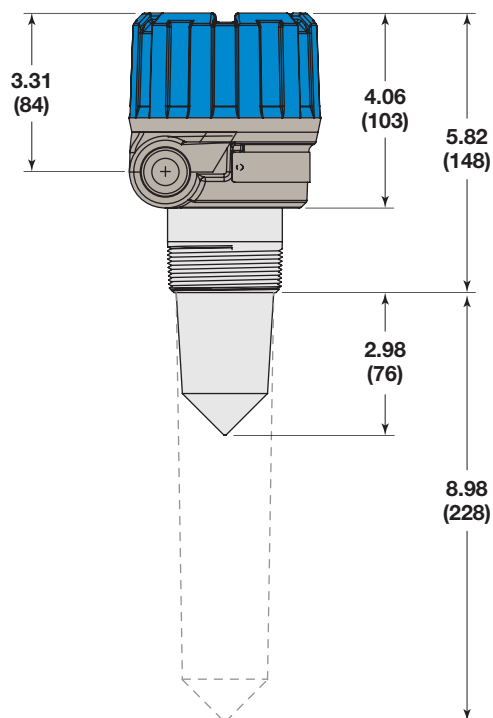

Aluminum Housing
Side View

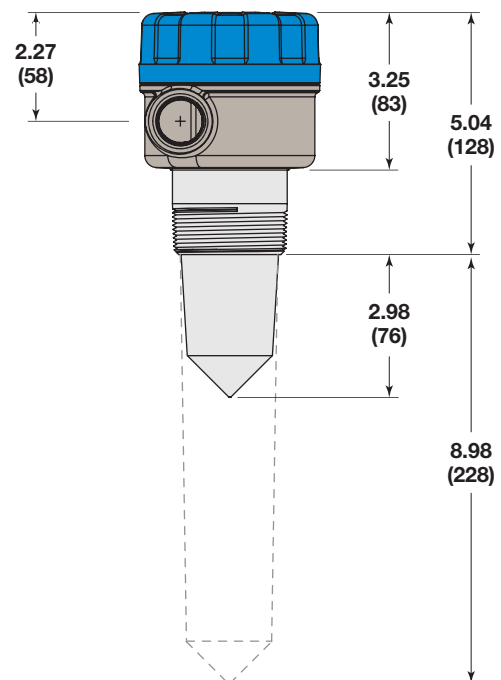

Lexan® Housing
Side View

QUALITY



The quality assurance system in place at Magnetrol guarantees the highest level of quality throughout the company. Magnetrol is committed to providing full customer satisfaction both in quality products and quality service.

Magnetrol's quality assurance system is registered to ISO 9001 affirming its commitment to known international quality standards providing the strongest assurance of product/service quality available.

ESP

Expedite Ship Plan

Several R82 Through-Air Radar Level Transmitters are available for quick shipment, usually within one week after factory receipt of a purchase order, through the Expedite Ship Plan (ESP).

Models covered by ESP service are color coded in the selection data charts.

To take advantage of ESP, simply match the color coded model number codes (standard dimensions apply).

ESP service may not apply to orders of ten units or more. Contact your local representative for lead times on larger volume orders, as well as other products and options.

WARRANTY



All Magnetrol electronic level and flow controls are warranted free of defects in materials or workmanship for one full year from the date of original factory shipment.

If returned within the warranty period; and, upon factory inspection of the control, the cause of the claim is determined to be covered under the warranty; then, Magnetrol will repair or replace the control at no cost

to the purchaser (or owner) other than transportation.

Magnetrol shall not be liable for misapplication, labor claims, direct or consequential damage or expense arising from the installation or use of equipment. There are no other warranties expressed or implied, except special written warranties covering some Magnetrol products.

For additional information, see Instruction Manual 58-610.



5300 Belmont Road • Downers Grove, Illinois 60515-4499 • 630-969-4000 • Fax 630-969-9489 • www.magnetrol.com
145 Jardin Drive, Units 1 & 2 • Concord, Ontario Canada L4K 1X7 • 905-738-9600 • Fax 905-738-1306
Heikensstraat 6 • B 9240 Zele, Belgium • 052 45.11.11 • Fax 052 45.09.93
Regent Business Ctr., Jubilee Rd. • Burgess Hill, Sussex RH15 9TL U.K. • 01444-871313 • Fax 01444-871317

Copyright © 2009 Magnetrol International, Incorporated. All rights reserved. Printed in the USA.
Performance specifications are effective with date of issue and are subject to change without notice.

Magnetrol & Magnetrol logotype and Eclipse are registered trademarks of Magnetrol International
HART is a registered trademark of the HART Communication Foundation
PACTware is trademark of PACTware Consortium
CSA logotype is a registered trademark of Canadian Standards Association
Tri-Clover is a registered trademark of Tri-Clover, Inc.
Tefzel is a registered trademark of Du Pont de Nemours and Company
Lexan is a registered trademark of General Electric
Varivent is a registered trademark of Tuchenhagen GmbH LTD

BULLETIN: 58-110.0
EFFECTIVE: July 2009