

Mark 608IS Series

Gas Pressure Regulators

3/4" – 1-1/4"

The Mark 608IS gas pressure regulator is the ideal valve for low pressure gas regulation. The self-contained low pressure gas regulator is for use on tank blanketing, gas meter inlet pressure regulating, gas burners and other low pressure air and gas applications.

The Mark 608 is normally open. Increases in the outlet pressure are sensed through the aspirator causing the large elastomer diaphragm to rise, which moves the plug toward the seat. As outlet pressure decreases, the diaphragm moves down and moves the plug away from the seat to increase flow. The lever, which connects the stem to the diaphragm, amplifies diaphragm forces for tighter shutoff.

FEATURES

- Inlet pressures up to 150 psi (10 bar)
- Rugged, heavy-duty design – emergency outlet pressure may reach 100% on inlet pressure without damaging valve
- 360° body orientation – valve can be installed in any position and can be easily repositioned while in-line
- Easy maintenance – seat and plug can be inspected without removing body from the line
- Completely self-operated – no external power source required
- Tight shutoff – soft elastomer plug provides ANSI Class VI shutoff

SPECIFICATIONS

Sizes: 3/4" (DN20), 1" (DN25), 1-1/4" (DN32)

End Connections

- Threaded – NPT, SWE, BSPT, BSPP
- Flanged – 150#, 300#, PN16, PN40

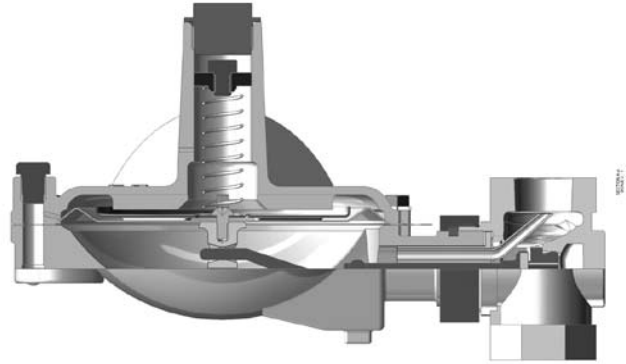

Materials

- Body: Ductile Iron, Carbon Steel (A216, WCB), Stainless Steel (A351/CF8M)
- Seat: Stainless Steel (CS/SS/DI body)
- Plug: Stainless Steel and Buna-N (DI body); Stainless Steel and Viton (CS & SS body)
- Diaphragm: Buna-N/Nylon (DI body); Viton (CS & SS body)
- Aspirator Tube: Delrin/SST; optional PTFE/SST
- Actuator Cases: CS for CS; CI for DI; SST for SST
- Others upon request

Service: air or gas

Shutoff: ANSI Class VI

Temperature Range: -20°F (-29°C) to 200°F (93°C)

Maximum Inlet Pressure: 150 psi (10 bar)

Reduced Pressure Control Range

- 1.0 to 2.5 inches w.c. (2,5 to 6,2 mbar)
- 2.0 to 5.5 inches w.c. (5,0 to 13,7 mbar)
- 4.0 to 10.0 inches w.c. (10,0 to 24,9 mbar)
- 5.0 to 30.0 inches w.c. (12,4 to 74,7 mbar)
- 0.5 to 1.75 psig (0,03 to 0,12 mbar)
- 1.0 to 3.5 psig (0,07 to 0,24 mbar)

Orifice Sizes (interchangeable): 1/8" (3mm), 3/16" (5mm), 1/4" (6mm), 5/16" (8mm), 3/8" (10mm), 7/16" (11mm), 1/2" (13mm), 9/16" (14mm)



Jordan Valve a division of Richards Industries

3170 Wasson Road • Cincinnati, OH 45209
513.533.5600 • 800.543.7311 • 513.871.0105 (f)
info@richardsind.com • www.jordanvalve.com

MARK 608IS SERIES GAS PRESSURE REGULATORS

FLOW CHARTS

- 3/4" MK608IS Capacities (scfh) – with Aspirator

Set Pressure	Inlet (psi)	Orifice Size							
		1/8"	3/16"	1/4"	5/16"	3/8"	7/16"	1/2"	9/16"
2" H2O (1-2.5" H2O) 1" H2O Droop 2" H2O Boost	5	201	374	430	261	477	888	1043	1169
	10	213	402	456	580	506	784	943	
	20	222	392	475	619	361			
	40	299	465	639	764				
	60	665	897	1161					
	80	816	873	1139					
	100	598	640						
	150	770	825						
3" H2O (2-5" H2O) 1" H2O Droop 2" H2O Boost	5	239	373	503	560	613	886	1163	1195
	10	231	402	566	580	591	783	977	
	20	211	392	570	619	295			
	40	277	465	649	764				
	60	597	897	1194					
	80	753	873	976					
	100	675	776						
	150	880	825						
7" H2O (4-10" H2O) 1" H2O Droop 2" H2O Boost	5	220	295	372	409	441	619	799	661
	10	277	427	578	527	476	732	982	
	20	258	462	661	893	1118	1154		
	35	276	592	897	967	1035	1294		
	75	525	980	1426					
	90	727	1364						
	100	813	1503						
	150	1040	1926						
28" H2O (5-30" H2O) 5-1/2" H2O Droop	5	302	454	604	722	839	941	1040	1074
	10	337	533	723	981	1239	1378	1514	
	30	283	816	1335	1666	1982	2154		
	45	617	1373	2058	2487				
	60	817	1866	2906	2899				
	75	820	1812						
	100	840	1867						
	150	1089	2421						
1.25 psi (0.5 - 1.75 psi) 0.2 psi Droop	5	180	272	439	395	526	465	658	921
	10	235	333	522	535	783	665	913	848
	30	279	469	824	785	1014	1141		
	45	354	561	886	856	1033			
	60	418	669	1003	937	1087			
	75	427	762	1152					
	100	543	949	1402					
	150	715	1266	1816					
3 psi (1 - 3.5 psi) 0.3 psi Droop	5	145	217	289	315	338	371	402	675
	10	209	312	418	502	592	625	661	731
	30	226	468	701	783	859	1136		
	45	354	561	812	856	856			
	60	415	669	922	937	945			
	75	427	762	1059					
	100	503	949	1408					
	150	660	1266	1816					

MARK 608IS SERIES GAS PRESSURE REGULATORS

FLOW CHARTS

- 1" MK608IS Capacities (scfh) – with Aspirator

Set Pressure	Inlet (psi)	Orifice Size							
		1/8"	3/16"	1/4"	5/16"	3/8"	7/16"	1/2"	9/16"
2" H2O (1-2.5" H2O) 1" H2O Droop 2" H2O Boost	5	226	420	483	630	536	998	1172	1313
	10	328	618	702	893	779	1206	1450	
	20	493	872	1055	1376	803			
	40	786	1224	1681	2010				
	60	1073	1447	1872					
	80	1360	1455	1898					
	100	1648	1763						
	150	2146	2256						
3" H2O (2-5" H2O) 1" H2O Droop 2" H2O Boost	5	268	419	565	629	689	996	1307	1342
	10	356	618	870	892	910	1205	1503	
	20	469	872	1266	1376	656			
	40	730	1224	1707	2010				
	60	963	1447	1926					
	80	1255	1455	1627					
	100	1534	1763						
	150	1981	2256						
7" H2O (4-10" H2O) 1" H2O Droop 2" H2O Boost	5	283	378	477	524	565	793	1024	848
	10	380	585	791	722	653	1003	1345	
	20	488	871	1247	1684	2110	2177		
	35	673	1444	2188	2358	2525	3155		
	75	1221	2278	3317					
	90	1399	2623						
	100	1534	2836						
	150	1981	3687						
28" H2O (5-30" H2O) 5-1/2" H2O Droop	5	318	478	636	760	883	991	1095	1130
	10	388	613	831	1128	1424	1584	1741	
	30	373	1074	1756	2192	2608	2834		
	45	718	1596	2393	2892				
	60	929	2121	3302	3294				
	75	1139	2517						
	100	1449	3219						
	150	1871	4182						
1.25 psi (0.5 - 1.75 psi) 0.2 psi Droop	5	198	299	482	434	578	511	723	1012
	10	267	378	593	608	890	756	1038	964
	30	328	552	969	924	1193	1342		
	45	479	758	1197	1157	1396			
	60	624	998	1497	1398	1622			
	75	689	1229	1858					
	100	920	1609	2376					
	150	1211	2091	3081					
3 psi (1 - 3.5 psi) 0.3 psi Droop	5	159	238	318	346	371	408	442	742
	10	237	355	475	571	672	710	752	831
	30	266	550	825	921	1011	1337		
	45	479	758	1097	1157	1157			
	60	619	998	1376	1398	1410			
	75	689	1229	1708					
	100	852	1609	2387					
	150	1100	2091	3081					

MARK 608IS SERIES GAS PRESSURE REGULATORS

FLOW CHARTS

- 1-1/4" MK608IS Capacities (scfh) – with Aspirator

Set Pressure	Inlet (psi)	Orifice Size							
		1/8"	3/16"	1/4"	5/16"	3/8"	7/16"	1/2"	9/16"
2" H2O (1-2.5" H2O) 1" H2O Droop 2" H2O Boost	5	283	525	604	788	670	1248	1465	1641
	10	420	791	899	1143	997	1544	1856	
	20	838	1482	1794	2339	1365			
	40	1234	1922	2639	3156				
	60	1610	2171	2808					
	80	1904	2037	2567					
	100	2225	2380						
	150	2861	3081						
3" H2O (2-5" H2O) 1" H2O Droop 2" H2O Boost	5	336	524	707	786	861	1245	1634	1678
	10	456	791	1114	1142	1165	1542	1924	
	20	797	1482	2152	2339	1116			
	40	1146	1922	2680	3156				
	60	1445	2171	2889					
	80	1757	2037	2277					
	100	2071	2380						
	150	2861	3081						
7" H2O (4-10" H2O) 1" H2O Droop 2" H2O Boost	5	407	544	687	755	814	1142	1475	1221
	10	459	708	957	874	790	1214	1627	
	20	575	1028	1472	1987	2490	2569		
	35	1077	2310	3501	3773	4040	5048		
	75	1917	3576	5207					
	90	2099	3935						
	100	1918	3545						
	150	2476	4622						
28" H2O (5-30" H2O) 5-1/2" H2O Droop	5	404	607	808	965	1122	1259	1391	1436
	10	550	870	1180	1602	2022	2249	2472	
	30	574	1654	2704	3376	4016	4364		
	45	991	2202	3302	3991				
	60	1096	2503	3896	3887				
	75	1640	3624						
	100	1739	3863						
	150	2256	5007						
1.25 psi (0.5 - 1.75 psi) 0.2 psi Droop	5	216	326	525	473	630	557	788	1103
	10	283	401	629	644	943	801	1100	1022
	30	344	580	1017	970	1253	1409		
	45	493	781	1233	1192	1438			
	60	668	1068	1602	1496	1736			
	75	717	1278	1932					
	100	1003	1754	2590					
	150	1266	2256	3356					
3 psi (1 - 3.5 psi) 0.3 psi Droop	5	173	259	347	377	404	445	481	809
	10	252	376	503	605	713	753	797	881
	30	279	578	866	967	1062	1404		
	45	493	781	1130	1192	1192			
	60	662	1068	1472	1496	1509			
	75	717	1278	1776					
	100	929	1754	2602					
	150	1211	2256	3356					

MARK 608IS SERIES GAS PRESSURE REGULATORS

DIMENSIONS (NPT, SWE, BSPT, BSPP ENDS)

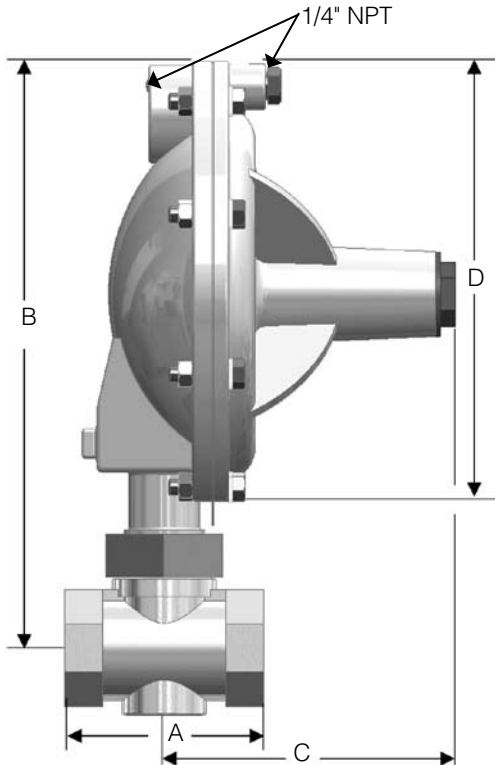

Valve Size	Dimensions (inches)				Weight lbs
	A	B	C	D	
3/4"	3.88	11.31	5.75	9.00	15
1"	3.88	11.31	5.75	9.00	15
1-1/4"	3.88	11.31	5.75	9.00	15

Valve Size	Dimensions (mm)				Weight kgs
	A	B	C	D	
DN20	99	287	146	229	6,8
DN25	99	287	146	229	6,8
DN32	99	287	146	229	6,8

DIMENSIONS (FLANGED ENDS)

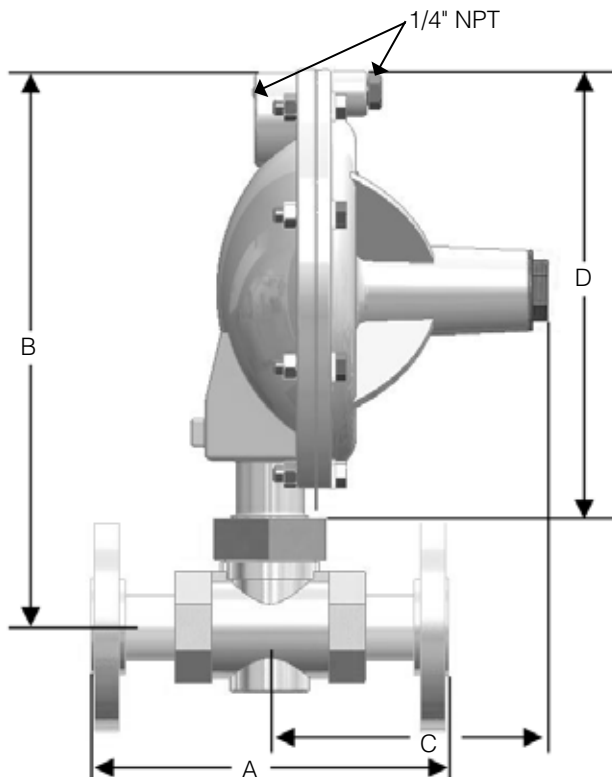

Valve Size	Ends	Dimensions (inches)			
		A	B	C	D
3/4"	150FE	7.25	11.31	5.75	9.00
	300FE	7.50	11.31	5.75	9.00
1"	150FE	7.25	11.31	5.75	9.00
	300FE	7.75	11.31	5.75	9.00
1-1/4"	150FE	7.87	11.31	5.75	9.00
	300FE	8.35	11.31	5.75	9.00

Valve Size	Ends	Dimensions (mm)			
		A	B	C	D
DN20	150FE	184	287	146	229
	300FE	191	287	146	229
DN25	150FE	184	287	146	229
	300FE	197	287	146	229
DN32	150FE	200	287	146	229
	300FE	212	287	146	229

ORDERING SCHEMATIC

Model No	Size	Body Mat'l	1	2	3	4	5	6	7	8	9	10	11	12

Model	
608IS	Standard

Size	
075	3/4" (DN20)
100	1" (DN25)
125	1-1/4" (DN32)

Body Material	
DI	Ductile Iron
CS	Carbon Steel (WCB)
S6	Stainless Steel (CF8M)

1 & 2	End Connections
PT	NPT
BP	BSPT
BP	BSPP
SW	FSW
F1	125# FE
F5	150# FE
F2	250# FE
F3	300# FE
F7	PN10 DIN FE
F6	PN16 DIN FE
F8	PN25 DIN FE
F4	PN40 DIN FE
ZZ	Non-Standard

3 & 4	Seats
01	1/8" (3mm)
02	3/16" (5mm)
03	1/4" (6mm)
04	5/16" (8mm)
05	3/8" (10mm)
06	7/16" (11mm)
07	1/2" (13mm)
08	9/16" (14mm)
ZZ	Non-Standard

5 & 6	Range	
	W.C.	mbar
01	1 - 2.5" W.C.	2,5 - 6,2 mbar
02	2 - 5.5" W.C.	5,0 - 13,7 mbar
03	4 - 10" W.C.	10,0 - 24,9 mbar
04	5 - 30" W.C.	12,4 - 74,7 mbar
05	0.5 - 1.75" psi	0,03 - 0,12 bar
06	1 - 3.5 psi	0,07 - 0,24 bar

7 & 8	Actuator
SD	Standard
ZZ	Non-Standard

9 & 10	Bushing
00	None

11 & 12	PED Confirmation
00	Not Required
FF	CE Category 1
ZZ	Non-Standard

