



NIC Instruments & Engineering (Pty) Ltd

Service to the Industry Since 1986

P O Box 39606, Bramley, 2018
74 12th Road, Kew, Johannesburg
South Africa
Tel: +27 11 386 5000
Fax: +27 11 887 5728
E-Mail: sales@nicinst.co.za
Website: www.nicinst.co.za

MOUNT YOUR EQUIPMENT IN A FIELD PROTECTION BOX



- Corrosion resistant
- Weather, hose and dust proof
- Suitable for purging
- Impact resistant
- Reduce Installation costs - have your equipment prepiped/wired in an FPB (prices on request)
- Versatile mounting of box and equipment. Refer to dimension drawings on reverse.

- ❖ Pre-pigmented gell coated finish
- ❖ Laminated fiberglass
- ❖ Toughened glass front window
- ❖ Lockable stainless steel catch
- ❖ Safety latch stay to hold cover open
- ❖ Tag No. Description label recess



DURBAN P. O. Box 37201 Overport 4067 Tel:031 202 7490 | SECUNDA P. O. Box 3561 Secunda 2302 Tel:017 634 6836/4 | RICHARDS BAY P. O. Box 2852 Richards Bay 3900 Tel:035 789 2178
RUSTENBURG P. O. Box 39606 Bramley Tel:014 534 0901/2 | VAAL P. O. Box 39606 Bramley 2018 Tel:016 981 6140/1/2



Electrical Contracting Board
Registration No. TN1-004503

NOSA



Certificate No.5971

NIC Directors: M.J. Clough, D.L Erasmus, J.A. Ferreira, J. Joubert, B. Wakeford
NIC Empowerment Trust
Reg. No.: 1986/002515/07

cidb

Registration No. 131893

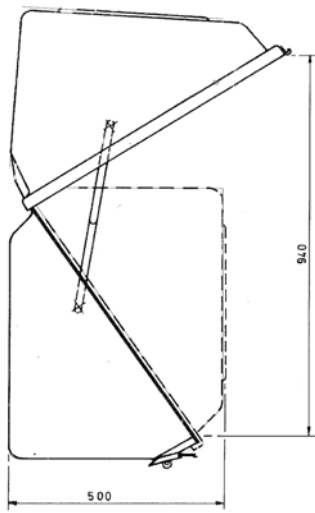

PRESS MOULDED PROTECTION BOX

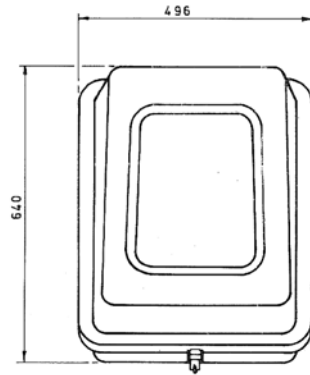

Laminated fiberglass Pre-pigmented gell coated finish.
 Safety stay to maintain cover in open position.
 Security catch is fitted as standard.
 Safety glass window for inspection without opening box.

Part No.: NIC-BX1
 Large: 640 H x 500 W x 500 D
Part No.: NIC-BX4
 Medium: 430 H x 370 W x 330 D

BOX MOUNTING YOKE

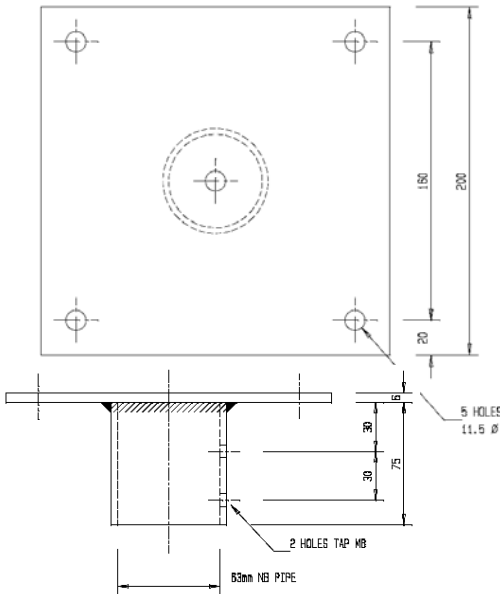

Electro galvanized Mild steel.
 To suit 50mm N.B. Mounting post Or bracket

Part No.: NIC-A1

INSTRUMENT MOUNTING PILLAR

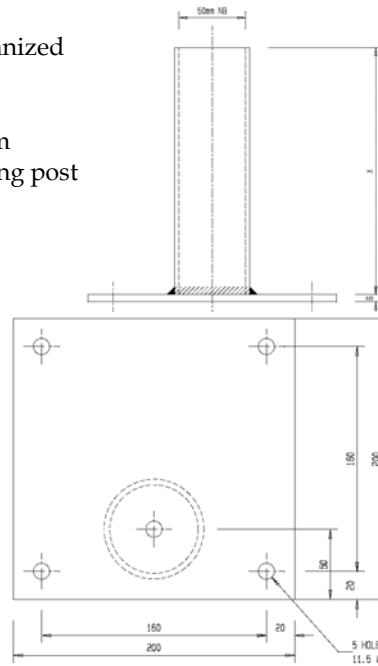

Yellow Passivated Mild steel.
 To suit standard Instrument "U" bolt fittings

Large: 400mm
Part No.: NIC-A3D
 Medium: 300mm
Part No.: NIC-A3E

BOX MOUNTING POST

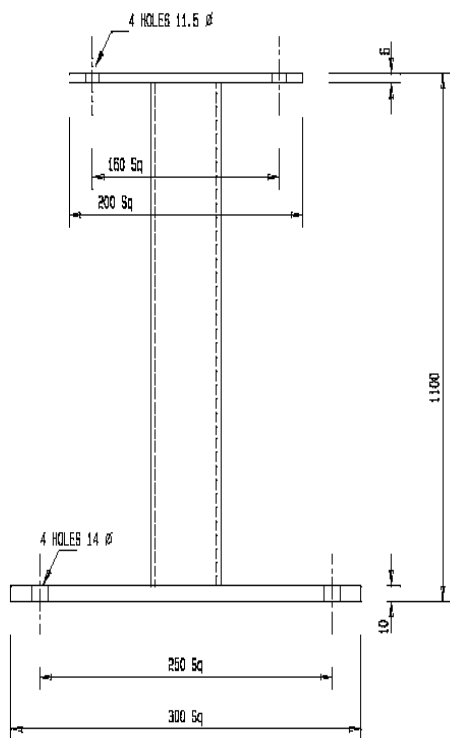

Hot dipped Galvanized Mild steel
 1,1m High

Part No.: NIC-A2

INSTRUMENT MOUNTING PLATE

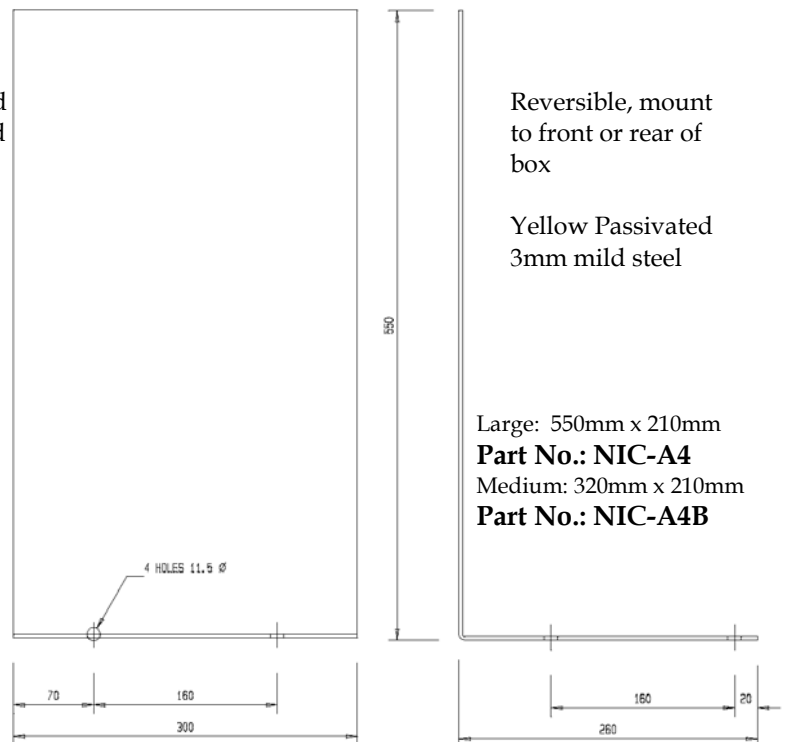

Reversible, mount to front or rear of box
 Yellow Passivated 3mm mild steel

Large: 550mm x 210mm
Part No.: NIC-A4
 Medium: 320mm x 210mm
Part No.: NIC-A4B