



Echotel® Model 910 Ultrasonic Level Switch

DESCRIPTION

Echotel Model 910 Level Switches utilize ultrasonic contact technology for measuring level in clean liquid applications. The dual conduit hub electronics houses a 10-amp DPDT gold flash relay that is field selectable for high or low level fail-safe applications. There are no moving parts that come in contact with the medium. The Echotel Model 910 is an integrally mounted system, comprised of surface mount electronics and a 316 stainless steel transducer. Hazardous area location approvals are available from FM, CSA, and ATEX.

FEATURES

- Measures level within 0.25" (6 mm) from the end of the tip-sensitive transducer gap
- 10-amp DPDT gold flash or 5-amp DPDT hermetically sealed relay
- Surface mount conformal coated electronics
- FM, CSA, and ATEX approved for hazardous locations
- Variety of mounting options including NPT and BSP threaded, flanges and sanitary connections
- No calibration required
- 316 stainless steel transducer
- May be mounted either horizontally or vertically
- Compact NEMA 4X/7/9 dual conduit hub cast aluminum electronics housing
- Available in 14 standard actuation lengths from 1" to 96" (2.5 to 244 cm)
- Two-year product warranty



APPLICATIONS

- Water and wastewater
- Food and beverage
- Pulp and paper
- Petrochemical
- Power
- Pharmaceutical
- Chemical

TECHNOLOGY

The Model 910 Level Switch uses ultrasonic energy to detect the presence or absence of liquid in a 316 SS tip sensitive transducer gap. The basic principle behind ultrasonic contact technology is that high-frequency sound waves are easily transmitted across a transducer gap in the presence of a liquid medium, but are severely attenuated when the gap is dry. The Model 910 uses an ultrasonic frequency of 3 MHz to perform this liquid level measurement in a wide variety of process media and application conditions.

The transducer uses a pair of piezoelectric crystals that are encapsulated in epoxy at the tip of the transducer. The crystals are made of a ceramic material, such as lead zirconate. The transmit crystal converts an electrical signal from the Model 910 electronics into an ultrasonic signal. When liquid is present in the gap, the receive crystal is able to sense the ultrasonic signal from the transmit crystal and convert it back to an electrical signal. This signal is sent to the electronics to indicate the presence of liquid in the transducer gap. When there is no liquid present, the ultrasonic signal is attenuated, and the receive crystal is not able to sense the sound waves from the transmit crystal.

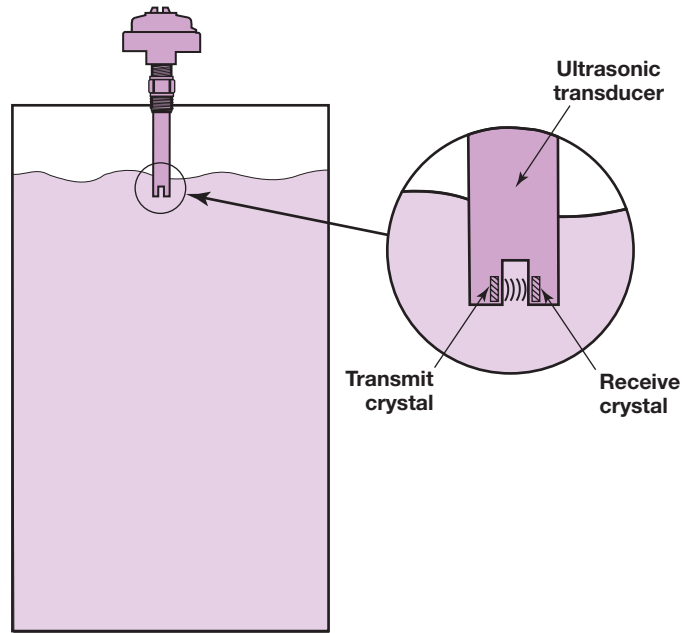

Ultrasonic signal transmission across transducer gap

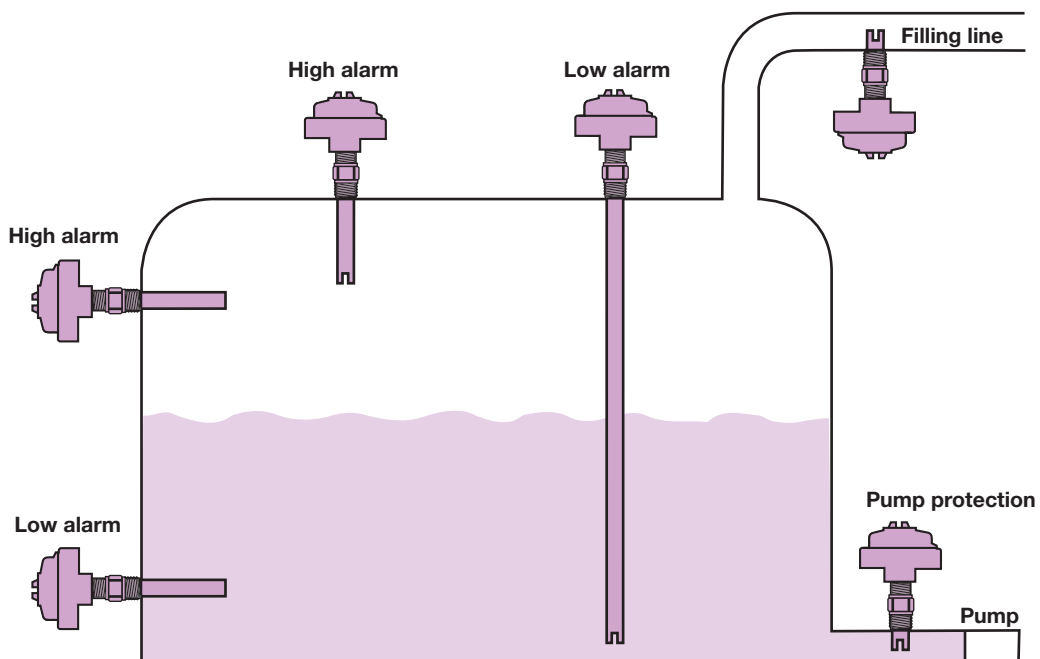

Typical applications and mounting positions

SWITCH

MODEL NUMBER

Models available for quick shipment, usually within one week after factory receipt of a purchase order, through the Expedite Ship Plan (ESP)

HOUSING

| | |
|---|--|
| A | Aluminum sand cast with 3/4" NPT dual conduit, FM and CSA approvals |
| Y | 316 stainless steel with 3/4" NPT single conduit, FM and CSA approvals |
| P | Aluminum sand cast with 3/4" NPT dual conduit, FM, CSA, and ATEX approvals |
| 5 | 316 stainless steel with 3/4" NPT single conduit, ATEX approval |

TRANSDUCER UNIT OF LENGTH

| | |
|---|--|
| 1 | English (actuation length in inches) |
| M | Metric (actuation length in centimeters) |

PROCESS CONNECTION

| | |
|---|---|
| A | 3/4" NPT |
| 2 | 1" NPT |
| 9 | 1" BSP |
| 3 | 1 1/2" sanitary 16 AMP fitting (compatible with Tri-Clover® Tri-Clamp®) |
| 4 | 2" sanitary 16 AMP fitting (compatible with Tri-Clover Tri-Clamp) |
| 1 | 1" 150 lb. ASME raised face flange |
| C | 1 1/2" 150 lb. ASME raised face flange |
| D | 2" 150 lb. ASME raised face flange |
| E | 1" 300 lb. ASME raised face flange |
| F | 1 1/2" 300 lb. ASME raised face flange |
| G | 2" 300 lb. ASME raised face flange |

INPUT POWER

| | |
|---|---|
| 0 | 120 VAC with 10-amp DPDT gold flash relay |
| 1 | 240 VAC with 10-amp DPDT gold flash relay |
| 2 | 24 VDC with 10-amp DPDT gold flash relay |
| H | 120 VAC with 5-amp DPDT hermetically sealed relay |
| J | 240 VAC with 3-amp DPDT hermetically sealed relay |
| K | 24 VDC with 5 amp DPDT hermetically sealed relay |

ACTUATION LENGTH

| |
|---|
| 1" to 96" in 1" increments (with Transducer Unit of Length code 1) Example: 4 inches = 004 ① ③ |
| 3 cm to 244 cm in 1 cm increments (with Transducer Unit of Length code M) Examples: 6 centimeters = 006 ② ③ |
| Available ESP lengths ④ : 1", 2", 4", 6", 8", 12", 16", 22" |



① 1" (code 001) minimum with NPT process connections, 2" (code 002) minimum with sanitary or ASME flanged process connections.

② 2.5 cm (code 003) minimum with NPT process connections, 5 cm (code 005) minimum with 1" BSP, or sanitary or ASME flanged process connections.

③ Consult factory for longer lengths.

④ Consult factory for ESP metric length codes.

DIMENSIONAL SPECIFICATIONS

INCHES (MM)

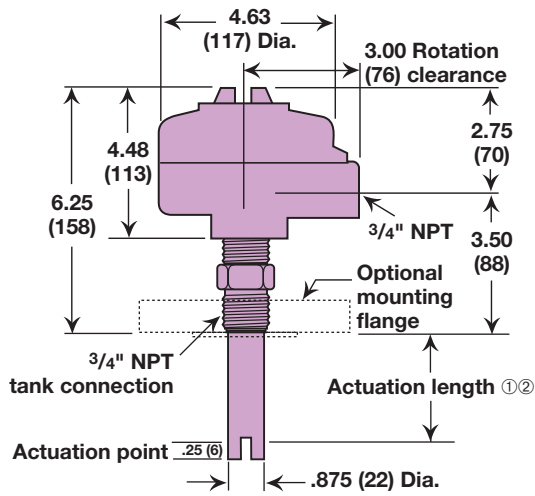

**NEMA 4X/7/9, 316 stainless steel housing
3/4" NPT single conduit**

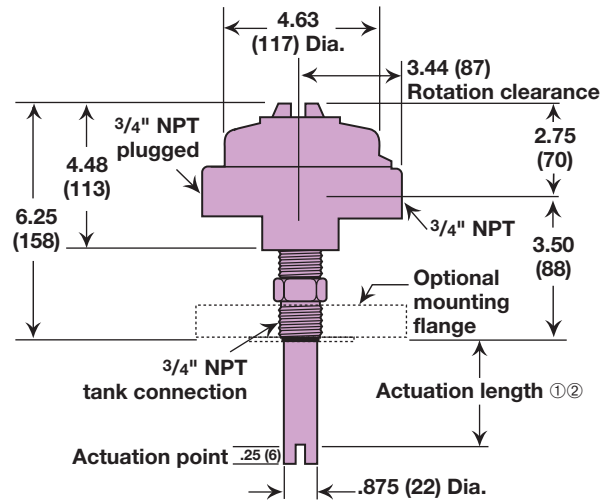

**NEMA 4X/7/9, aluminum sand cast housing
3/4" NPT dual conduits**

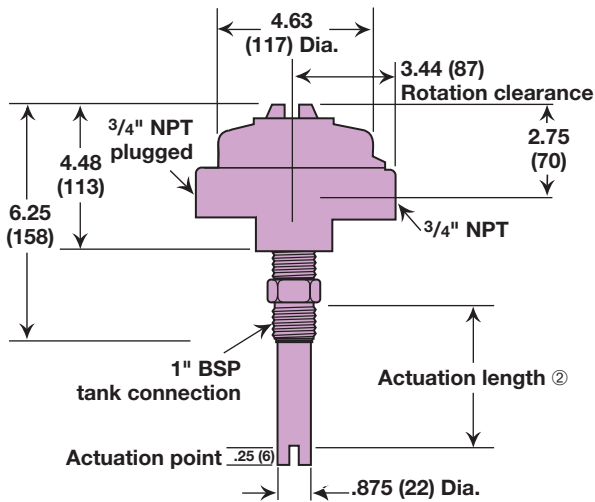

**NEMA 4X/7/9, aluminum sand cast housing
3/4" NPT dual conduit (w/1" BSP process connection)**

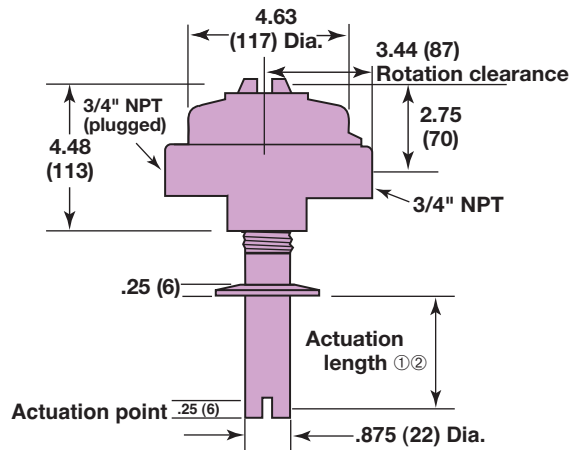

**NEMA 4X/7/9, aluminum sand cast housing
3/4" NPT dual conduit (with sanitary flange)**

① 1" minimum with NPT threaded process connections.
2" minimum with sanitary or ASME flanged process connections.

② 25 mm minimum with NPT threaded process connections.
50 mm minimum with 1" BSP and sanitary or ASME flanged process connections.





ELECTRICAL SPECIFICATIONS

| | |
|-----------------------------------|--|
| Power Supply: | 120 VAC (+10%/-15%), 50/60 Hz 240 VAC (+10%/-15%), 50/60 Hz 24 VDC (±10%) |
| Power Consumption: | 2.5 VA nominal |
| Relay Output: | Gold flash DPDT ^① : 10 amps @ 120 VAC, 10 amps @ 240 VAC 10 amps @ 24 VDC, 0.5 amps @ 125 VDC Hermetically sealed DPDT: 5 amps @ 120 VAC, 3 amps @ 240 VAC 5 amps @ 24 VDC |
| Repeatability: | 0.078" (2 mm) |
| Fail-safe: | Field selectable high or low |
| Calibration: | None required |
| Ambient Temperature: | Electronics: -40° to +160° F (-40° to +71° C) ^② |
| Process Temperature: | Transducer: -40° to +250° F (-40° to +121° C) |
| Shock: | ANSI/ISA-S71.03 Class SA1 |
| Vibration: | ANSI/ISA-S71.03 Class VC2 |
| Operating/Non-Operating Pressure: | 800/1500 psig (55/103 bar) |

^① Gold flash DPDT relay is rated at 8 amps when used with housing codes 5 or P

^② Electronics are rated -40° to +104° F (-40° to +40° C) with the ATEX housing code 5

AGENCY APPROVALS

| AGENCY | MODEL APPROVED | APPROVAL CATEGORY | APPROVAL CLASSES |
|---|------------------------------|-------------------|---|
|  | 910-XXXX-XXX | Explosion Proof | Class I, Div. 1; Groups C & D Class II, Div. 1; Groups E, F, & G Class III, NEMA Type 4X, T6 |
| | 910-XXXX-XXX | Non-Incendive | Class I, Div. 2; Groups A, B, C, & D Class II, Div. 2; Groups F & G Class III, NEMA Type 4X, T5 |
|  | 910-XXXX-XXX | Explosion Proof | Class I, Div. 1; Groups C & D Class II, Div. 1; Group E, F, & G Class III, Type 4X, T6 |
| | 910-XXXX-XXX | Non-Incendive | Class I, Div. 2; Groups A, B, C, & D Class II, Div. 2; Groups E, F, & G Class III, Type 4X, T5 |
|  | 910-5XXX-XXX 910-PXXX-XXX | |  II 1/2 G EEx d IIC T6/ EEx e II T6 |

Note: Consult factory for Brazilian INMETRO Ex d IIC T6 approval from CEPEL



These units have been tested to EN 50081-2 and EN 50082-2 and are in compliance with the EMC Directive 89/336/EEC.

QUALITY

MAGNETROL
REGISTERED TO
ISO 9001
Your Assurance of
Quality and Service

The quality assurance system in place at Magnetrol guarantees the highest level of quality throughout the company. Magnetrol is committed to providing full customer satisfaction both in quality products and quality service.

Magnetrol's quality assurance system is registered to ISO 9001 affirming its commitment to known international quality standards providing the strongest assurance of product/service quality available.

ESP

Expedite
Ship
Plan

Several Echotel Model 910 Ultrasonic Level Switches are available for quick shipment, usually within one week after factory receipt of a purchase order, through the Expedite Ship Plan (ESP).

Models covered by ESP service are conveniently color coded in the selection data charts.

To take advantage of ESP, simply match the color coded model number codes (standard dimensions apply).

ESP service may not apply to orders of ten units or more. Contact your local representative for lead times on larger volume orders, as well as other products and options.

QUALITY



All Magnetrol Model 910 Level Switches are warranted free of defects in materials or workmanship for two full years from the date of original factory shipment.

If returned within the warranty period; and, upon factory inspection of the control, the cause of the claim is determined to be covered under the warranty; then, Magnetrol will repair

or replace the control at no cost to the purchaser (or owner) other than transportation.

Magnetrol shall not be liable for misapplication, labor claims, direct or consequential damage or expense arising from the installation or use of equipment. There are no other warranties expressed or implied, except special written warranties covering some Magnetrol products.

For additional information, see Instruction Manual 51-604.



5300 Belmont Road • Downers Grove, Illinois 60515-4499 • 630-969-4000 • Fax 630-969-9489 • www.magnetrol.com
145 Jardin Drive, Units 1 & 2 • Concord, Ontario Canada L4K 1X7 • 905-738-9600 • Fax 905-738-1306
Heikensstraat 6 • B 9240 Zele, Belgium • 052 45.11.11 • Fax 052 45.09.93
Regent Business Ctr., Jubilee Rd. • Burgess Hill, Sussex RH15 9TL U.K. • 01444-871313 • Fax 01444-871317

Copyright © 2007 Magnetrol International, Incorporated. All rights reserved. Printed in the USA.
Performance specifications are effective with date of issue and are subject to change without notice.
Magnetrol & Magnetrol logotype and Echotel® are registered trademarks of Magnetrol International.
Tri-Clamp® is a registered trademark of Ladish Co.
Tri-Clover® is a registered trademark of Tri-Clover, Inc.

BULLETIN: 51-105.15
EFFECTIVE: April 2005
SUPERSEDES: September 2004