



CENTER LINE[®]

Resilient Seated Butterfly Valves



Center Line has been a market leader in quarter-turn valves for more than 40 years, and we have earned a reputation as a supplier of superior valves at competitive prices. Our goal is to exceed industry requirements and customer expectations.

We are committed to offering products that meet a wide range of applications and requirements. We continually improve our product line by introducing new products and enhancing existing designs, providing our customers with the best products on the market.

Our complete line of resilient seated butterfly valves provides you with the reliability you need, backed by the guarantee that comes with using valves designed and produced in company-owned manufacturing facilities.

Center Line Resilient Seated Butterfly Valves Product Features

- Qualified for both gaseous and liquid service
- Positive shut-off bi-directionally
- Phenolic backed cartridge seat
- Three-position PTFE bushing standard
- Locking handle standard
- End of line service optional
- Ease of automation
- Field repairable
- Complete size range: 2 through 48 inches

Typical Applications

- HVAC
- Chemical/ Petrochemical Processing
- Food and Beverage
- Power and Utilities
- Pulp and Paper

NOTE: In keeping with our policy of continuing improvement, we reserve the right to institute changes in design, material, dimensions, or specifications without notice and without incurring any obligation to make such changes and modifications on product previously or subsequently sold.

Quality is designed into Series 200, 225, and 250 butterfly valves from Center Line. These valves feature a phenolic-backed cartridge seat and precision-machined parts to assure years of dependable operation.

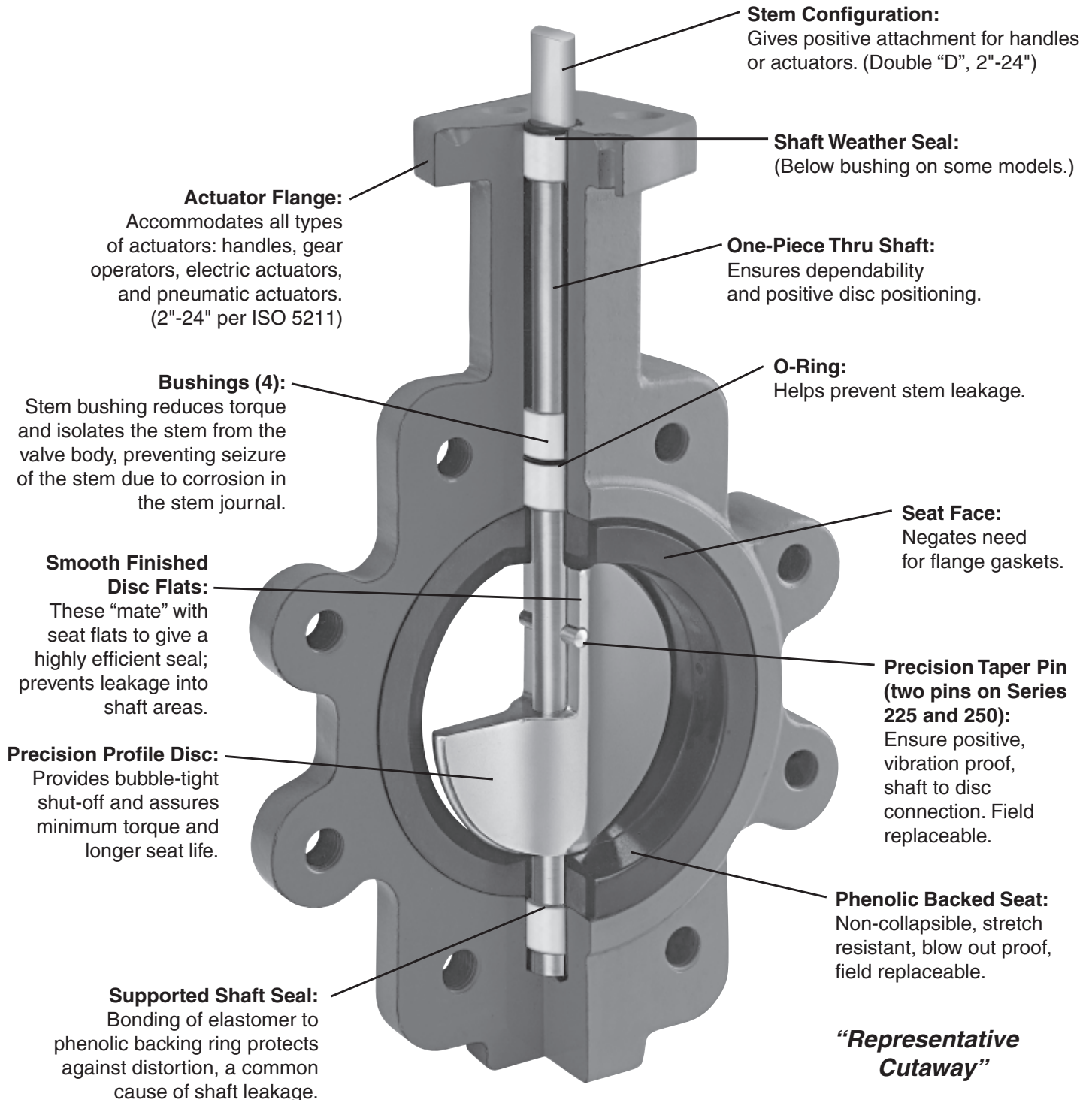

- Available in sizes 2" to 48".
- Available in Wafer or Lug style body (2" to 30").
- Full flange style body for 36" to 48" valves.
- Wafer body features four alignment holes.
- Pressure ratings for tight shut-off at temperatures up to the maximum limit of the seat material:
 - 2" to 12" — 200 psi, 125 psi for PTFE seat.
 - 14" to 48" — 150 psi.
- Ideal for on-off or throttling services.
- Available with handles (2" to 12"), manual gear operators (2" to 48"), and electric or pneumatic actuators (2" to 48").
- Refer to Crane automation bulletin for details of pneumatic and electric actuators.
- Designed to comply with MSS SP-67.
- Compatible with ASME 125/150 flanges.
- Valves 2" to 20" meet the intent and have passed the AWWA C-504-87 Section 5 proof of design tests.
- Type approval certification from ABS for marine applications (2" to 14").
- Bi-directional dead-end capability to 200 psi (2" to 12") and 150 psi (14" to 24") is standard on lug valves.
- Operators mounted perpendicular to pipe.
- For bolting information, consult the Center Line Installation and Maintenance Manual.
- Vacuum Service Rating: zero leakage at 24" of mercury.
- Commercial cleaning available for non-silicone and O₂ service.

Valve Seating Torques (In-Lbs.) 2" to 30"

Valve Size	Standard Disc Differential Pressure								Undercut Diff. Press.	
	50 PSI ΔP Bushing		100 PSI ΔP Bushing		150 PSI ΔP Bushing		200 PSI ΔP Bushing		75 PSI ΔP Bushing	
	Bronze	PTFE	Bronze	PTFE	Bronze	PTFE	Bronze	PTFE	Bronze	PTFE
2"	106	100	117	106	129	111	140	117	-	-
2 1/2"	152	150	166	163	181	176	195	189	-	-
3"	213	207	230	220	248	232	265	244	-	-
4"	321	290	386	323	450	357	515	390	-	-
5"	481	423	598	481	715	540	832	598	-	-
6"	692	599	878	691	1,063	783	1,248	875	-	-
8"	1,326	1,060	1,716	1,183	2,106	1,307	2,496	1,430	1,124	819
10"	2,239	1,671	3,010	1,872	3,780	2,074	4,550	2,275	1,363	909
12"	3,959	2,568	4,953	2,795	5,948	3,023	6,942	3,250	2,457	1,445
14"	4,881	2,640	6,226	3,070	7,570	3,500	-	-	4,400	2,300
16"	7,020	4,260	8,580	4,880	10,140	5,500	-	-	5,900	3,600
18"	10,105	6,287	12,202	7,243	14,300	8,200	-	-	8,300	5,500
20"	13,923	8,360	16,582	9,180	19,240	10,000	-	-	11,100	6,700
24"	23,617	15,427	26,953	16,813	30,290	18,200	-	-	17,300	12,100
30"	39,721	27,313	43,391	29,407	47,060	31,500	-	-	27,300	21,100

Valve Seating Torques (In-Lbs.) 28" to 48" Double Flanged

Valve Size	Standard Disc Differential Pressure		
	50 PSI Wet / Dry	100 PSI Wet / Dry	150 PSI Wet / Dry
28"	23,718	26,639	28,957
30"	28,320	30,860	33,338
32"	32,418	35,073	38,126
36"	40,622	43,480	46,524
40"	68,924	74,048	78,995
42"	69,747	74,632	79,862
48"	96,598	103,837	111,112

All torques shown in these charts were derived from test data using water at 60°F. For torques using dry gases, multiply these numbers by 2.0. For torques involving other media, please consult the factory.

There is no safety factor included in the numbers shown on these charts. For actuator sizing, Crane recommends that these values be multiplied by 1.5 for single valve applications, or 2.0 for 3-way ("tee") applications.

For PTFE seats multiply the numbers shown by 2.0.

Under certain conditions, hydrodynamic torque can meet or exceed seating and unseating torques. When designing valve systems, hydrodynamic torque must be considered to help assure correct selection for the application.

Seat Temperature Ratings

Material	Temperature Ratings °F
Buna-N	+10 to 180
Abrasive Resistant Buna-N	+10 to 180
Neoprene	+20 to 200
EPDM (2" - 16")	-30 to 275
EPDM (18" & Above)	-30 to 225
EPDM, Food Grade (2" - 12")	-30 to 225
Hypalon	0 to 275
Viton	+10 to 275
High Temp. Viton	+10 to 400
PTFE over Buna-N (125 psi, 2" - 12")	+40 to 250
PTFE over Buna-N (75 psi, 2" - 12")	+40 to 275

Although elastomers have an effective operating temperature range, when used in valves, these ranges may have to be modified. The temperature ranges shown in the table have been adjusted accordingly.

For Low Temperature: While the seat materials selected for use in Center Line butterfly valves are capable of withstanding lower temperatures without damage, the durometer of the elastomer is changed. This "hardening" of the seat may increase the operating torque beyond the structural limits of the stem and/or the disc to stem configuration.

For High Temperature: When using High Temperature Viton, the operating pressure of the valve is reduced above 275°F.

C_v Values – Valve Sizing Coefficients (US-GPM @ 1ΔP) 2" to 48"

Size	10°	20°	30°	40°	50°	60°	70°	80°	90°
2"	0.06	3	7	15	27	44	70	105	115
2 1/2"	0.10	6	12	25	45	75	119	178	196
3"	0.20	9	18	39	70	116	183	275	302
4"	0.30	17	36	78	139	230	364	546	600
5"	0.50	29	61	133	237	392	620	930	1022
6"	0.80	45	95	205	366	605	958	1437	1579
8"	2	89	188	408	727	1202	1903	2854	3136
10"	3	151	320	694	1237	2047	3240	4859	5340
12"	4	234	495	1072	1911	3162	5005	7507	8250
14"	6	338	715	1549	2761	4568	7230	10844	11917
16"	8	464	983	2130	3797	6282	9942	14913	16388
18"	11	615	1302	2822	5028	8320	13168	19752	21705
20"	14	791	1647	3628	6465	10698	16931	25396	27908
24"	22	1222	2587	5605	9989	16528	26157	39236	43116
28"	36	1813	3639	6636	10000	14949	22769	34898	49500
30"	37	2080	4406	9546	17010	28147	44545	66818	73426
32"	45	2387	4791	8736	13788	20613	31395	48117	38250
36"	260	3050	6730	12740	20220	32500	52500	79600	87500
40"	84	4183	8395	15307	24159	36166	55084	84425	119750
42"	350	4095	9040	17108	27150	43640	70500	106890	117500
48"	455	5365	11840	22400	30600	51200	92300	140000	154000

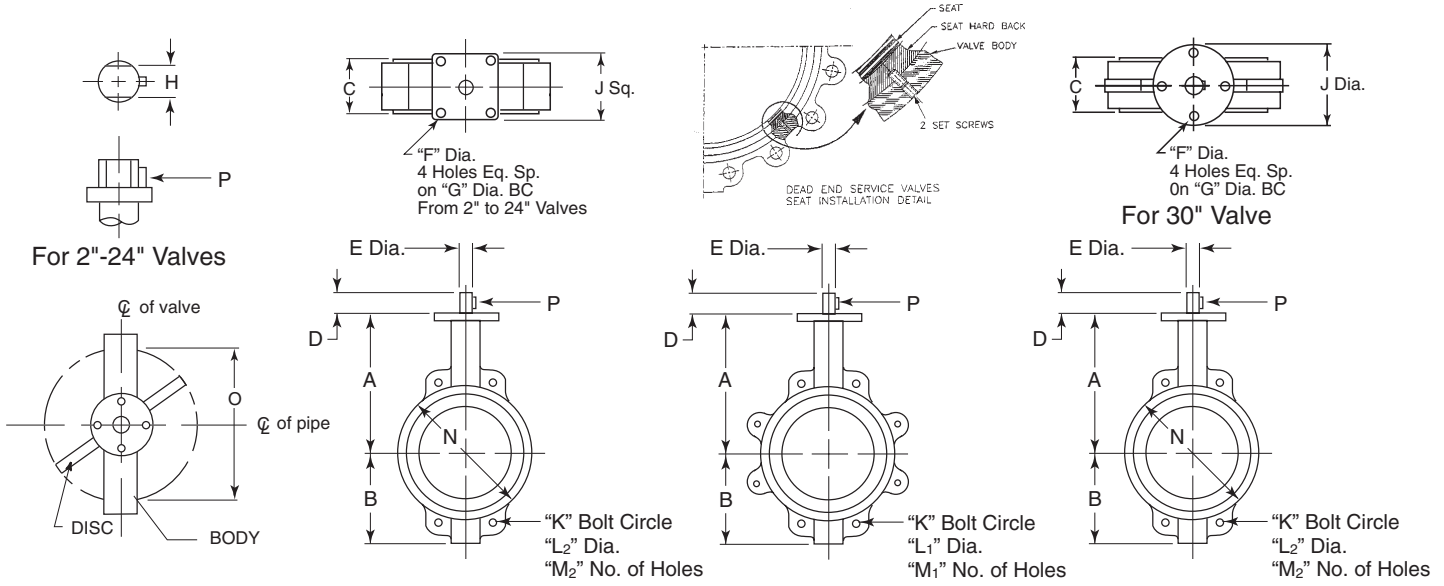

Dimensions 2" - 30"

Inches / mm	A	B	C	D	E	F	G	H	J	K	L ₁	L ₂	M ₁	M ₂	N	O	P
2"	6 3/8	3 1/4	1 3/4	1 1/4	1/2	3/8	2.76	0.39	2 3/4	4 3/4	3/8-11	1 1/8	4	4	4	1.26	Wooduff #3
50	161.93	82.55	44.45	31.75	12.70	9.53	70	10	69.85	120.65	17.46	17.46	4	4	101.60	32.0	
2 1/2"	6 7/8	3 3/4	1 7/8	1 1/4	1/2	3/8	2.76	0.39	2 3/4	5 1/2	3/8-11	1 1/8	4	4	4 3/4	1.83	Wooduff #3
65	174.63	95.25	47.63	31.75	12.70	9.53	70	10	69.85	139.70	17.46	17.46	4	4	120.65	46.5	
3"	7 1/8	4	1 7/8	1 1/4	1/2	3/8	2.76	0.39	2 3/4	6	3/8-11	1 1/8	4	4	5 1/2	2.54	Wooduff #3
75	180.98	101.60	47.63	31.75	12.70	9.53	70	10	69.85	152.40	17.46	17.46	4	4	130.18	64.5	
4"	7 7/8	4 7/8	2 1/8	1 1/4	5/8	3/8	2.76	0.47	2 3/4	7 1/2	3/8-11	1 1/8	8	4	6 3/4	3.54	Wooduff #9
100	200.03	123.83	53.98	31.75	15.88	9.53	70	12	69.85	190.50	17.46	17.46	8	4	171.45	89.9	
5"	8 3/8	5 3/8	2 1/4	1 1/4	3/4	3/8	2.76	0.55	2 3/4	8 1/2	3/8-10	1 3/8	8	4	7 3/4	4.36	Wooduff #9
125	212.73	136.53	57.15	31.75	19.05	9.53	70	14	69.85	215.90	20.64	20.64	8	4	196.85	110.7	
6"	8 7/8	5 7/8	2 1/2	1 1/4	3/4	3/8	2.76	0.55	2 3/4	9 1/2	3/8-10	1 3/8	8	4	8 3/8	5.72	Wooduff #9
150	225.43	149.23	57.15	31.75	19.05	9.53	70	14	69.85	241.30	20.64	20.64	8	4	219.08	145.3	
8"	10 1/4	7 3/4	2 1/2	1 3/4	7/8	7/16	4.02	0.67	3 3/4	11 3/4	3/8-10	1 3/8	8	4	10 3/8	7.6	Wooduff #9
200	260.35	196.86	63.50	44.45	22.23	11.11	102	17	95.33	298.45	20.64	20.64	8	4	268.29	193.0	
10"	11 1/2	8 1/4	2 3/4	1 3/4	1 1/8	7/16	4.02	0.87	3 3/4	14 1/4	7/8-9	1 3/8	12	4	13 3/8	9.5	Wooduff #15
250	292.10	209.55	69.85	44.45	28.58	11.11	102	22	95.33	361.95	23.81	23.81	12	4	331.79	241.3	
12"	13 1/4	9 3/4	3 3/8	1 3/4	1 1/4	7/16	4.02	0.95	3 3/4	17	7/8-9	1 3/8	12	4	16 1/8	11.45	Wooduff #15
300	336.55	247.65	79.38	44.45	31.75	11.11	102	24	95.33	431.80	23.81	23.81	12	4	409.58	290.8	
14"	14 1/2	11	3 3/8	1 3/4	1 1/4	7/16	4.02	0.95	3 3/4	18 3/4	1-8	1 3/8	12	4	17 1/8	12.78	Wooduff #15
350	368.30	279.40	79.38	44.45	31.75	11.11	102	24	95.33	476.25	26.99	26.99	12	4	434.98	324.6	
16"	15 3/4	12	3 1/2	2	1 1/8	7/8	6.50	1.06	6 1/2	21 1/4	1-8	1 3/8	16	4	20	14.97	3/8" Sq. x 1 3/4"
400	400.05	304.80	88.90	50.80	33.34	22.23	165	27	165.10	539.75	26.99	26.99	16	4	508.00	380.2	
18"	16 3/8	15	4 1/4	2	1 1/2	7/8	6.50	1.06	6 1/2	22 3/4	1 1/8-7	1 1/4	16	4	21 3/8	16.83	3/8" Sq. x 1 1/2"
450	422.28	381.00	107.95	50.80	38.10	22.23	165	27	165.10	577.85	31.75	31.75	16	4	542.93	427.5	
20"	18 7/8	14 3/8	5 1/4	2 1/2	1 3/8	7/8	6.50	1.26	6 1/2	25	1 1/8-7	1 1/4	20	4	23 3/8	18.67	3/8" Sq. x 1 3/4"
500	479.43	371.48	133.35	63.50	41.28	22.23	165	32	165.10	635.00	31.75	31.75	20	4	592.14	474.2	
24"	22 1/8	18	6 1/8	2 3/4	2	7/8	6.50	1.42	6 1/2	29 1/2	1 1/4-7	1 1/4	20	4	27 3/8	22.62	1/2" Sq. x 2 1/4"
600	561.98	457.20	155.58	69.85	50.80	22.23	165	36	165.10	749.30	31.75	31.75	20	4	708.03	574.5	
30"	25 1/2	24 1/4	6 3/4	3 1/4	2 1/2	7/8	8 1/2	N/A	11 1/4	36	1 1/4-7	1 1/4	28	4	34 3/8	28.6	3/8" Sq. x 2 5/8"
750	647.70	615.95	171.45	82.55	63.50	22.23	215.90		285.75	914.40	31.75	31.75			873.13	726.4	

L₁ and M₁ refer to Lug style valves, L₂ and M₂ refer to Wafer Style. "C" dimension is listed with elastomer in the relaxed condition. Approximately 1/8" total compression is required for proper sealing with pipe flanges. Valves are designed for installation between ASME B16.1 Class 125 (Iron) and B16.5 Class 150 (Steel) flanges. Gaskets are not needed, and should not be used since the seat face seals against the mating flange. If the valve is to be installed in plastic or fiberglass flanges, flange rings, or Van Stone style flanges, consult your Center Line agent or the factory for additional information. Center Line recommends that a blind flange be used on end of line applications.

Consult factory for dimension to 2 1/2" and 5" PTFE seated valves. "O" dimension is the valve clearance dimension.

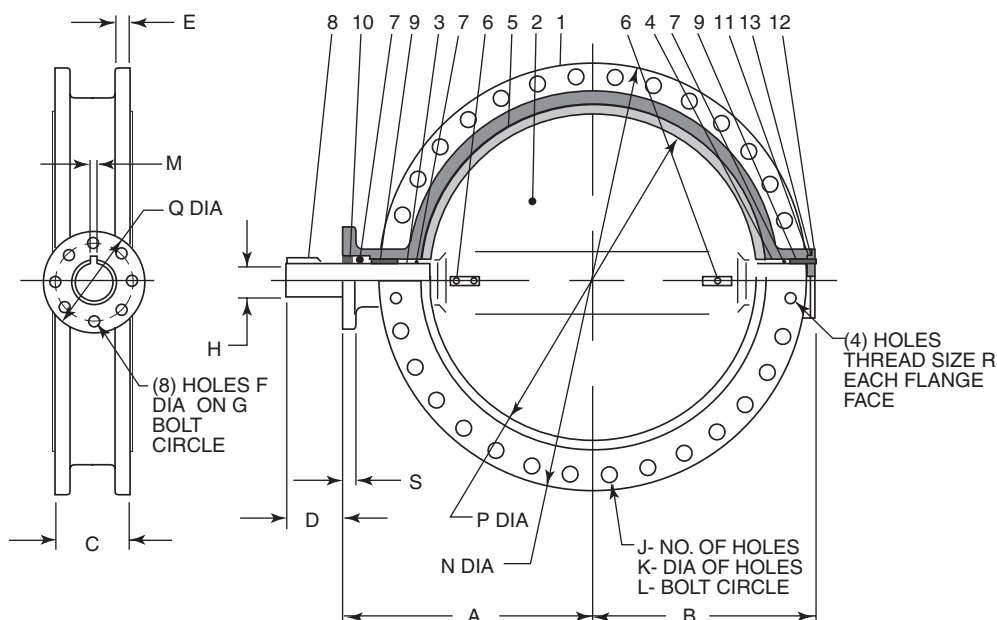

*Dimensions 28" - 48" Double Flanged

	A	B	C	D	E	F	G	H	J	K	L	M	N	P	Q	R	S
28 in	20.8	25	6.6	3.3	2.2	0.7	10	2.5	24	1.4	34.5	0.7 Sq.	37.1	27.8	11.8	1.25 - 7	1.3
mm	520	624	165	85	54	18	254	63.4	24	35	863.4	18 Sq.	927.1	695	300	-	33
30 in	26.4	22.4	6.7	3.4	2.2	0.7	10	2.5	24	1.4	36.6	0.7 Sq.	39.4	29.8	11.8	1.25 - 7	1.1
mm	660	560	167	86	54	18	254	63.4	24	35	914.4	18 Sq.	984	744	300	-	28
32 in	23.6	26.9	7.6	3.3	2.4	0.7	10	2.5	24	1.6	39.1	0.8 Sq.	42.4	31.8	11.8	1.5 - 6	1.3
mm	591	672	190	85	60.3	18	254	63.4	24	41.3	977.9	20 Sq.	1060.4	795	300	-	33
36 in	28.8	25.8	8.1	4.6	2.4	0.7	10	3	28	1.6	43.4	0.8 Sq.	47	34.0	11.8	1.5 - 6	1.3
mm	720	656	203	118	60.3	18	254	75	28	41.3	1085.8	20 Sq.	1169	864.7	300	-	33
40 in	28.8	32	8.7	5.1	2.4	0.7	10	3.3	32	1.6	48	0.9 Sq.	51.6	38.6	11.8	1.5 - 6	1.5
mm	721	800	218	130	60.3	18	254	85	32	41.3	1200.1	22 Sq.	1289	965	300	-	38
42 in	34.3	30.6	10	5.9	2.6	0.7	10	3.3	32	1.6	49.4	0.9 Sq.	53	40.5	11.8	1.5 - 6	1.4
mm	858	777.2	251	150	66	18	254	85	32	41.3	1257.3	22 Sq.	1346	1030	300	-	35
48 in	37.6	34	10.9	5.9	2.8	0.9	11.7	4.1	40	1.6	56	1.1 Sq.	59.5	45.7	13.8	1.5 - 6	1.5
mm	941	864	276.4	150	70	22	298	105	40	41.3	1422.4	28 Sq.	1511	1160	350	-	38

* Please note that dimensions apply to standard product only. For custom/domestic product dimensions, please consult factory.

Weights 2" - 48" - lbs (kg)

	2"	2 1/2"	3"	4"	5"	6"	8"	10"	12"	14"	16"	18"	20"	24"	28"	30"	32"	36"	40"	42"	48"
Wafer	6 (2.7)	7 (3.2)	10 (4.5)	13 (5.9)	18 (8.2)	20 (9.1)	32 (14.5)	42 (19.1)	70 (31.7)	95 (43.1)	117 (53.1)	165 (74.8)	275 (124.7)	440 (199.6)	-	740 (335.7)	-	1660 (754)	-	2145 (975)	3023 (1374)
Lug	7 (3.2)	8 (3.6)	14 (6.4)	26 (11.8)	28 (12.7)	31 (14.1)	49 (22.2)	72 (32.7)	105 (47.6)	155 (70.3)	195 (88.5)	230 (104.3)	396 (179.6)	610 (276.7)	-	1050 (476.3)	-	-	-	-	-
Flanged	-	-	-	-	-	-	-	-	-	-	-	-	-	-	1173 (533)	1173 (533)	1525 (693)	1949 (886)	2141 (973)	2495 (1134)	3711 (1687)

NOTE: TECHNICAL DATA SUBJECT TO CHANGE WITHOUT NOTICE.

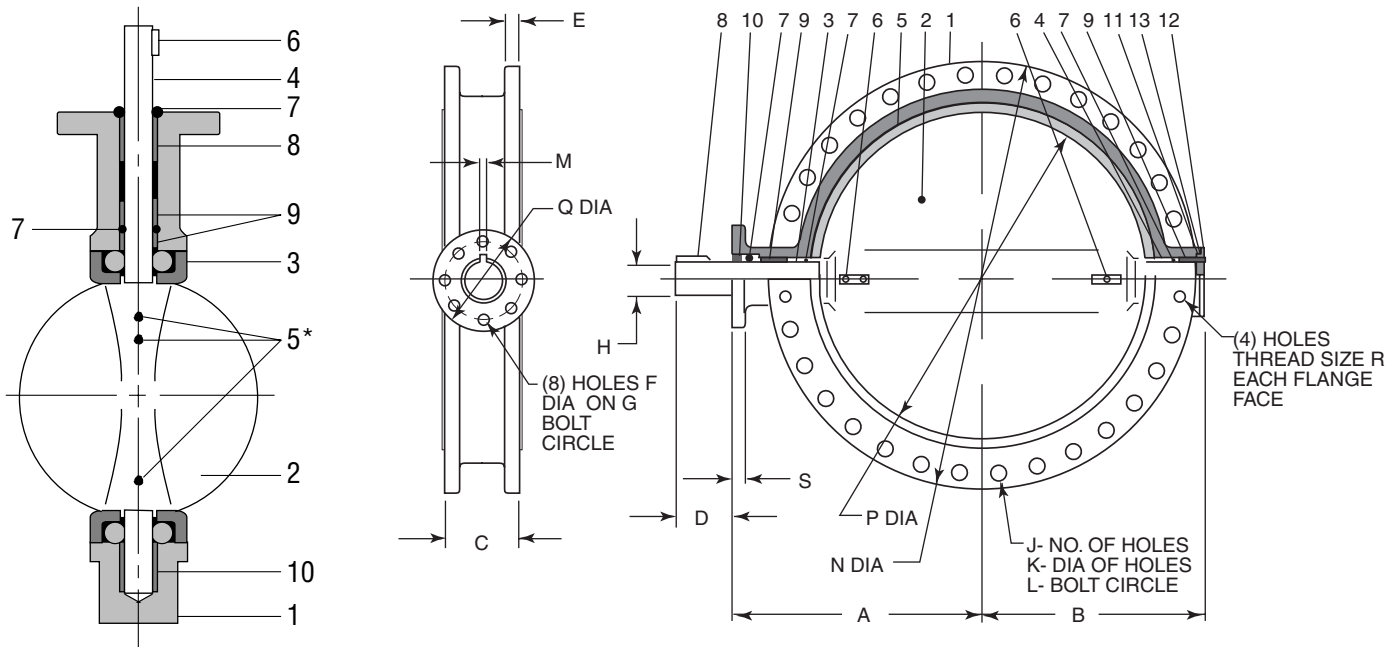

Sizes 2"-30"

*Quantity of 3 pins required for sizes 30" and above

Sizes 36"-48"

Bill of Materials 2" - 30"

Item	Description	Materials	Optional Materials
1	Body	Cast Iron	Ductile Iron
2	Disc	Ductile Iron†	Aluminum Bronze, 316 SS, Monel
3	Seat	Buna-N or EPDM	Neoprene, Hypalon, Viton, PTFE, FDA, Abrasion Resistant
4	Shaft	416 Stainless Steel	316 Stainless Steel, Monel
5	Taper Pin	300 Series Stainless	Monel
6	Key	Carbon Steel	No Option Available
7	O-Ring	Buna-N	No Option Available
8	Bushing	PTFE	Luberized Bronze
9	Bushing	PTFE	Luberized Bronze
10	Bushing	PTFE	Luberized Bronze

†ENP plated for 2"-12" valves

Bill of Materials 36" - 48"

Item	Description	Materials	Optional Materials
1	Body	Ductile Iron	No Option Available
2	Disc	Ductile Iron	Aluminum Bronze, 316 Stainless Steel, Monel
3	Upper Shaft	416 Stainless Steel	316 Stainless Steel, Monel
4	Lower Shaft	416 Stainless Steel	316 Stainless Steel, Monel
5	Seat	Buna-N or EPDM	Hypalon, Viton
6	Taper Pin	300 Series Stainless	Monel
7	O-Ring	Buna-N	No Option Available
8	Key	Carbon Steel	No Option Available
9	Bushing	Luberized Bronze	No Option Available
10	Bushing	Luberized Bronze	No Option Available
11	Thrust Washer	Luberized Bronze	No Option Available
12	End Plate	Ductile	No Option Available
13	O-Ring	Buna-N	No Option Available

- Available in sizes 2" to 24".
- Pressure Rating: 285 psi at 100°F. Pressure/Temperature rating above 100°F corresponds to ASME B16.5 Class 150 for steel flanges.
- Available in Wafer or Lug style body.
- Wafer body features four alignment holes.
- Available in ASME Class 300 Lug Body bolt pattern (2" to 12").
- Ideal for on-off or throttling services.
- Available with handles (2" to 6"), manual gear operators, electric actuators and pneumatic actuators (2" to 24").
- Refer to Crane automation bulletin for details of pneumatic and electric actuators.

- Compatible with ASME B16.1 Class 125 (Iron) and ASME B16.5 Class 150 (Steel) flanges or optional Class 300 (Steel) Lug only.
- Bi-directional dead-end capability to 200 psi (2" to 12") and 150 psi (14" to 24") is an available option.
- Valves 14" and larger are rated at a maximum 150 psi when a companion flange is not used in dead end service.
- For bolting information, consult the Center Line Installation and Maintenance Manual.
- Vacuum Service Rating: zero leakage at 24" of mercury.
- Commercial cleaning available for non-silicone and O₂ service.

Valve Seating Torques (In-Lbs.)

Valve Size	Standard Disc Differential Pressure				
	50 PSI	100 PSI	150 PSI	200 PSI	285 PSI
2"	136	142	148	154	164
2 1/2"	152	160	168	176	189
3"	224	229	234	239	247
4"	380	392	404	416	436
5"	451	477	503	529	572
6"	875	946	1016	1087	1206
8"	1476	1559	1642	1726	1867
10"	2451	2613	2775	2937	3213
12"	3900	4111	4323	4534	4893
14"	5189	5467	5744	6022	6494
16"	10,985	11,569	12,154	12,738	13,732
18"	13,946	14,688	15,431	16,173	17,434
20"	14,695	15,478	16,260	17,043	18,373
24"	29,738	31,321	32,903	34,486	37,176

All torques shown on the chart were derived from test data using water at 60°F. For torques using dry gases, multiply these numbers by 2.0. For torques involving other media, please consult the factory.

There is no safety factor included in the numbers shown on this chart. For actuator sizing, Center Line recommends that these values be multiplied by 1.5 for single valve applications, or 2.0 for 3-way ("tee") applications.

For PTFE seats multiply the numbers shown on this chart by 2.0.

Under certain conditions, hydrodynamic torque can meet or exceed seating and unseating torques. When designing valve systems, hydrodynamic torque must be considered to help assure correct selection for the application.

Seat Temperature Ratings

Material	Temperature Rating °F
Buna-N	+10 to 180
EPDM (2"-16")	-30 to 275
EPDM (18"-24")	-30 to 225
Abrasive Resistant Buna-N	+10 to 180
Neoprene	+20 to 200
Hypalon	0 to 275
Viton	+10 to 275
High Temperature Viton	+10 to 400

Although elastomers have an effective operating temperature range, when used in valves, these ranges may have to be modified. The temperature ranges shown in the table have been adjusted accordingly.

For Low Temperature: While the seat materials selected for use in Center Line butterfly valves are capable of withstanding lower temperatures without damage, the durometer of the elastomer is changed. This "hardening" of the seat may increase the operating torque beyond the structural limits of the stem and/or the disc to stem configuration.

For High Temperature: When using High Temperature Viton, the operating pressure of the valve is reduced above 275°F.

C_v Values – Valve Sizing Coefficients (US-GPM @ 1ΔP)

Size	10°	20°	30°	40°	50°	60°	70°	80°	90°
2"	0.06	3	7	15	27	44	70	105	115
2 1/2"	0.10	6	12	25	45	75	119	178	196
3"	0.20	9	18	39	70	116	183	275	302
4"	0.30	17	36	78	139	230	364	546	600
5"	0.50	29	61	133	237	392	620	930	1022
6"	0.80	34	94	153	257	422	706	1154	1320
8"	2	56	154	251	422	693	1158	1892	2165
10"	3	87	238	385	654	1073	1794	2931	3353
12"	4	153	417	681	1145	1879	3142	5132	5827
14"	6	183	500	816	1372	2252	3765	6150	7037
16"	8	271	740	1208	2031	3333	5573	9104	10,416
18"	11	318	867	1417	2382	3909	6535	10,676	12,215
20"	14	415	1133	1851	3112	5107	8538	13,948	15,959
24"	22	543	1482	2421	4069	6678	11,165	18,240	20,869



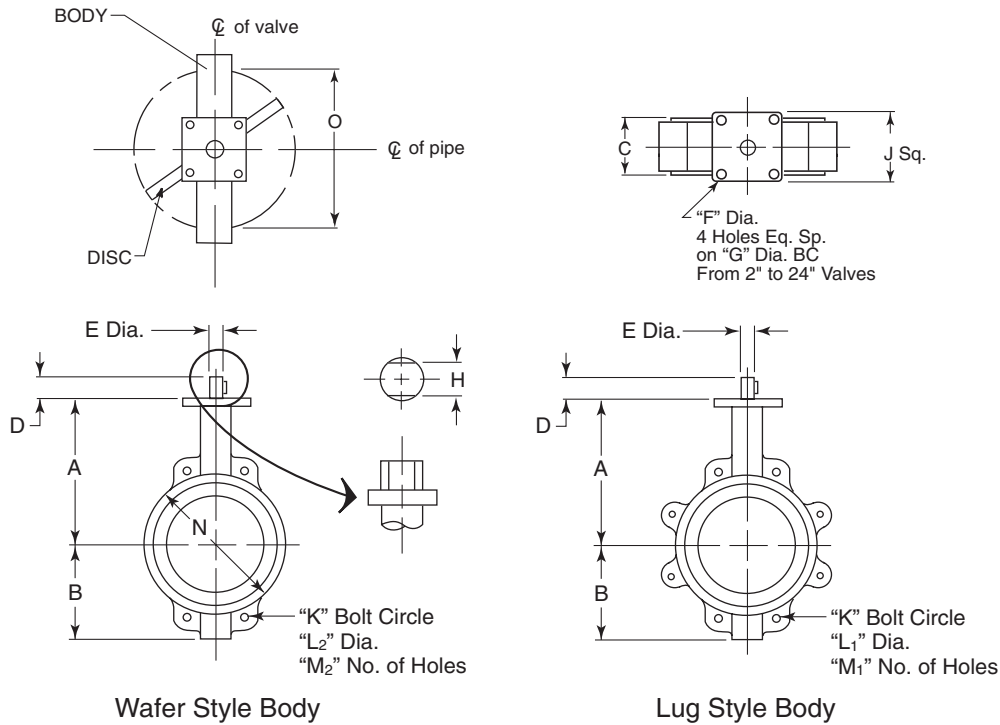

Dimensions and Weights

Valve Size		A	B	C	D	E	F	G	H	J	K	300# K	L ₁	300# L ₁	L ₂	M ₁	300# M ₁	M ₂	WAFER	LUG	300# LUG	O
2" 50	in. mm	6 3/8 161.93	3 1/4 82.55	1 3/4 44.45	1 1/4 31.75	1/2 12.70	3/8 9.53	2.76 70	0.39 10	2 3/4 69.85	4 3/4 120.65	5 127.00	5/8-11	5/8-11	1 1/16 17.46	4	8	4	6 lbs. 2.72 kg	9 lbs. 4.08 kg	9 lbs. 4.08 kg	1.26 32.0
2 1/2" 65	in. mm	6 7/8 174.63	3 3/4 95.25	1 7/8 47.63	1 1/4 31.75	1/2 12.70	3/8 9.53	2.76 70	0.39 10	2 3/4 69.85	5 1/2 139.70	5 7/8 149.23	5/8-11	3/4-10	1 1/16 17.46	4	8	4	7 lbs. 3.18 kg	13 lbs. 5.90 kg	13 lbs. 5.90 kg	1.83 46.5
3" 75	in. mm	7 1/8 180.98	4 101.60	1 7/8 47.63	1 1/4 31.75	1/2 12.70	3/8 9.53	2.76 70	0.39 10	2 3/4 69.85	6 152.40	6 5/8 168.28	5/8-11	3/4-10	1 1/16 17.46	4	8	4	10 lbs. 4.54 kg	14 lbs. 6.35 kg	14 lbs. 6.35 kg	2.54 64.5
4" 100	in. mm	7 7/8 200.03	4 7/8 123.83	2 1/8 53.98	1 1/4 31.75	5/8 15.88	3/8 9.53	2.76 70	0.47 12	2 3/4 69.85	7 1/2 190.50	7 7/8 200.03	5/8-11	3/4-10	1 1/16 17.46	8	8	4	13 lbs. 5.90 kg	19 lbs. 8.62 kg	24 lbs. 10.89 kg	3.54 89.9
5" 125	in. mm	8 3/8 212.73	5 3/8 136.53	2 1/4 57.15	1 1/4 31.75	3/4 19.05	3/8 9.53	2.76 70	0.55 14	2 3/4 69.85	8 1/2 215.90	9 1/4 234.95	5/8-11	3/4-10	1 3/16 20.64	8	8	4	18 lbs. 8.16 kg	22 lbs. 9.98 kg	29 lbs. 13.15 kg	4.36 110.7
6" 150	in. mm	8 7/8 225.43	5 7/8 149.23	2 1/4 57.15	1 1/4 31.75	3/4 19.05	3/8 9.53	2.76 70	0.55 17	2 3/4 69.85	9 1/2 241.30	10 5/8 269.88	5/8-11	3/4-10	1 3/16 20.64	8	12	4	21 lbs. 9.53 kg	31 lbs. 14.06 kg	38 lbs. 17.24 kg	5.74 145.8
8" 200	in. mm	10 1/4 260.35	7 3/4 196.85	2 1/2 63.50	1 3/4 44.45	7/8 22.23	7/16 11.11	4.02 102	0.67 17	3 3/4 95.33	11 3/4 298.45	13 330.20	3/4-10	7/8-9	1 3/16 20.64	8	12	4	34 lbs. 15.42 kg	49 lbs. 22.23 kg	67 lbs. 30.39 kg	7.63 193.8
10" 250	in. mm	11 1/2 292.10	8 1/4 209.55	2 3/4 69.85	1 3/4 44.45	1 1/8 28.58	7/16 11.11	4.02 102	0.87 22	3 3/4 95.33	14 1/4 361.95	15 1/4 387.35	7/8-9	1-8	1 5/16 23.81	12	16	4	45 lbs. 20.41 kg	62 lbs. 28.12 kg	100 lbs. 45.36 kg	9.54 242.3
12" 300	in. mm	13 1/4 336.55	9 3/4 247.65	3 1/8 79.38	1 3/4 44.45	1 1/4 31.75	7/16 11.11	4.02 102	0.95 24	3 3/4 95.33	17 431.80	17 3/4 450.85	7/8-9	1 1/8-7	1 5/16 23.81	12	16	4	74 lbs. 33.57 kg	105 lbs. 47.63 kg	144 lbs. 65.32 kg	11.5 292.1
14" 350	in. mm	14 1/2 368.30	11 279.40	3 1/8 79.38	1 3/4 44.45	1 1/4 31.75	7/16 11.11	4.20 102	0.95 24	3 3/4 95.33	18 3/4 476.25	-	1-8	-	1 1/16 26.99	12	-	4	109 lbs. 49.44 kg	178 lbs. 80.74 kg	-	12.81 325.4
16" 400	in. mm	15 3/4 400.05	12 304.80	3 1/2 88.90	2 50.80	1 5/16 33.34	7/8 22.23	6.50 165	1.06 27	6 1/2 165.10	21 1/4 539.75	-	1-8	-	1 1/16 26.99	16	-	4	135 lbs. 61.24 kg	224 lbs. 101.60 kg	-	15 381.0
18" 450	in. mm	16 5/8 422.28	15 381.00	4 1/4 107.95	2 50.80	1 5/8 41.28	7/8 22.23	6.50 165	1.26 32	6 1/2 165.10	22 3/4 577.85	-	1 1/8-7	-	1 3/16 30.16	16	-	4	190 lbs. 86.18 kg	265 lbs. 120.20 kg	-	16.87 428.5
20" 500	in. mm	18 7/8 479.43	15 381.00	5 1/4 133.35	2 1/2 63.50	1 5/8 41.28	7/8 22.23	6.50 165	1.26 32	6 1/2 165.10	25 635.00	-	1 1/8-7	-	63/64 25.00	20	-	4	316 lbs. 143.34 kg	455 lbs. 206.38 kg	-	18.69 474.7
24" 600	in. mm	22 1/8 561.98	18 457.20	6 1/8 155.58	2 3/4 69.85	3 76.20	7/8 22.23	6.50 165	2.36 60	6 1/2 165.10	29 1/2 749.30	-	1 1/8-7	-	1 1/4 28.18	20	-	4	506 lbs. 229.52 kg	702 lbs. 318.42 kg	-	22.57 573.3

NOTE: 20" Wafer: L₂ dia. Hole is Tapped w/1-1/8-7 on Each Side

24" Wafer: L₂ dia. Hole is Tapped w/1-1/4-7 on Each Side

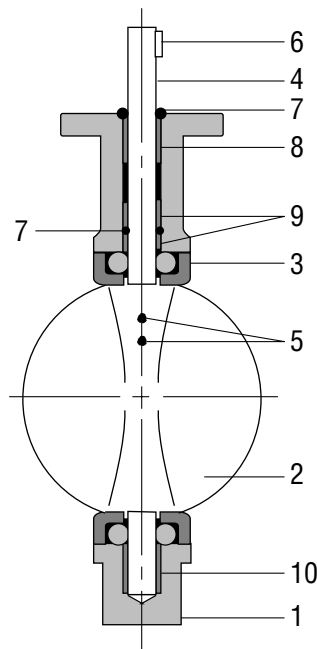

Bill of Materials (Series 225)

Item	Description	Materials	Optional Materials
1	Body	Ductile Iron	No Options Available
2	Disc	Ductile Iron [†]	Aluminum Bronze, 316 Stainless Steel, Monel
3	Seat	Buna-N or EPDM	Neoprene, Hypalon, Abrasive Resistant Buna-N, Low Temperature Viton, High Temperature Viton
4	Shaft	416 Stainless Steel	2"-12": 17-4 PH, Monel
5	Taper Pin	300 Series Stainless	Monel
6	Key	Carbon Steel	No Option Available
7	O-Ring	Buna-N	No Option Available
8	Bushing	PTFE	No Option Available
9	Bushing	PTFE	No Option Available
10	Bushing	PTFE	No Option Available

[†]ENP plated for 2" - 12" valves

Bill of Materials (Series 250)

Item	Description	Materials	Optional Materials
1	Body	Carbon Steel A216 GR.WCB	316SS A351 GR.CF8M
2	Disc	316 Stainless	Aluminum Bronze, Monel
3	Seat	Buna-N or EPDM	Neoprene, Hypalon, Abrasion Resistant Buna-N, Low Temperature Viton, High Temperature Viton
4	Shaft	316 Stainless Steel	17-4 PH, Monel
5	Taper Pin	300 Series Stainless	Monel
6	Key	Carbon Steel	No Option Available
7	O-Ring	Buna-N	No Option Available
8, 9, 10	Bushing	PTFE	No Option Available

The Center Line Series 300 butterfly valve provides a clean internal profile to ensure sanitary processing of line media. A typical application is as an internal drive valve for the chemical, pharmaceutical, and food and beverage markets.

Mounting Flange:

ISO 5211 mounting flange accommodates direct mounting of all types of actuators, including: handles, gear operators, electric and pneumatic.

O-Ring:

Tertiary stem seal provides further assurance against stem leakage.

Hub Seal:

Smooth finished disc flats mate with seat flats to give a highly efficient primary seal that prevents leakage into the shaft area and minimizes torque.

Disc:

Precision profile provides bubble-tight shut-off, assures minimum torque and longer seat life. Maximum flow is achieved by eliminating the "through shaft" and external disc fasteners.

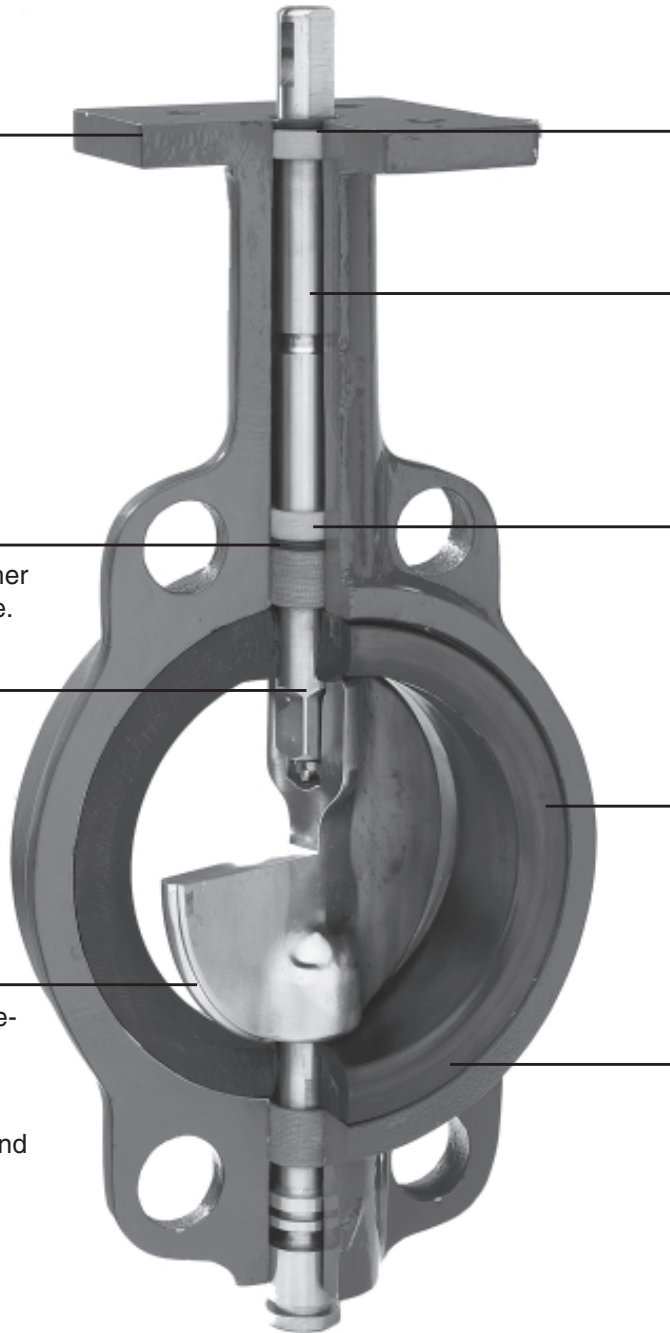

Weather Seal:

O-ring seals keep dust and moisture from entering the upper stem journal.

Stem:

Stub shaft design allows the disc to float within the flow-way increasing cycle life.

Bushings (4):

Stem bushings reduce torque and isolate the stem from the valve body, preventing seizure of the stem due to corrosion in the stem journal.

Seat Face:

Seat to flange seal eliminates the need for flange gaskets.

Seat:

Phenolic-backed seat is non-collapsible, stretch resistant, blow out proof, and field replaceable.

- Available in sizes 2" to 12".
- Available in Wafer or Lug style body.
- Wafer body features four alignment holes.
- Pressure ratings for tight shut-off at temperatures up to the maximum limit of the seat material:
2" to 12" — 200 psi, 125 psi for PTFE seat.
- Ideal for on-off or throttling services.
- Available with handles, manual gear operators, pneumatic, or electric actuators.
- Refer to Crane actuator bulletin for details of pneumatic and electric actuators.
- Designed to comply with MSS SP-67 and API 609. For valve dimensions, see table on page 6.
- Compatible with ASME 125/150 flanges.
- Bi-directional dead-end capability to 200 psi available.
- Operators mounted perpendicular to pipe.
- Commercial cleaning available for non-silicone and O₂ service.

Valve Seating Torques (In-Lbs.)

Valve Size	Standard Disc Differential Pressure				Undercut Diff. Press.
	50 PSI ΔP	100 PSI ΔP	150 PSI ΔP	200 PSI ΔP	75 PSI ΔP
2"	100	106	111	117	-
2 1/2"	150	163	176	189	-
3"	207	220	232	244	-
4"	290	323	357	390	-
5"	423	481	540	598	-
6"	599	691	783	875	-
8"	1,060	1,183	1,307	1,430	819
10"	1,671	1,872	2,074	2,275	909
12"	2,568	2,795	3,023	3,250	1,445

All torques shown on the chart were derived from test data using water at 60°F. For torques using dry gases, multiply these numbers by 2.0. For torques involving other media, please consult the factory.

There is no safety factor included in the numbers shown on this chart. For actuator sizing, Center Line recommends that these values be multiplied by 1.5 for single valve applications, and 2.0 for 3-way ("tee") applications.

Under certain conditions, hydrodynamic torque can meet or exceed seating and unseating torques. When designing valve systems, hydrodynamic torque must be considered to help assure correct selection for the application.

Seat Temperature Ratings

Material	Temperature Ratings °F
Buna-N	+10 to 180
Abrasive Resistant Buna-N	+10 to 180
Neoprene	+20 to 200
EPDM	-30 to 275
EPDM (18" & Above)	-30 to 225
EPDM, Food Grade	-30 to 225
Hypalon	0 to 275
Viton	+10 to 275
High Temperature Viton	+10 to 400
PTFE over Buna-N	+40 to 275

Notes:

- Although elastomers have an effective operating temperature range, when used in valves these ranges may have to be modified. The temperature ranges shown in the table have been adjusted accordingly.
- **For Low Temperature:** While the seat materials selected for use in Center Line butterfly valves are capable of withstanding lower temperatures without damage, the durometer of the elastomer is changed. This “hardening” of the seat can increase the operating torque beyond the structural limits of the stem and/or the disc to stem connection.
- **For High Temperature:** When using High Temperature Viton, the operating pressure of the valve is reduced above 275°F.

C_v Values – based on water @70°F with a Specific Gravity of 1.

Size	Disc Position							
	20°	30°	40°	50°	60°	70°	80°	90°
2"	3	7	19	36	63	84	115	120
2 1/2"	4	10	24	47	78	113	182	194
3"	14	21	45	84	133	203	382	430
4"	30	52	100	165	270	420	703	830
5"	85	130	210	345	525	825	1350	1500
6"	165	225	360	570	820	1260	1875	1980
8"	210	300	480	780	320	2280	3780	3870
10"	405	575	850	1200	1900	3300	6100	6450
12"	550	750	1200	1875	2850	5025	9300	9800

Rate of flow through a valve depends upon the pressure drop. The most common method of presenting this information is by C_v. The C_v is the “valve coefficient of flow” and represents the flow of water in gallons per minute (GPM) with a 1 PSI pressure drop through the valve. The higher the C_v, the greater the flow and the better the control characteristics.

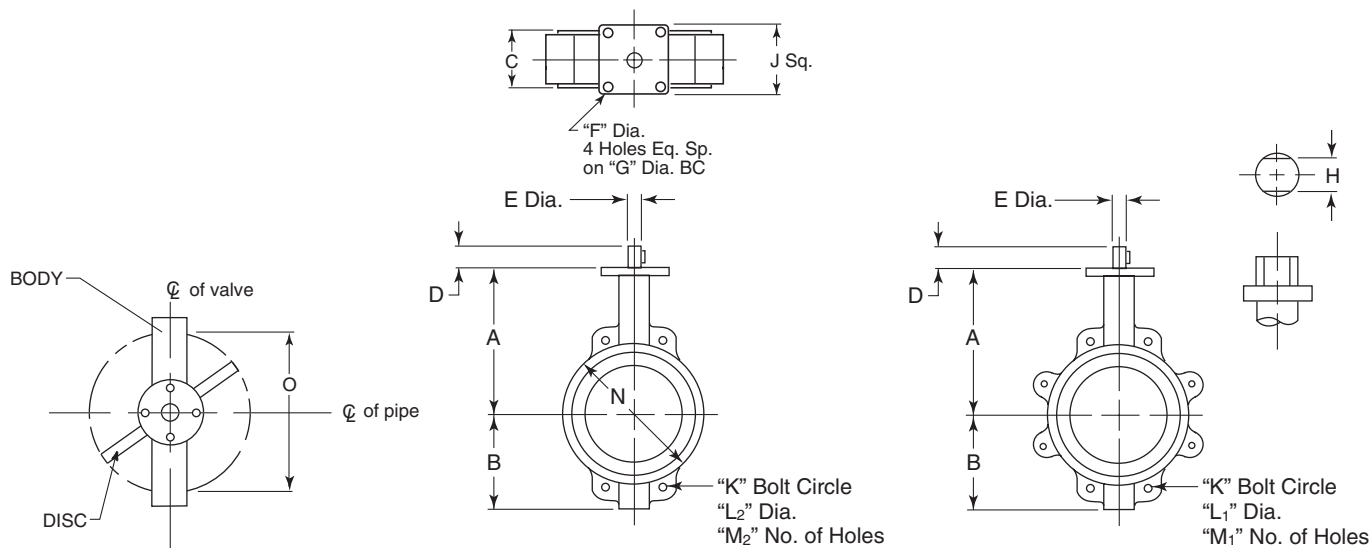

Dimensions

VALVE SIZE		A	B	C	D	E	F	G	H	J	K	L ₁	L ₂	M ₁	M ₂	N	O
2"	in.	6 3/8	3 1/4	1 3/4	1 1/4	1/2	3/8	2.76	0.39	2 3/4	4 3/4	5/8-11	1 1/16	4	4	4.	1.26
50	mm	161.93	82.55	44.45	31.75	12.70	9.53	70	10	69.85	120.65					101.60	32.0
2 1/2"	in.	6 7/8	3 3/4	1 7/8	1 1/4	1/2	3/8	2.76	0.39	2 3/4	5 1/2	5/8-11	1 1/16	4	4	4 3/4	1.83
65	mm	174.63	95.25	47.63	31.75	12.70	9.53	70	10	69.85	139.70	17.46				120.65	46.5
3"	in.	7 1/8	4	1 7/8	1 1/4	1/2	3/8	2.76	0.39	2 3/4	6	5/8-11	1 1/16	4	4	5 1/8	2.54
75	mm	180.98	101.60	47.63	31.75	12.70	9.53	70	10	69.85	152.40	17.46				130.18	64.5
4"	in.	7 7/8	4 7/8	2 1/8	1 1/4	5/8	3/8	2.76	0.47	2 3/4	7 1/2	5/8-11	1 1/16	8	4	6 3/4	3.54
100	mm	200.03	123.83	53.98	31.75	15.88	9.53	70	12	69.85	190.50	17.46				171.45	89.9
5"	in.	8 3/8	5 3/8	2 1/4	1 3/4	3/4	3/8	2.76	0.55	2 3/4	8 1/2	3/4-10	1 3/16	8	4	7 3/4	4.36
125	mm	212.73	136.53	57.15	20.64	19.05	9.53	70	14	69.85	215.90	20.64				196.85	110.7
6"	in.	8 7/8	5 7/8	2 1/4	1 3/4	3/4	3/8	2.76	0.55	2 3/4	9 1/2	3/4-10	1 3/16	8	4	8 3/8	5.72
150	mm	225.43	149.23	57.15	31.75	19.05	9.53	70	14	69.85	241.30	20.64				219.08	145.3
8"	in.	10 1/4	7 1/8	2 1/2	1 3/4	7/8	7/16	4.02	0.67	3 3/4	11 3/4	3/4-10	1 3/16	8	4	10 5/16	7.6
200	mm	260.35	180.98	63.50	44.45	22.23	11.11	102	17	95.33	298.45	20.64				268.29	193.0
10"	in.	11 1/2	8 1/4	2 3/4	1 3/4	1 1/8	7/16	4.02	0.87	3 3/4	14 1/4	7/8-9	1 5/16	12	4	13 1/16	9.5
250	mm	292.10	209.55	69.85	44.45	28.58	11.11	102	22	95.33	361.95	23.81				331.79	241.3
12"	in.	13 1/4	9 3/4	3 1/8	1 3/4	1 1/4	7/16	4.02	0.95	3 3/4	17	7/8-9	1 5/16	12	4	16 1/8	11.45
300	mm	336.55	247.65	79.38	44.45	31.75	11.11	102	24	95.33	431.80	23.81				409.58	290.8

Weights

Valve Configuration		Size								
		2	2 1/2	3	4	5	6	8	10	12
Wafer	Lbs.	6	7	10	13	18	20	32	42	70
	Kg.	2.72	3.18	4.54	5.90	8.16	9.07	14.51	19.05	31.75
Lug	Lbs.	7	8	14	26	28	31	49	72	105
	Kg.	3.18	3.63	6.35	11.79	12.70	14.06	22.23	32.66	47.63

- "L₁" and "M₁" refer to Lug style valves, "L₂" and "M₂" refer to Wafer Style.
- "C" dimension is listed with elastomer in the relaxed condition. Approximately 1/8" total compression is required for proper sealing with pipe flanges.
- Valves are designed for installation between ASME B16.1 Class 125 (Iron) and B16.5 Class 150 (Steel) flanges. Gaskets are not needed, and should not be used since the seat face seals against the mating flange.
- If the valve is to be installed between plastic or fiberglass flanges, flange rings, or Van Stone style flanges, consult your Center Line agent or the factory for additional information.
- Center Line recommends that a blind flange be used on end of line applications.
- "O" dimension is disc chord dimension.
- Consult factory for dimension to 2 1/2" and 5" PTFE seated valves.

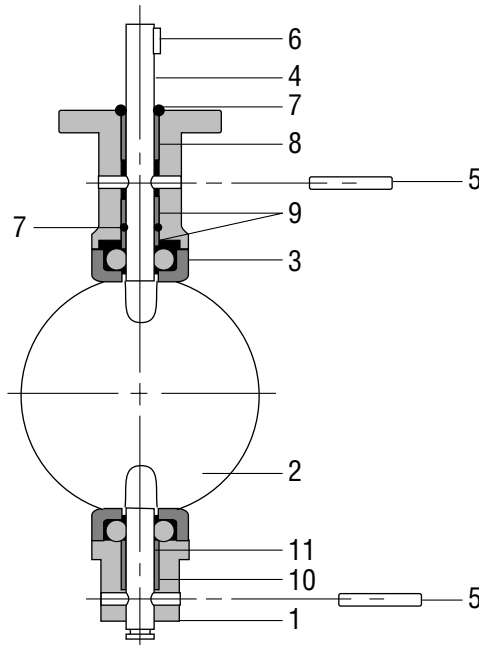

Bill of Materials

Item	Description	Materials	Optional Materials
1	Body	Cast Iron	Ductile Iron
2	Disc	Ductile Iron [†]	Aluminum Bronze, 316 Stainless Steel, Monel
3	Seat	Buna-N or EPDM	Neoprene, Hypalon, Viton, PTFE
4	Upper Shaft	416 Stainless Steel	316 Stainless Steel, Monel
5	Retaining Pin	Carbon Steel	316 Stainless Steel
6	Key	Carbon Steel	No Option Available
7	O-Ring	Buna-N	No Option Available
8	Bushing	PTFE	Luberized Bronze
9	Bushing	PTFE	Luberized Bronze
10	Bushing	PTFE	Luberized Bronze
11	Lower Shaft	416 Stainless Steel	316 Stainless Steel, Monel

[†]ENP plated for 2" - 12" valves

Features and Benefits

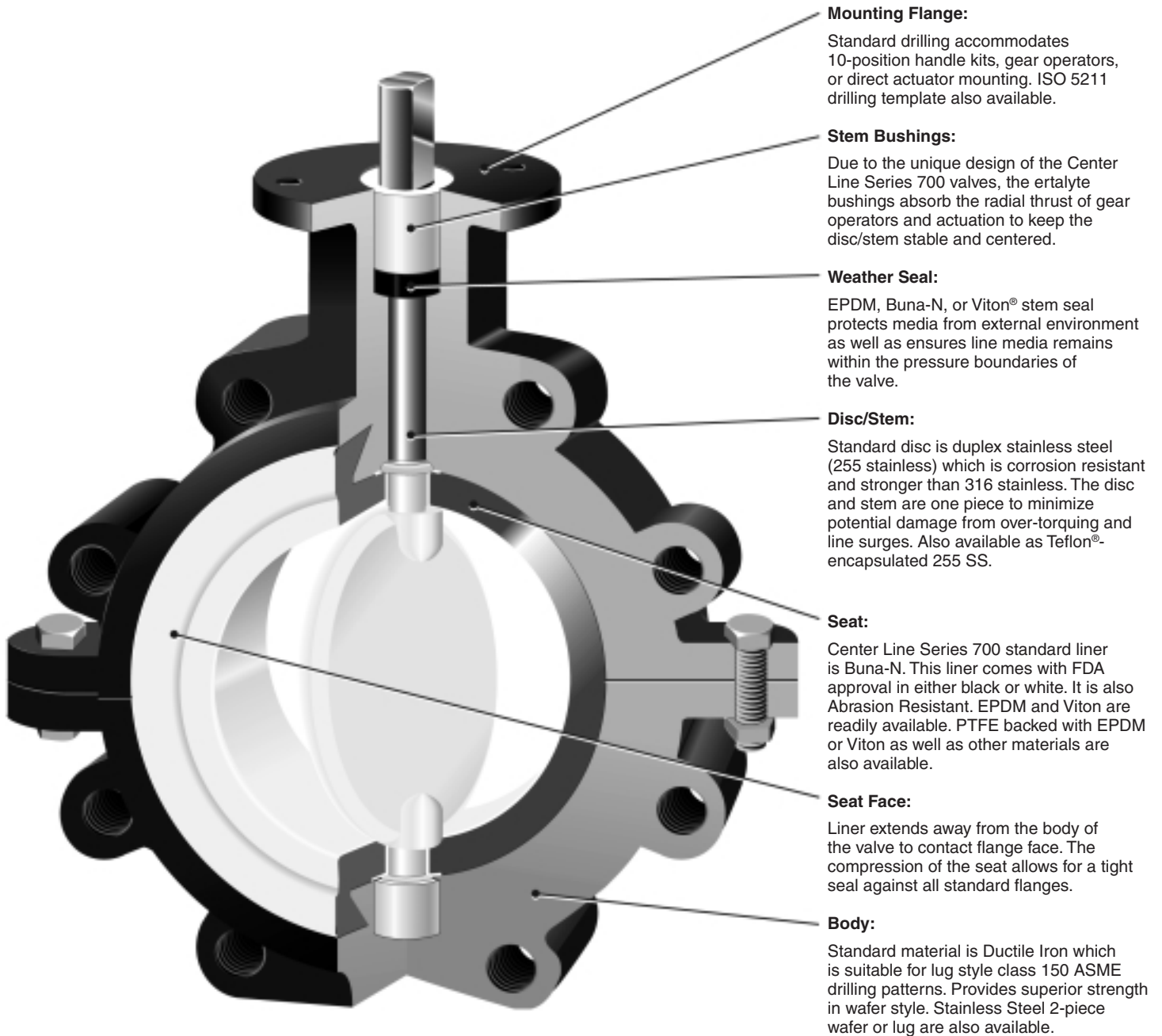

Mounting Flange:

Standard drilling accommodates 10-position handle kits, gear operators, or direct actuator mounting. ISO 5211 drilling template also available.

Stem Bushings:

Due to the unique design of the Center Line Series 700 valves, the ertalyte bushings absorb the radial thrust of gear operators and actuation to keep the disc/stem stable and centered.

Weather Seal:

EPDM, Buna-N, or Viton® stem seal protects media from external environment as well as ensures line media remains within the pressure boundaries of the valve.

Disc/Stem:

Standard disc is duplex stainless steel (255 stainless) which is corrosion resistant and stronger than 316 stainless. The disc and stem are one piece to minimize potential damage from over-torquing and line surges. Also available as Teflon®-encapsulated 255 SS.

Seat:

Center Line Series 700 standard liner is Buna-N. This liner comes with FDA approval in either black or white. It is also Abrasion Resistant. EPDM and Viton are readily available. PTFE backed with EPDM or Viton as well as other materials are also available.

Seat Face:

Liner extends away from the body of the valve to contact flange face. The compression of the seat allows for a tight seal against all standard flanges.

Body:

Standard material is Ductile Iron which is suitable for lug style class 150 ASME drilling patterns. Provides superior strength in wafer style. Stainless Steel 2-piece wafer or lug are also available.

Teflon® and Viton® are registered trademarks of E.I. DuPont Co.

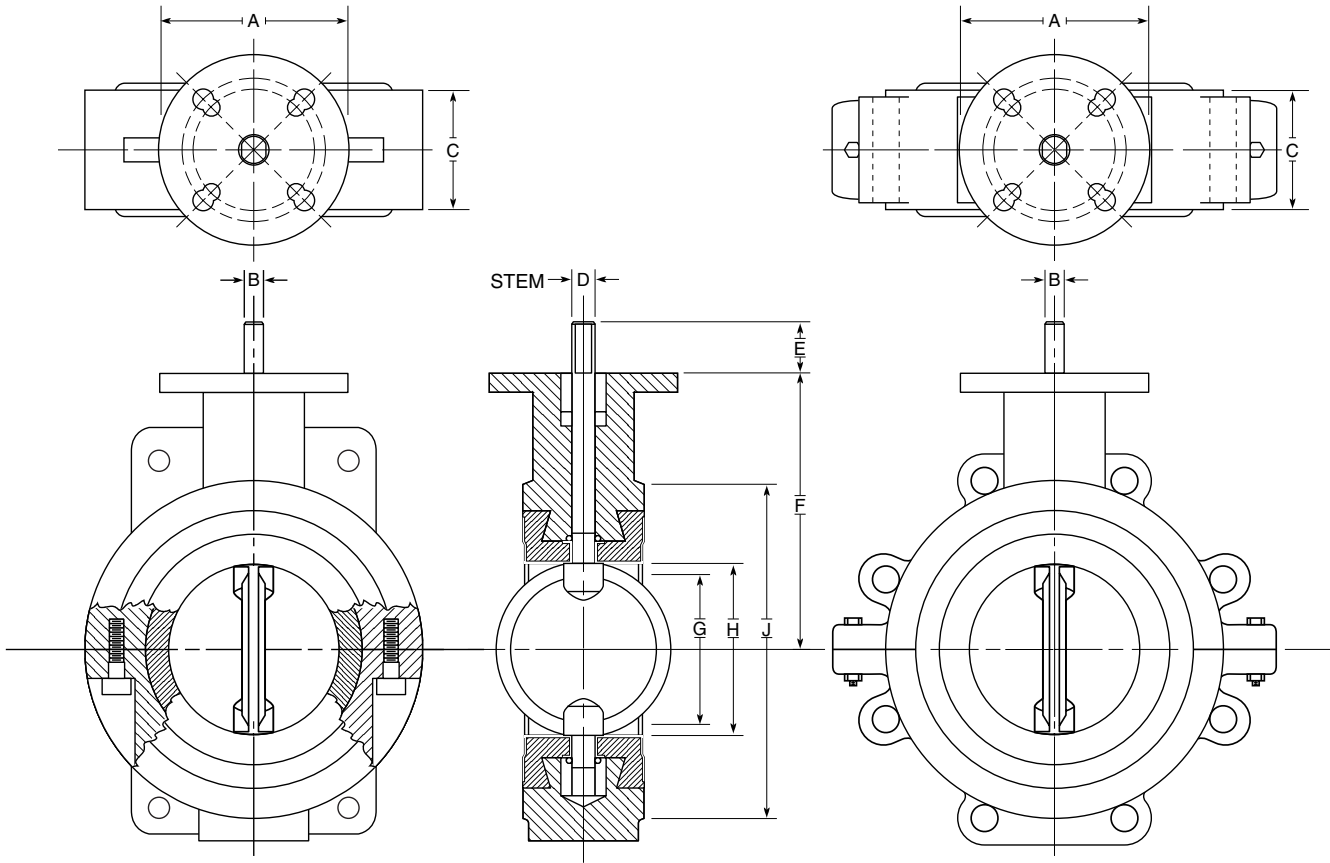

Dimensions

	1	1.5	2	2.5	3	4	5	6	8	10	12
A	2.560	2.560	4.000	4.000	4.000	4.000	4.000	4.000	6.000	6.000	6.000
B	.250	.250	.375	.375	.375	.438	.500	.500	.625	—	—
C	1.125	1.188	1.625	1.750	1.750	2.000	2.125	2.125	2.500	2.500	3.000
D	.375	.375	.563	.563	.563	.625	.750	.750	.875	1.125	1.125
E	.750	.750	1.250	1.250	1.250	1.250	1.250	1.250	1.250	2.000	2.000
F	3.540	4.120	3.938	4.500	4.875	6.000	6.000	6.500	8.313	9.000	10.625
G	.625	1.438	1.375	2.063	2.563	3.625	4.750	5.500	7.500	9.594	11.563
H	1.188	1.750	2.000	2.500	3.000	4.000	5.000	5.750	7.750	9.750	11.750
J	2.437	3.218	4.125	4.825	5.250	6.750	7.625	8.625	10.812	13.375	16.188

"C" IS INSTALLED WIDTH • "G" IS MIN. ALLOWABLE INSIDE DIA. OF PIPE OR MATING FLANGE
 1"-8" — "D" IS STEM CONNECTION DIA.; "B" IS FLATS • 10" - 12" — "D" IS STEM CONNECTION DIA.; KEYWAY IS .250 X .250

Top Plate Drilling Pattern

	1	1.5	2	2.5	3	4	5	6	8	10	12
No. Holes	N/A	N/A	4	4	4	4	4	4	4	4	4
Bolt Circle	—	—	3.250	3.250	3.250	3.250	3.250	3.250	5.000	5.000	5.000
Hole Dia.	—	—	.438	.438	.438	.438	.438	.438	.563	.563	.563

ISO	1	1.5	2	2.5	3	4	5	6	8	10	12
No. Holes	4	4	4	4	4	4	4	4	4	4	4
Bolt Circle	1.970	1.970	2.760	2.760	2.760	2.760	2.760	2.760	4.020	4.020	4.020
Hole Dia.	.281	.281	.375	.375	.375	.375	.375	.375	.406	.406	.406

Standard and ISO drilling come on each valve

VELOCITY LIMITS - FOR ON/OFF SERVICES
 FLUIDS - 9 M/S (30 FT/SEC) GASES - 54 M/S (175 FT/SEC)

Weight*

	1	1.5	2	2.5	3	4	5	6	8	10	12
Water	2	4	6	8	9	11	15	17	29	44	85
Lug	N/A	N/A	8	10	11	17	21	26	42	65	108

*Based on 255 Stainless Steel disc/stem and Cast Iron Body.

Bolt Circle and Tapped Lug

	1	1.5	2	2.5	3	4	5	6	8	10	12
Bolt Circle	3.125	3.875	4.750	5.500	6.000	7.500	8.500	9.500	11.750	14.250	17.000
No. Holes	4	4	4	4	4	8	8	8	8	12	12
Tap	N/A		.625-11 UNC				.750-10 UNC		.875-9 UNC		

If you want cost-effective backflow protection for your piping systems, look at what the Series 800 from Center Line has to offer. It's the only fully elastomer-lined insert check valve available. The ductile iron valve body is completely isolated from line media which can extend the service life of the Series 800 in most applications and makes it an especially economical alternative in applications which would otherwise require check valves made of expensive alloys.

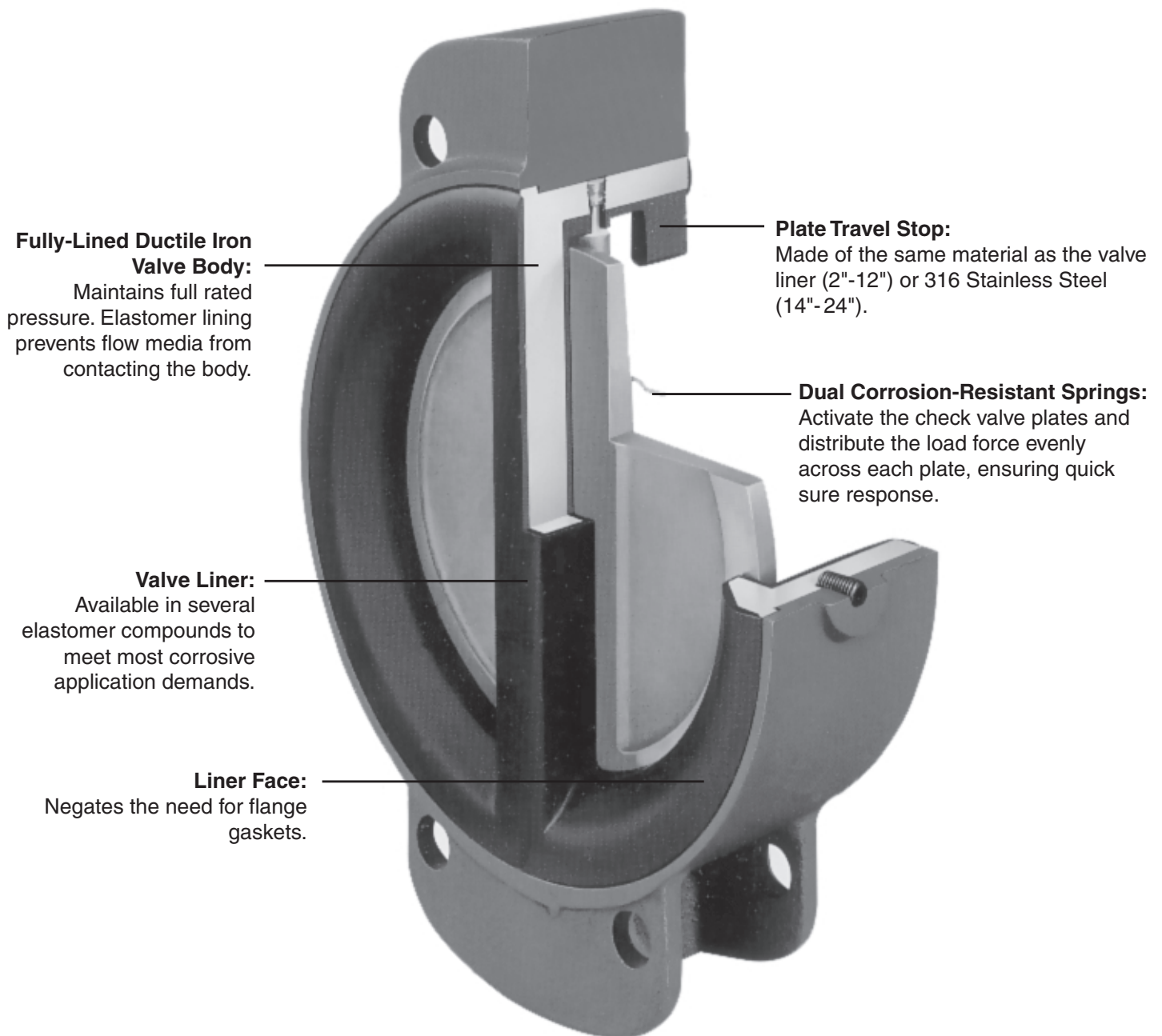

- Available in sizes 2" to 24".
- Only fully elastomer lined check valve available.
- Bubble-tight shutoff from 25 to 150 psi ΔP . Lower minimum pressure available on request.
- Wide range of available elastomers; Buna-N or EPDM standard.
- Check valves compatible with ASME B16.1, Class 125 (Iron) or B16.5, Class 150 (Steel) flanges.
- Use of dual springs distributes the load force evenly across each plate, resulting in quick response to flow reversal.
- Commercial cleaning available for non-silicone and O₂ service.

Liner Temperature Ratings

Material	Temperature Ratings °F
Buna-N (Standard)	+10 to 180
EPDM (Standard)	-30 to 275
Neoprene	+20 to 200
Viton	+10 to 400
Hypalon	0 to 275

Some flow media may further restrict the published temperature limits and/or significantly reduce seat life. Consult factory for additional information.

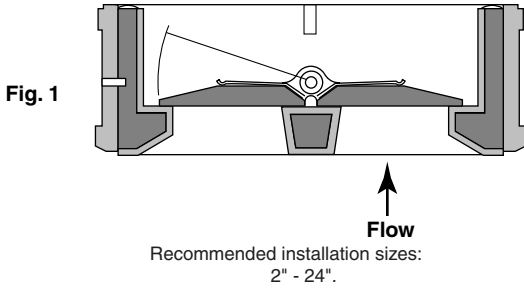

Fig. 2

Flow →

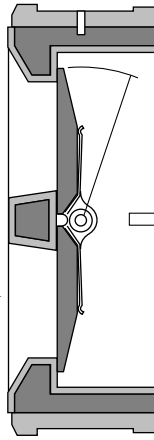
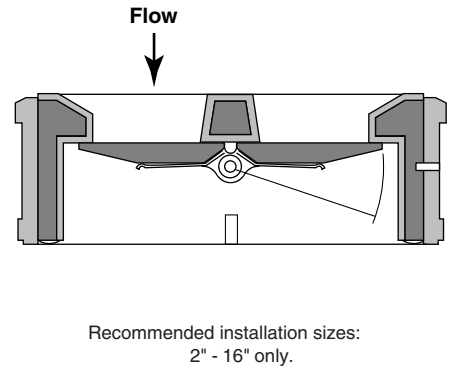

Fig. 3



Note: Valve should be installed with shaft in the vertical position in a horizontal pipe. This view rotated 90° for pictorial clarity.

C_v Values – Valve Sizing Coefficients (US-GPM @ 1ΔP)

Valve Size	C _v	Cracking Pressure To Open Valve (Inches of Water Column)*		
		Figure 1	Figure 2	Figure 3
2"	36	14	10	5
2 1/2"	62	18	12	6
3"	123	11	7	2
4"	281	10	6	2
5"	522	14	10	6
6"	1033	12	8	5
8"	2158	12	9	5
10"	3368	14	13	8
12"	5068	15	10	6
14"	6465	20	12	6
16"	9172	20	12	6
18"	12,853	16	10	—
20"	17,398	24	16	—
24"	28,794	22	15	—

*Figures are approximate. 1" of water column = .036 psi.

Dimensions [in (mm)] and Weights [lbs (kg)]

Valve Size	A	B	C	D	E	F	G	H	J	K	Weight
2 (50)	6.25 (158.75)	4.00 (101.60)	3.31 (84.14)	2.62 (66.68)	2.06 (52.39)	4.75 (120.65)	0.69 (17.46)	1.12 (47.63)	1.88 (47.63)	2.12 (53.98)	5 (2.27)
2 1/2 (65)	7.00 (177.80)	4.75 (120.65)	3.88 (98.43)	3.12 (79.38)	2.06 (52.39)	5.50 (139.70)	0.69 (17.46)	1.44 (36.51)	2.31 (58.74)	2.12 (53.98)	6 (2.72)
3 (80)	7.50 (190.50)	5.25 (133.35)	4.56 (115.89)	3.62 (92.08)	2.06 (52.39)	6.00 (152.40)	0.69 (17.46)	1.62 (41.28)	2.75 (69.85)	2.12 (53.98)	8 (3.63)
4 (100)	9.25 (234.95)	6.75 (171.45)	5.62 (142.88)	4.62 (117.48)	2.44 (61.91)	7.50 (190.50)	0.69 (17.46)	2.12 (53.98)	3.44 (87.31)	2.50 (63.50)	15 (6.81)
5 (125)	10.62 (269.88)	7.62 (193.68)	6.75 (171.45)	5.69 (144.46)	2.56 (65.03)	8.50 (215.90)	0.81 (20.64)	2.66 (67.47)	4.44 (112.71)	2.62 (66.68)	20 (9.08)
6 (150)	12.00 (304.80)	8.75 (222.25)	7.88 (200.03)	6.75 (171.45)	3.06 (77.79)	9.50 (241.30)	0.81 (20.64)	3.16 (80.17)	5.56 (141.29)	3.12 (79.38)	26 (11.80)
8 (200)	14.50 (368.30)	10.62 (269.88)	10.00 (254.00)	8.75 (222.25)	3.81 (96.84)	11.75 (298.45)	0.81 (20.64)	4.16 (105.57)	7.56 (192.09)	3.88 (98.43)	43 (19.52)
10 (250)	16.88 (428.63)	13.25 (336.55)	12.12 (307.98)	10.88 (276.23)	3.94 (100.01)	14.25 (361.95)	0.94 (23.81)	5.12 (130.18)	9.06 (230.19)	4.00 (101.60)	58 (26.33)
12 (300)	19.450 (495.30)	16.00 (406.40)	14.38 (365.13)	12.88 (327.03)	5.06 (128.59)	17.00 (431.80)	0.94 (23.81)	6.25 (158.75)	10.81 (274.64)	5.12 (130.18)	100 (45.40)
14 (350)	22.50 (571.50)	17.62 (447.68)	15.62 (396.88)	14.12 (358.78)	7.00 (177.80)	18.75 (476.25)	1.06 (26.99)	6.75 (171.45)	12.06 (306.39)	7.12 (180.98)	135 (61.29)
16 (400)	24.88 (631.83)	20.12 (511.18)	17.75 (450.85)	16.12 (409.58)	8.25 (212.72)	21.25 (539.75)	1.06 (26.99)	7.75 (196.85)	14.00 (355.60)	6.38 (161.93)	170 (77.18)
18 (450)	25.25 (641.35)	21.50 (546.10)	20.00 (508.00)	18.12 (460.37)	7.12 (180.97)	22.75 (577.85)	1.19 (30.16)	8.75 (222.25)	16.00 (406.14)	7.25 (184.15)	220 (99.88)
20 (500)	27.50 (698.50)	23.50 (596.90)	21.88 (555.62)	20.12 (511.17)	8.38 (212.72)	25.00 (635.00)	1.19 (30.16)	9.75 (247.65)	18.12 (469.90)	8.50 (215.90)	287 (130.30)
24 (600)	32.25 (819.15)	28.12 (714.37)	25.88 (657.22)	24.12 (612.77)	8.38 (212.72)	29.50 (749.30)	1.31 (33.34)	11.75 (298.45)	22.25 (565.15)	8.50 (215.90)	335 (152.09)

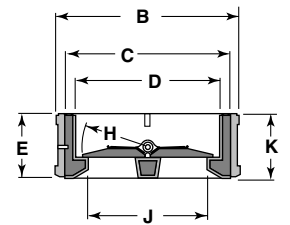
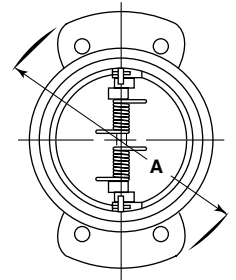

Note: Preferred mounting of check valves of any manufacturer is 8 pipe diameters downstream from the pump discharge or pipe elbow. If this is not feasible, the valve should be mounted downstream as far as possible. This recommendation is not exclusive to Center Line valves, but common practice in valve and piping engineering. Its purpose is to reduce the likelihood of turbulent flow through the valve, which could shorten valve life due to component vibration.

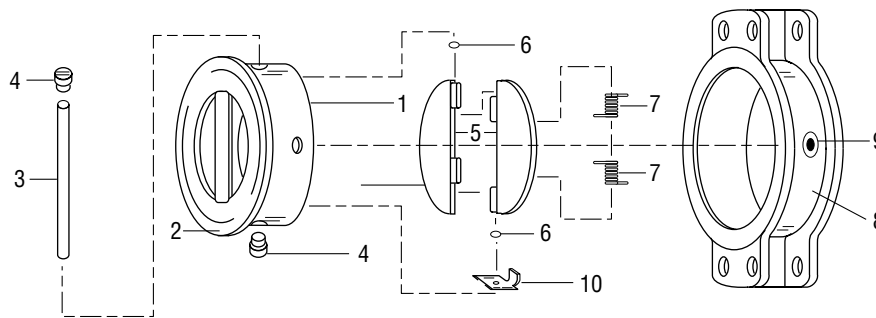

Bill of Materials

Item	Description	Materials	Optional Materials
1*	Valve Body	Ductile Iron	No option available
2*	Liner (Molded to Item 1)	Buna-N or EPDM	Neoprene, Hypalon, Viton
3	Shaft	316 Stainless Steel	Monel
4	Shaft Plug (Qty. 2)	316 Stainless Steel	Monel
5	Plate (Qty. 2)	2" 316 Stainless Steel 2 1/2" -5" Aluminum Bronze 6"-24" Ductile Iron	2"-12" Monel 2 1/2"-12" 316 Stainless Steel 6"-24" Aluminum Bronze
6	Thrust Washer (Qty. 4)	PTFE	No option available
7	Spring (Qty. 2)	316 Stainless Steel	No option available
8	Alignment Body	Cast Iron	No option available
9	Set Screw	Carbon Steel	No option available
10	Plate Travel Stop	316 Stainless Steel (14"-24")	No option available

* Items 1 and 2 must be ordered together.

Handles are available for on/off and throttling control of Center Line resilient seated butterfly valves. These handles can be used for manual actuation of 2" to 12" valves at 200 psi and for 2" to 6" valves at 285 psi. For valves larger than 8", excessive operator effort and extreme handle reaction to internal valve forces are possible. In these cases, a gear operator is recommended for safe operation.

Features

The rugged construction of Center Line handles makes them ideally suited for manually actuating smaller valves. The latchplate permits the valve to be locked in any of the 10 positions on DIT handles or in any position on IOL handles.

Specifications

- DIT Mechanically locks the valve in any of the 10 positions from 0° to 90° in 10° increments
- DIT/IOL Can hold the valve in intermediate positions (32°, 68°, etc.) and can also be locked in 0° and 90° positions



Dimensions and Weights

Valve Size		A	B	Weight
2-6 in.		2.25	10.14	1.8
50-150 mm		57.15	257.56	0.8
8-12 in.		3.34	14.06	4.0
200-300 mm		84.84	357.12	1.8

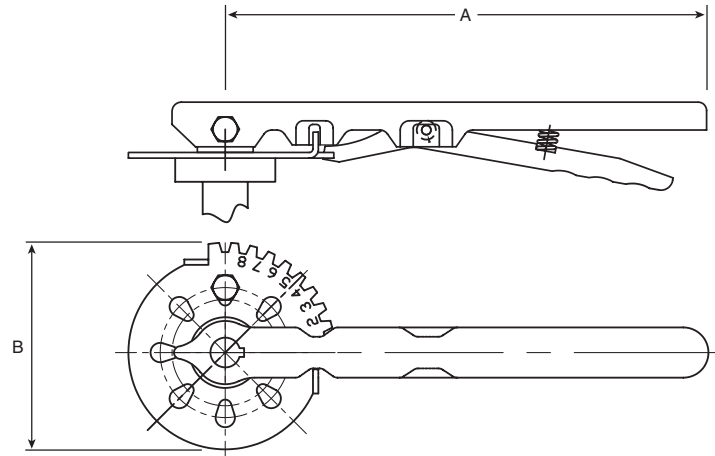

Gear operators can be used for on/off and throttling control of Center Line resilient seated butterfly valves. All models are weatherproof and usable for above ground or buried service. For manual operation of valves, gear operators are required for valves 14" and larger and are recommended for valves 8" and larger.

Features

Gear operators from Center Line are 90° manual actuators, and they come with a handwheel, chainwheel, or square nut input device. The durable housing completely encloses the worm gear (on the input shaft) and the segment gear (on the output). Adjustable stops are standard and factory set when installed at the factory. Fully adjustable memory stops are available as an option. A position indicator is standard on all models for above ground service. An optional version is available for buried service applications. Contact customer service for more information.

Specifications

Operation Handwheel or chainwheel (12" standard, others available) or 2" square nut. Input shaft extension available.

Mounting Available with bolt patterns and bore/keyway for direct mount to all 2" through 30" Center Line resilient seated butterfly valves. Dual bolt patterns accommodate different pad designs.



Dimensions and Weights

Valve Size		Oper.	A	A1	C	E	F	G	H	Ø1	J	ØK	M	D	P	Q	Ø	ØD2	Ø3	Wt.
2-6	in.	XJ30	12.56	9.52	10.72	2.52	14.80	2.36	6.00	0.76	1.36	0.24	1.66	3.68	3.36	7.06	12.00	6.08	1.52	27.1
50-150	mm		314.00	238.00	268.00	63.00	37.00	59.00	150.00	19.00	34.00	6.00	41.50	92.00	84.00	176.50	300.00	152.00	38.00	12.3
8-14	in.	XJ50	12.28	9.04	10.60	3.12	1.54	2.74	5.12	0.76	1.36	0.24	1.53	5.60	3.36	7.90	12.00	6.48	1.52	31.7
200-350	mm		307.00	226.00	265.00	78.00	38.50	68.50	128.00	19.00	34.00	6.00	38.20	140.00	84.00	197.50	300.00	162.00	38.00	14.4
16-18	in.	XJ80	16.28	11.08	13.76	4.80	1.60	4.08	5.60	1.00	1.36	0.32	2.28	7.88	5.00	11.60	18.00	10.40	2.00	77.4
400-450	mm		407.00	277.00	344.00	120.00	40.00	102.00	140.00	25.00	34.00	8.00	57.00	197.00	125.00	290.00	450.00	260.00	50.00	35.2
Valve Size		Oper.	A	B	C	D	E	F	Ø	Ø1	Ø2	Wt.								
20	in.	XJ300	7.40	6.40	4.40	18.90	4.60	2.50	18.00	0.98	0.32	121.0								
500	mm		185.00	160.00	110.00	473.00	115.00	63.00	450.00	25.00	8.00	55.0								
24	in.	XJ300	7.40	6.40	5.00	20.00	4.80	2.50	18.00	0.98	0.32	132.0								
600	mm		185.00	160.00	125.00	500.00	120.00	63.00	450.00	25.00	8.00	60.0								
30	in.	BA800	10.60	6.60	6.40	21.80	5.12	3.12	18.00	0.98	0.32	198.0								
750	mm		265.00	165.00	160.00	545.00	128.00	78.00	450.00	25.00	8.00	90.0								
32	in.	3D-60	9.72	6.92	6.48	21.20	6.56	3.52	17.40	0.98	0.32	292.6								
800	mm	800	243.00	173.00	162.00	530.00	164.00	88.00	435.00	25.00	8.00	133.0								
36	in.	3D-120	11.12	8.04	7.84	21.44	10.32	5.04	17.40	0.98	0.32	424.6								
900	mm	1200	278.00	201.00	196.00	611.00	258.00	126.00	435.00	25.00	8.00	193.0								
42	in.	3D-120	16.72	10.20	9.60	25.56	12.40	5.04	17.40	0.98	0.32	792.0								
1050	mm	1500	418.00	255.00	240.00	611.00	310.00	126.00	435.00	25.00	8.00	360.0								
48	in.	3D-120	16.72	10.20	9.60	25.56	12.40	5.04	17.40	0.98	0.32	792.0								
1200	mm	1500	418.00	255.00	240.00	639.00	310.00	126.00	435.00	25.00	8.00	360.0								

XJ30-50-80

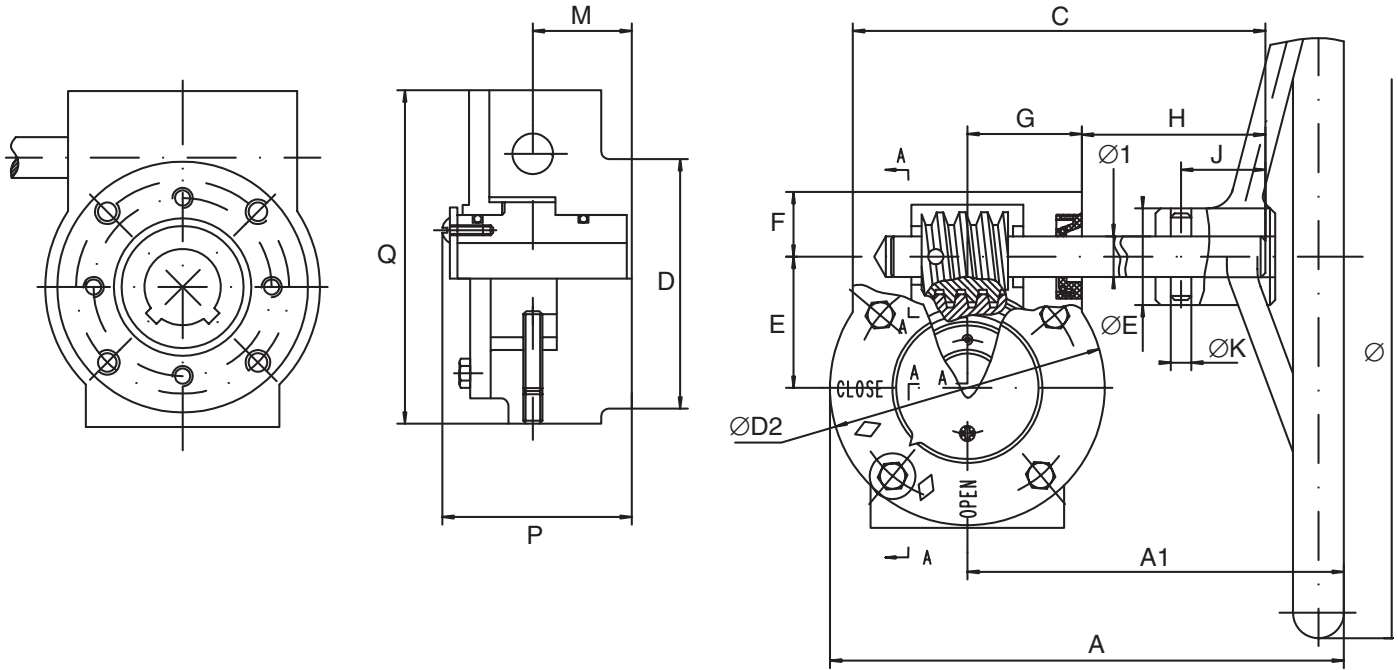

XJ300-BA800-3D-60-3D-120

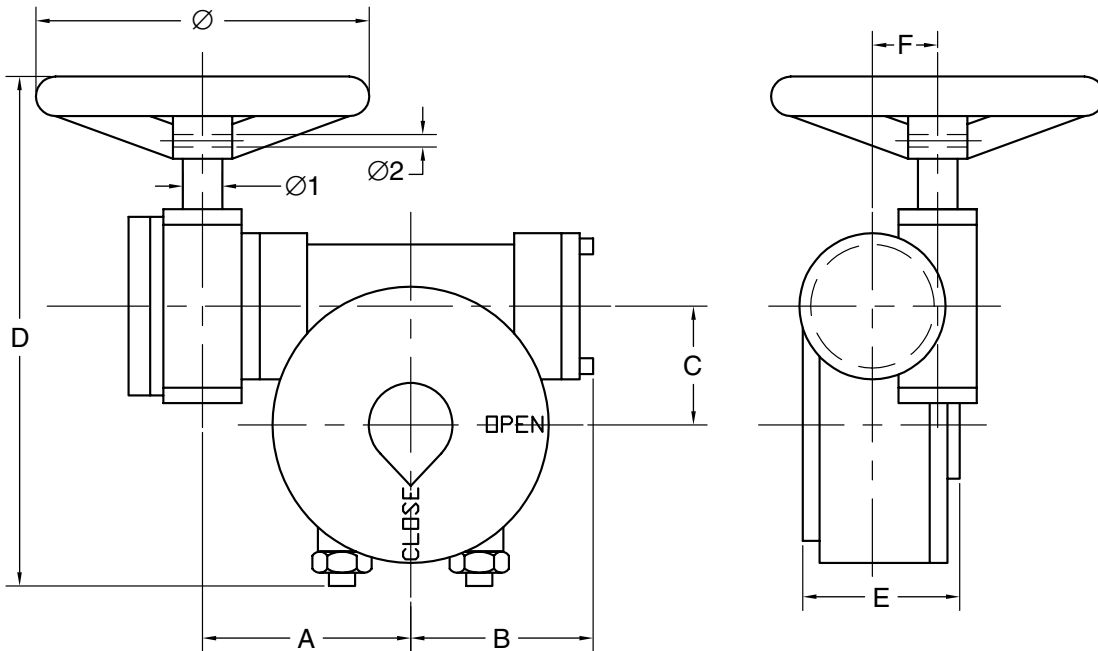

Gear Operator Drilling Patterns

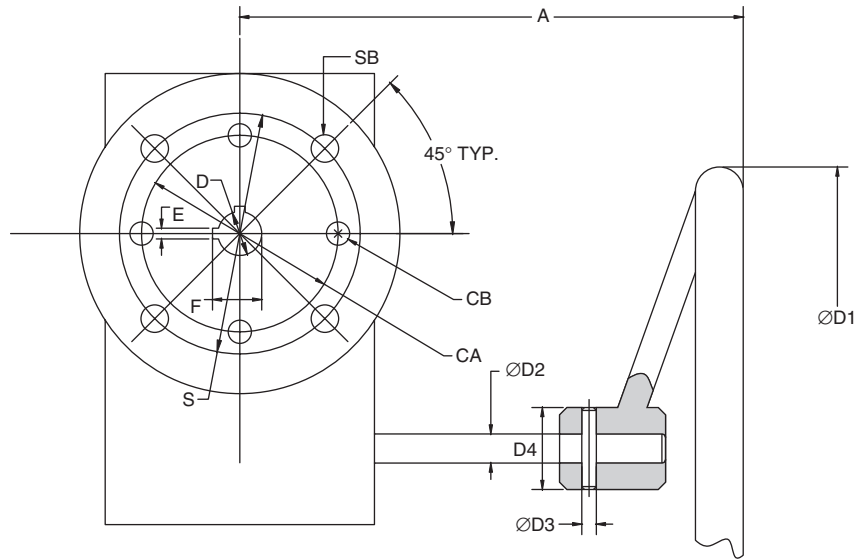

Dimensions

Valve Size	Operator Model	CA	CB	SA	SB	D	D1	D2	D3	D4	A	E	F
2 in. 50 mm	XJ30	2.25 57.15	M6-1	2.76 70.00	M8-1.25	0.50 12.70	11.81 300.00	0.75 19.00	0.24 6.00	1.50 38.00	9.37 238.00	0.13 3.18	0.56 14.30
3 in. 75 mm	XJ30	2.25 57.15	M6-1	2.76 70.00	M8-1.25	0.50 12.70	11.81 300.00	0.75 19.00	0.24 6.00	1.50 38.00	9.37 238.00	0.13 3.18	0.56 14.30
4 in. 100 mm	XJ30	2.75 69.85	M8-1.25	2.76 70.00	M8-1.25	0.63 15.90	11.81 300.00	0.75 19.00	0.24 6.00	1.50 38.00	9.37 238.00	0.13 3.18	0.72 18.30
5 in. 125 mm	XJ30	2.75 69.85	M8-1.25	2.76 70.00	M8-1.25	0.75 19.05	11.81 300.00	0.75 19.00	0.24 6.00	1.50 38.00	9.37 238.00	0.13 3.18	0.84 21.40
6 in. 150 mm	XJ30	2.75 69.85	M8-1.25	2.76 70.00	M8-1.25	0.75 19.05	11.81 300.00	0.75 19.00	0.24 6.00	1.50 38.00	9.37 238.00	0.13 3.18	0.84 21.40
8 in. 200 mm	XJ50	3.50 88.90	M12-1.75	4.02 102.00	M10-1.5	0.87 22.20	11.81 300.00	0.75 19.00	0.24 6.00	1.50 38.00	8.89 226.00	0.19 4.76	0.97 24.50
10 in. 250 mm	XJ50	3.50 88.90	M12-1.75	4.02 102.00	M10-1.5	1.13 28.60	11.81 300.00	0.75 19.00	0.24 6.00	1.50 38.00	8.89 226.00	0.25 6.35	1.25 31.80
12 in. 300 mm	XJ50	4.25 107.95	M12-1.75	4.02 102.00	M10-1.5	1.25 31.80	11.81 300.00	0.75 19.00	0.24 6.00	1.50 38.00	8.89 226.00	0.25 6.35	1.39 35.00
14 in. 350 mm	XJ50	4.25 107.95	M12-1.75	4.02 102.00	M10-1.5	1.25 31.80	11.81 300.00	0.75 19.00	0.24 6.00	1.50 38.00	8.89 226.00	0.25 6.35	1.39 35.00
16 in. 400 mm	XJ80	6.25 158.75	M18-2.5	6.50 165.00	M20-2.5	1.31 33.30	18.00 450.00	0.98 25.00	0.32 8.00	1.99 50.00	10.90 277.00	0.31 7.90	1.49 37.30
18 in. 450 mm	XJ80 (42/44)	6.25 158.75	M18-2.5	6.50 165.00	M20-2.5	1.50 38.10	18.00 450.00	0.98 25.00	0.32 8.00	1.99 50.00	10.90 277.00	0.38 9.53	1.69 42.80
18 in. 450 mm	XJ300 (21/23)	6.25 158.75	M18-2.5	6.50 165.00	M20-2.5	1.63 41.30	18.00 450.00	0.98 25.00	0.32 8.00	1.99 50.00	12.64 321.00	0.38 9.53	1.81 46.00
20 in. 500 mm	XJ300	6.25 158.75	M18-2.5	6.50 165.00	M20-2.5	1.63 41.30	18.00 450.00	0.98 25.00	0.32 8.00	1.99 50.00	12.64 321.00	0.38 9.53	1.81 46.00
24 in. 600 mm	XJ300 (42/44)	8.50 215.90	M20-2.5	6.50 165.00	M20-2.5	2.00 50.80	18.00 450.00	0.98 25.00	0.32 8.00	1.99 50.00	13.19 335.00	0.50 12.70	2.24 56.80
24 in. 600 mm	XJ300 (21/23)	8.50 215.90	M20-2.5	6.50 165.00	M20-2.5	2.00 50.80	18.00 450.00	0.98 25.00	0.32 8.00	1.99 50.00	13.19 335.00	0.50 12.70	2.24 56.80

Series 225

1	1	2	3	4	5	6	7	8	9	10
---	---	---	---	---	---	---	---	---	---	----

1. Size	Code
2"	02
2.5"	25
3"	03
to	
24"	24

2. Series/Style	Code
Wafer	J
Lug	K
Lug Dead End	L
Lug ASME 300 BC	M
Lug ASME 300 DES	N

3. Body	Code
Ductile Iron (A536)	2
Epoxy Coated DI (A536)	V
Ductile Iron (A395)	G

4. Pressure	Code
200 PSI (2"-12") DES	0
285 PSI	5
150 PSI (14"-24") DES	6

5. Disc	Code
DI - ENP (2"-12")	2
316 SS	4
DI - (14"-24")	5
Aluminum Bronze	6
Monel	7

6. Shaft	Code
416 SS	1
316 SS	4
Monel 400	7
17-4 PH	9

7. Bushings	Code
PTFE	3

8. Seat/Liner	Code
Buna-N	1
Neoprene	3
EPDM	5
Viton (275° F)	6
Hypalon	7
Viton (400° F)	P
EPDM (FDA)	V
White Buna-N	B

9. Actuator	Code
Handle	2
Infinite/Lockable (2"-6")	3
Infinite (8")	4
Gear Operator	5
Double Acting	6
Fail Close - SR	7
Fail Open - SR	8
Electric	9
Gear Operator/Balancing	G
Buried Gear/2" Nut	D
Chain Wheel	U
None	X

10. Custom	Code
Custom Product	D

Series 250

1	1	2	3	4	5	6	7	8	9	10
---	---	---	---	---	---	---	---	---	---	----

1. Size	Code
2"	02
2.5"	25
3"	03
to	
24"	24

2. Series/Style	Code
Wafer	2
Lug	4
Lug DES	6

3. Body	Code
Carbon Steel	3
316 Stainless Steel	4

4. Pressure	Code
200 PSI (2"-12") DES	0
285 PSI	5
150 PSI (14"-24") DES	6
125 PSI (2"-12") PTFE	8

5. Disc	Code
316 SS	4
Aluminum Bronze	6
Monel 400	7

6. Shaft	Code
416 SS	1
316 SS	4
Monel 400	7
17-4 PH	9

7. Bushings	Code
PTFE	3

8. Seat/Liner	Code
Buna-N	1
Neoprene (black)	3
EPDM	5
Viton (275° F)	6
Hypalon	7
PTFE/Buna-N	L
Viton (400° F)	P
EPDM (FDA)	V
White Buna-N (FDA)	W
White Buna-NB	

9. Actuator	Code
Handle	2
Infinite/Lockable (2"-6")	3
Infinite (8")	4
Gear Operator	5
Double Acting	6
Fail Close - SR	7
Fail Open - SR	8
Electric	9
Gear Operator/Balancing	G
Buried Gear/2" Nut	C
Direct 2" Nut	D
Chain Wheel	U
None	X

10. Custom	Code
Custom Product	D

Series 300



1. Size	Code	4. Pressure	Code	8. Seat/Liner	Code
2"	02	200 PSI	0	Buna-N	1
2.5"	25	125 PSI PTFE	8	Neoprene	3
3"	03			EPDM	5
to				Viton (275° F)	6
12"	12			Hypalon	7
				Viton (400° F)	P
				EPDM (FDA)	V
				White Buna-N (FDA)	W
				White Buna-N	B

2. Series/Style	Code	5. Disc	Code	9. Actuator	Code
Wafer	5	316 SS	4	Handle	2
Lug	3	Aluminum Bronze	6	Infinite/Lockable (2"-6")	3
				Infinite (8")	4
				Gear Operator	5
				Double Acting	6
				Fail Close (SR)	7
				Fail Open (SR)	8
				Electric	9
				Gear Operator/Balancing	G
				Chain Wheel	U
				None	X

3. Body	Code	6. Shaft	Code	7. Bushings	Code
Epoxy Coated CI (A536)	S	416 SS	1	PTFE	3
Epoxy Coated DI (A536)	V	316 SS	4		
Cast Iron	1				
Ductile Iron (A536)	2				
Carbon Steel	3				
316 Stainless Steel	4				

Series 700

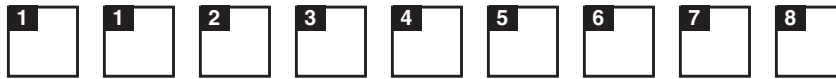

1. Size	Code
1"	01
1.5"	15
2"	02
2.5"	25
3"	03
4"	04
5"	05
6"	06
8"	08
10"	10
12"	12

2. Series/Style	Code
Split Body Lug	X
Split Body Wafer	Y

3. Body	Code
Ductile Iron - A395	G
255 Duplex SS	E
Aluminum	A

4. Pressure	Code
150 PSIG	6
100 PSIG	4
50 PSIG (undercut)	9

PTFE coated-disc/stem and seat combination de-rated to 100 psig

5. Disc/Shaft	Code
255 Duplex SS	E
255 Duplex SS/PTFE	T
255 Duplex SS/EPDM	P
255 Duplex SS/Buna	B

6. Seat	Code
Buna N*	2
Buna N - White*	W
EPDM	5
Viton - 400° F	P
PTFE/EPDM	M
PTFE/Buna N	L
PTFE/Viton	N

*FDA Approved and Abrasion Res.

7. Actuator	Code
None	X
10 Pos. Handle (DI)	H
10 Pos. Handle (SS)	S
Gear Operator	O
Double Acting	6
Fall Close (SR)	7
Fall Open (SR)	8
Electric	9

8. Special Features	Code
Custom Product	D

Series 800

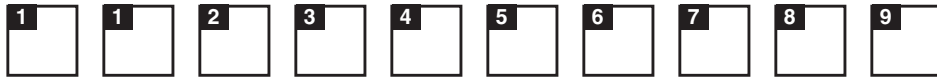

1. Size	Code
2"	02
2.5"	25
3"	03
to 24"	24

2. Series/Style	Code
Wafer	R
Euro	W

3. Body	Code
Cast Iron	1
Epoxy Coated CI (A536)	S
None	X

4. Pressure	Code
150 PSI	6

5. Plate	Code
316 SS	4
Ductile Iron	5
Aluminum Bronze	6
Monel	7

6. Shaft	Code
316 SS	4
Monel	7

7. Springs	Code
316 SS	D
Monel 400	M

8. Seat/Liner	Code
Buna-N	1
Neoprene	3
EPDM	5
Hypalon	7
Viton	0

9. Actuator	Code
None	X

ELECTRIC – ON-OFF**Standard Features:**

Torque Range – 347 lb ins to 17,359 lb ins
 Housing – NEMA 4 & 4X
 Electric Motor – 120 VAC, 1 PHASE, 60 Hz
 Thermal Overload – Auto re-set
 Limit Switches – Adjustable cam operated
 Position Indicator – Mechanical Dial Type
 Space Heater – Located in the control compartment
 Terminal Strip – Pre-wired for motor & limit switches
 Manual Override – Directing acting
 Brake – “Lock-cut” gear arrangement
 Adjustable Mechanical Travel Stops
 Temperature Range – 13°F to 150°F
 Mounting – Direct mount to Crane valves
 Certification/Approvals – CSA-NRTL/C

Optional Features:

AC Voltages – 220 VAC, 1 PHASE, 60 Hz
 AC Voltages – 24 VAC 44005 - 44400
 DC Voltages – 12/24 VDC 4005 - 44300
 Additional Limit Switches – 2 SPDT
 Torque Switches – Adjustable open and close
 Feedback Potentiometer – 500 ohm
 Feedback Transmitter – 4-20 mA
 De-clutchable Handwheel Override

**ELECTRIC – MODULATING****Standard Features:**

Process Control Signal – 4-20 mA, 0-10 VDC
 Torque Range – 347 lb ins to 17,359 lb ins
 Housing – NEMA 4 & 4X
 Electric Motor – 120 VAC, 1 PHASE, 60 Hz
 Thermal Overload – Auto re-set
 Resolution – 400 increments through 90 degrees
 Position Indicator – Mechanical Dial Type
 Space Heater – Located in the control compartment
 Terminal Strip – Pre-wired for motor & limit switches
 Manual Override – Directing acting
 Brake – “Lock-cut” gear arrangement
 Adjustable Mechanical Travel Stops
 Temperature Range – 130°F to 1500°F
 Mounting – Direct mount to Crane valves
 Certification/Approvals – CSA-NRTL/C

Optional Features:

AC Voltages – 220 VAC, 1 PHASE, 60 Hz
 AC Voltages – 24 VAC 44010M - 44200M
 Torque Switches – Adjustable open and close
 De-clutchable Handwheel Override

PNEUMATIC – DOUBLE ACTING

Standard Features:

Torque Range – 30 in-lbs to 107,531 in-lbs
Housing – Anodized aluminum
Mounting – DIN ISO 5211
Position Indicator – NAMUR standard
Operating Pressure – 40 to 120 PSIG
Temperature Range – -4°F (-20°C) to 176°F (80°C)
Size Range – 14 models to choose from
Adjustable Travel Stops – Both directions
Accessory Interfaces – VDI/VDE 3845 (NAMUR) standard

Optional Features:

Temperature Range – 4°F to 250°F, -40°F to 175°F
Solenoid Valves – 3 or 4 way
Limit Switches – Adjustable cam operated
Positioners – Pneumatic or Electro-pneumatic
DC-1 Dribble Control – Two-stage shutoff
180° Actuation – 2 or 3 position
Manual Override – De-clutchable gear type
Speed Controls – Adjust cycle time
Special Applications – Offshore, nuclear, hygienic, and gas or oil operation

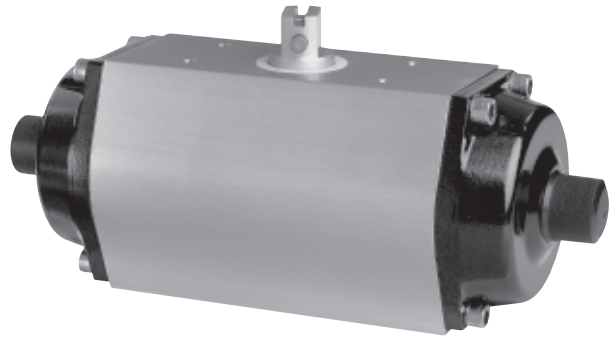

PNEUMATIC – SPRING RETURN

Standard Features:

Torque Range – 42 in-lbs to 77,211 in-lbs
Housing – Anodized aluminum
Mounting – DIN ISO 5211
Position Indicator – NAMUR standard
Operating Pressure – 40 to 120 PSIG
Temperature Range – -4°F (-20°C) to 176°F (80°C)
Size Range – 14 models to choose from
Adjustable Travel Stops – Both directions
Accessory Interfaces – VDI/VDE 3845 (NAMUR) standard

Optional Features:

Temperature Range – 4°F to 250°F, -40°F to 175°F
Solenoid Valves – 3 or 4 way
Limit Switches – Adjustable cam operated
Positioners – Pneumatic or Electro-pneumatic
DC-1 Dribble Control – Two-stage shutoff
180° Actuation – 2 or 3 position
Manual Override – De-clutchable gear type
Speed Controls – Adjust cycle time
Special Applications – Offshore, nuclear, hygienic, and gas or oil operation

VANE

Standard Features:

Double acting and fail safe versions available
Housing – Die-cast aluminum
Operating Pressure – 40 to 120 PSIG
Temperature Range – 0°F to 225°F
Powerful actuation in a compact and lightweight package
Only one moving part
Dual external travel stops allow rotation adjustment of up to $\pm 10^\circ$ at each end of the stroke
Fail safe models use a pneumatic accumulator to assure valve closure upon loss of supply pressure
Stacking two vane actuators enables 180° movement (2 or 3 position)

Optional Features:

Limit switch
Locking device
Breather block
Dribble control
Sandwich de-clutchable manual gear override
Solenoid valve
Positioners
PTFE interior coatings
High or low temperature trim

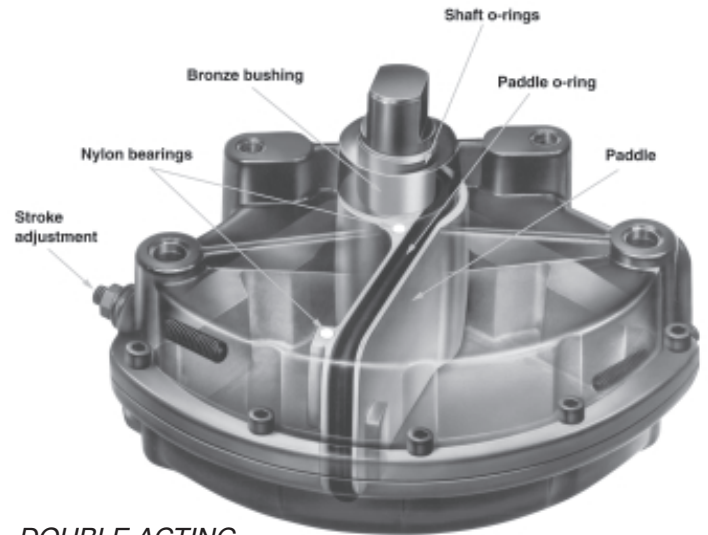

DOUBLE ACTING

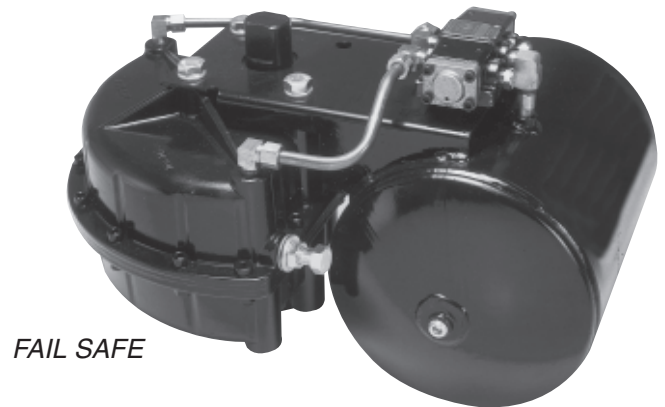

FAIL SAFE

The nomograph on the opposite page gives the relationships of valve size, flow, velocity, and pressure drop for various disc positions.

Sample Calculation, Liquid (see dark green line on chart)

Given:

Water (1.0 specific gravity) at 60°F is flowing through a 6-inch valve at a rate of 1000 gpm.

Find:

Line velocity (ft./sec.) and pressure drop when valve is in full-open (disc at 90°) position.

Solution:

From the 6-inch valve size at lower left of nomograph, go diagonally up to the intersecting horizontal line for 1000 gpm. From that point, proceed directly down to determine line velocity as 11 ft./sec.

For pressure drop, return to the 1000 gpm intersection and continue up vertically to "90° disc open" intersecting diagonal line. From this point, go horizontally to the left to determine pressure drop as 0.5 psi.

Sample Calculation, Gas (see light green line on chart)

Given:

Gas (0.8 lb/cu. ft. density) is flowing through an 8-inch valve at a rate of 1500 cu. ft./min.

Find:

Line velocity (ft./min.) and pressure drop when valve is in full-open (disc at 90°) position.

Solution:

From 8-inch valve size at lower left of nomograph, go diagonally up to the intersecting horizontal line for 1500 cu. ft./min. From that point, proceed directly down to the bottom line of the nomograph to determine line velocity as 4000 ft./min.

For pressure drop, return to the 1500 cu. ft./min. intersection and continue up vertically to "90° disc open" intersecting diagonal line. From this point, go horizontally to the left to determine pressure drop as 17 psi. Now, convert pressure drop to gas by dividing gas density by liquid density and multiplying by 17.

$$\frac{0.8}{62.34} \times 17.0 = 0.22 \text{ psi}$$

General Notes

- Liquid flow data is based on pressure drop and flow rate with viscosity similar to water at 60° F using flow coefficient.
- Velocities for liquids with densities similar to water should be less than 16 ft./sec.
- Nomograph flow rate for gases is in cubic feet per minute (CFM) at flowing conditions. To convert flow rate from standard cubic feet per minute to CFM, use the following formula:

$$\text{CFM} = \frac{(\text{SCFM} \times 14.7) \times (460 + ^\circ\text{F})}{(\text{line pressure, psia}) \times 520}$$

- Gas density in lbs./cu. ft. equals:

$$\frac{\left(\frac{270 \times}{\text{line pressure, psia}} \right) \times \left(\frac{\text{specific gravity of gas (relative to air)}}{460 + ^\circ\text{F}} \right)}$$

Size	Cv at Full-Open
2"	115
2 1/2"	196
3"	302
4"	600
5"	1022
6"	1579
8"	3136
10"	5340
12"	8250
14"	11917
16"	16388
18"	21705
20"	27908
24"	43116
30"	73426

Definitions

C_v = Flow coefficient for valves; expresses flow rate in gallons per minute of 60°F water with 1.0 psi pressure drop across valve.

$$C_v = Q \sqrt{\frac{P}{62.4 \Delta P}}$$

K = resistance coefficient.

$$K = d \sqrt{\frac{29.9}{C_v}}$$

P = weight density of fluid, in pounds per cubic foot.

d = internal diameter of Schedule 40 pipe, in inches.

Q = rate of flow, in gallons per minute.

ΔP = differential pressure, in pounds per square inch gauge.

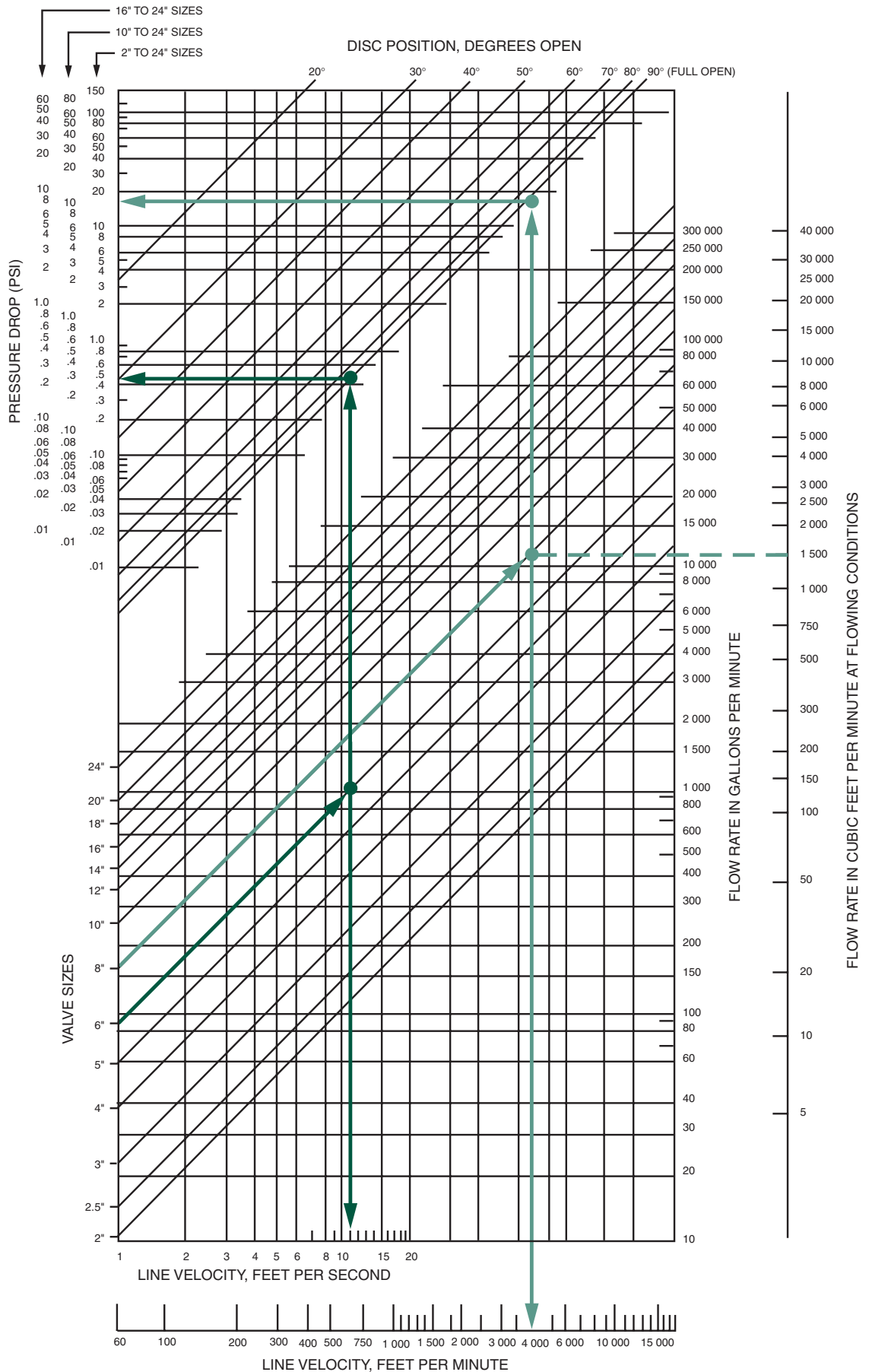

Center Line®

Global Headquarters
9200 New Trails Drive
The Woodlands, Texas 77381-5219
Tel: 281-298-5463
Fax: 281-292-1749

Thomastown, Australia Operations
322 Settlement Road
Thomastown, VIC 3074
Tel: +61-39-465-2755
Fax: +61-39-466-1365

Sydney, Australia Operations
146-154 Dunheved Circuit
St. Mary's, N.S.W. 2760
Sydney, Australia
Tel: +61-29-623-0234
Fax: +61-29-673-3870

W. Sussex UK Operations
Gerrard House, Worthing Road
East Preston, Littlehampton
West Sussex, BN16 1AW
Tel: +441-903-779111
Fax: +441-903-779222

Ningjin Operations
No. 8 Youyi Street Ningjin County
Hebei Province, China 055550
Tel: +86-319-580-6651
Fax: +86-319-580-8661

www.cranevalve.com

Crane Valves North America

Thinking Globally

CENTER LINE®

Resilient Seated Butterfly and Check Valves
Pneumatic and Electric Actuators

FLOWSEAL®

High Performance Butterfly Valves

DUO-CHEK®

High Performance Wafer Check Valves

NOZ-CHEK®

Severe Service Check Valves

PACIFIC

High Pressure and Severe Service Valves
Quarter Turn Severe Service Plug Valves

CRANE

Cast Steel, Bronze and Iron Valves

JENKINS

Bronze, Iron and Cast Steel Valves

ALOYCO

Corrosion Resistant Gate, Globe and Check Valves

CRANE NUCLEAR, INC.

Valves Designed for Nuclear Service
Diagnostic Valve Repair, Equipment and Services

CRANE SERVICE CENTERS

Certified OEM Valve Repair Services