



Displacer Type Liquid Level Switches

DESCRIPTION

Magnetrol's displacement type level switches offer the industrial user a wide choice of alarm and control configurations. Every unit utilizes a simple buoyancy principle and is well suited for simple or complex applications, such as foaming or surging liquids or agitated fluids, and usually costs less than other types of level switches.

FEATURES

- Narrow or wide level ranges achieved through multiple switch mechanism capability.
- Displacers adjustable at any point along the suspension cable.
- 10 ft (3 m) suspension cable standard
- Anti-surge design eliminates the possibility of switch shortcycling
- Flanged or threaded mounting available
- Easy installation
- Field adjustable set point and switch differential
- NACE models
- Floating roof top models
- Proof-er® ground check
- Choice of displacers: Porcelain, 316 Stainless steel, Karbate, Lead
- Choice of switch mechanisms: Dry contact, Pneumatic, Hermetically sealed
- Available housings: NEMA 1, carbon steel for pneumatics; TYPE 4X/7/9, Class I, Div. 1, Groups C & D, polymer coated aluminum; TYPE 4X/7/9, Class I, Div. 1, Group B, polymer coated aluminum



**Displacer
Level Switch**

**Displacer
Level Switch
with Proof-er**

APPLICATIONS

- Foaming or surging liquids
- Agitated fluids
- Sewage handling
- Dirty liquids
- Paints
- Varnishes
- Heavy oils
- Liquids with solids

TECHNOLOGY

Operation is based upon simple buoyancy, whereby a spring is loaded with weighted displacers which are heavier than the liquid. Immersion of the displacers in the liquid results in buoyancy force change, which moves the spring upward.

Since the spring moves only when the level moves on a displacer, spring movement ① is always a small fraction of the level travel between displacers ②.

A magnetic sleeve ③ is connected to the spring and operates within a non-magnetic barrier tube ④. Spring movement causes the magnetic sleeve to attract a pivoted magnet ⑤, actuating a switch mechanism ⑥ located outside the barrier tube. Built-in limit stops prevent over stroking of the spring, under level surge conditions.

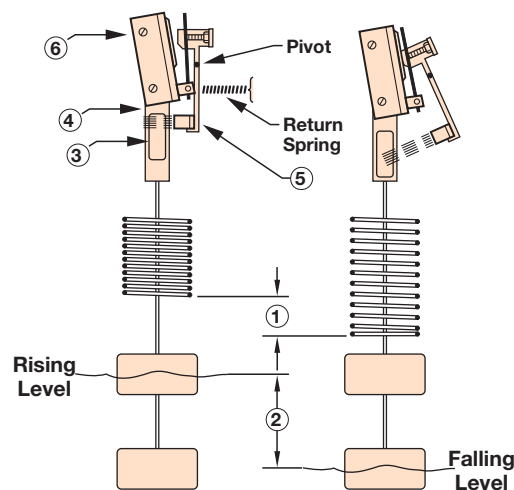

PROOF-ER CONTROLS

The purpose of the Proof-er is to check the operation of a displacer control without having to raise the level in the tank. This is accomplished by pulling downward on the Proof-er chain. A spring-loaded lever arm then lifts the

switch actuator simulating a high or high-high level condition. When the chain is released, the Proof-er returns the actuator to its previous position to resume normal operation.

PROOF-ER ROOF TOP CONTROLS

The Proof-er roof top control is designed for installation on "barrier" (floating roof) tanks. The control may be furnished with a lead displacer to prevent sparking.

A stainless steel displacer is required if the control is to actuate in liquid as well as by the barrier. Consult factory for this option.

DISPLACERS

Stainless steel displacers are rated 720 psig @ +100° F (50 bar @ +38° C).

Karbate displacers are limited to a minimum temperature of +32° F (0° C) and a maximum temperature of +300° F (+149° C).

Do not use porcelain displacers on non-vented boiler water condensate systems over +200° F (+93° C). Stainless steel or Karbate is recommended.

DISPLACERS SUSPENSION CABLE

Displacers are field-adjustable at any point along the suspension cable (10 feet (3 meters) 316 stainless steel is

standard). Monel® and Hastelloy® materials are available. Consult the factory for longer lengths.

SINGLE SWITCH MODELS

SERIES A10 AND SERIES A15

SERIES A10 PUMP OR VALVE CONTROL WIDE DIFFERENTIAL TYPE

These wide differential units are factory calibrated to actuate as a liquid level reaches a given displacer and to deactuate when the level reaches a second displacer.

The minimum differential band is approximately 6 in. (152 mm) in water and varies somewhat with liquid specific gravity. The maximum differential is determined by the length of the displacer suspension cable.

SERIES A15 LEVEL ALARM APPLICATIONS NARROW DIFFERENTIAL TYPE

These instruments are factory calibrated to operate over a narrow level differential band and are ideally suited for liquid level alarm applications on either high or low level.

The operating level is fully adjustable simply by repositioning the displacer along its suspension cable. The differential band varies slightly with liquid specific gravity.

DUAL SWITCH MODELS

SERIES B10 AND SERIES B15

SERIES B10 WIDE DIFFERENTIAL TYPE

These wide differential tandem units are factory calibrated with a choice of several operating sequences designed to meet virtually any application.

OPERATING SEQUENCES

Model B10 units are available with a choice of switch operating sequence. Five of the most popular sequences are described on page 8. When ordering, specify operating sequence number and specific gravity of the liquid.

SERIES B15 NARROW DIFFERENTIAL TYPE

These instruments utilize two switches — each actuated at a different level and each calibrated with a narrow differential band.

TRI-SWITCH MODELS

SERIES C10 AND SERIES C15

SERIES C10 WIDE DIFFERENTIAL TYPE





These wide differential type switches are designed to provide three electrically separate control signals in a selected sequence as liquid level varies.

These units come factory-calibrated with a choice of several operating sequences combining wide and narrow level differential.

SERIES C15 NARROW DIFFERENTIAL TYPE

These instruments are factory-calibrated to operate over a narrow level band while providing three electrically separate control signals as liquid level varies.

AGENCY APPROVALS

AGENCY	APPROVED MODEL	AREA CLASSIFICATION
FM 	All with an electric switch mechanism and a housing listed as Type 4X/7/9 ①	Class I, Div 1, Groups C & D Class II, Div 1, Groups E, F & G
	All with an electric switch mechanism and a housing listed as Type 4X/7/9 Class I, Div 1, Group B	Class I, Div 1, Groups B, C & D Class II, Div 1, Groups E, F & G
CSA 	All with a Series HS or F electric switch mechanism and a housing listed as CSA Type 4X	Class I, Div 2, Groups B, C & D
	All with an electric switch mechanism and a housing listed as Type 4X/7/9 ①	Class I, Div 1, Groups C & D Class II, Div 1, Groups E, F & G
	All with an electric switch mechanism and a housing listed as Type 4X/7/9 Class I, Div 1, Group B	Class I, Div 1, Groups B, C & D Class II, Div 1, Groups E, F & G
ATEX / IEC Ex ② 	All with an electric switch mechanism and an ATEX housing ①	ATEX II 2 G EEx d IIC T6 IEC Ex Ex d IIC T6
CE 	All models	Installation Category II Pollution Degree 2 Low Voltage Directives 73/23/EEC & 93/68/EEC per Harmonized Standard EN 61010-1/1993 & Amendment No. 1

① Controls with two or more HS or H1 switches are not ATEX approved.

② IEC Installation Instructions:

The cable entry and closing devices shall be Ex d certified suitable for the conditions of use and correctly installed.

For ambient temperatures above +55° C or for process temperatures above +150° C, suitable heat resistant cables shall be used.

Heat extensions (between process connection and housing) shall never be insulated.

Special conditions for safe use:

When the equipment is installed in process temperatures higher than +85° C the temperature classification must be reduced according to the following table as per IEC60079-0.

Maximum Process Temperature	Temperature Classification
< 85° C	T6
< 100° C	T5
< 135° C	T4
< 200° C	T3
< 300° C	T2
< 450° C	T1

These units are in conformity with IECEx KEM 05.0020X
Classification Ex d IIC T6
T_{ambient} -40° C to +70° C

PRESSURE / TEMPERATURE RATINGS

Threaded Models ③	800 psig @ +100° F (55 bar @ +38° C) 250 psig @ +400° F (17 bar @ +204° C)
Flanged Models	Limited to the pressure rating of the selected flange or displacer. Cast iron flanges are flat face type conforming to ANSI dimensional specifications.
Low Pressure Proof-er Models	25 psig @ +200° F (1.7 bar @ +93° C)
Medium Pressure Proof-er Models	125 psig @ +300° F (8.6 bar @ +149° C)

③ Models with stainless steel displacers are rated 720 psig @ +100° F (50 bar @ 38° C).

SPECIFICATIONS

SWITCH MECHANISMS AND ENCLOSURES

AVAILABLE SWITCH MECHANISMS

Displacer level switches are available with a range of different switch mechanisms — each designed for specific service conditions. Brief descriptions of the individual switch mechanisms and their application are given below.



SERIES B, C, D, O & Q DRY CONTACT SWITCHES

- For applications where mercury must be avoided
- Series “B”, “C”, “O” and “Q” switches are general purpose units with a selection of maximum liquid temperature ratings
- Series “D” switch is designed for high DC current applications



SWITCH ENCLOSURES

- TYPE 4X/7/9 aluminum enclosures
- Designed and approved for Class I, Div. 1, Groups C & D and Class I, Div. 1 Group B
- Optional housing heaters and drains available for some enclosures
- Pneumatic switch mechanisms available with a NEMA 1 enclosure

BASIC ELECTRICAL RATINGS

Voltage	Switch Series and Non-Inductive Ampere Rating					
	B	C	D	HS	O	Q
120 VAC	15.00	15.00	10.00	5.00	15.00	15.00
240 VAC	15.00	15.00	—	5.00	15.00	15.00
24 VDC	6.00	10.00	10.00	5.00	—	6.00
120 VDC	0.50	1.00	10.00	0.50	1.00	0.50
240 VDC	0.25	0.50	3.00	0.25	0.50	0.25



SERIES J & K PNEUMATIC SWITCHES

- Suited for process industry applications in hazardous locations or where electrical power is not available
- Series “J” bleed type switch is intended for general purpose applications
- Series “K” switch is specially designed to provide non-bleed operation with a high degree of vibration resistance



SERIES HS & F HERMETICALLY SEALED SWITCHES

- Entire mechanism and contacts are contained within a positively pressurized capsule with series ‘HS’
- Ideal for use in salt and other corrosive atmospheres
- Available in two models, one with easy access terminals, another with 12" (305 mm) long exposed wiring leads which may be field connected away from the switch enclosure

SPECIFICATIONS

MODEL A10 DIMENSIONAL DATA AND ACTUATION LEVELS

INCHES (MM)

Outline Dimensions				
Displacer Type	Threaded Mounting		Flanged Mounting	
	A	B	A	B
Porcelain	5.00 (127)	122.00 (3098)	7.00 (177)	124.00 (3149)
Stainless Steel or Karbate	4.75 (120)	122.00 (3098)	6.75 (171)	124.00 (3149)

Displacer Type	C	D	E
Porcelain	2.56 (65)	7.25 (184)	3.62 (91)
Stainless Steel or Karbate	2.50 (63)	9.00 (228)	4.50 (114)

Electrical Connections
TYPE 4X/7/9, Group B: 1" NPT NEMA 1 Pneumatic: ¼" NPT

STANDARD ACTUATING LEVELS AND LIQUID SPECIFIC GRAVITY

Displacer Type	Liquid Temp. °F	0.60		0.70		0.80		0.90		1.00	
		F	G	F	G	F	G	F	G	F	G
Porcelain	100	5.30 (134)	1.50 (38)	4.10 (104)	1.20 (30)	3.20 (81)	1.10 (27)	2.50 (63)	1.00 (25)	2.00 (50)	0.90 (22)
	200	—	—	4.80 (121)	2.00 (50)	3.80 (96)	1.80 (45)	3.00 (76)	1.60 (40)	2.50 (63)	1.50 (38)
	300	—	—	—	—	4.30 (109)	2.40 (60)	3.40 (86)	2.10 (53)	2.90 (73)	1.90 (48)
	400	—	—	—	—	—	—	3.40 (86)	2.60 (66)	2.90 (73)	2.40 (60)
Stainless Steel or Karbate	100	7.00 (177)	2.40 (60)	5.30 (134)	2.00 (50)	4.10 (104)	1.80 (45)	3.10 (78)	1.60 (40)	2.40 (60)	1.40 (35)
	200	—	—	5.90 (149)	2.80 (71)	4.70 (119)	2.50 (63)	3.60 (91)	2.20 (55)	2.80 (71)	2.00 (50)
	300	—	—	—	—	5.10 (129)	3.10 (78)	4.00 (101)	2.70 (68)	3.20 (81)	2.40 (60)
Stainless Steel	400	—	—	—	—	—	—	4.40 (111)	3.20 (81)	3.60 (91)	2.90 (73)
	500	—	—	—	—	—	—	—	—	3.90 (99)	3.30 (83)

Note: All levels $\pm 0.25"$ (6).

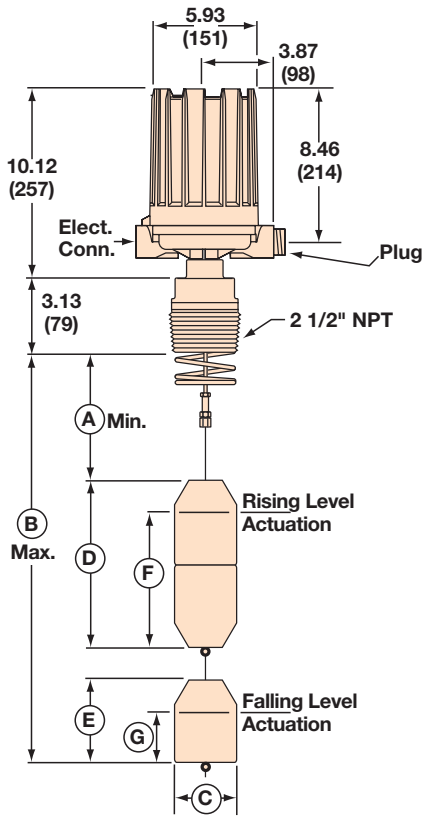

Model A10
with Threaded Mounting

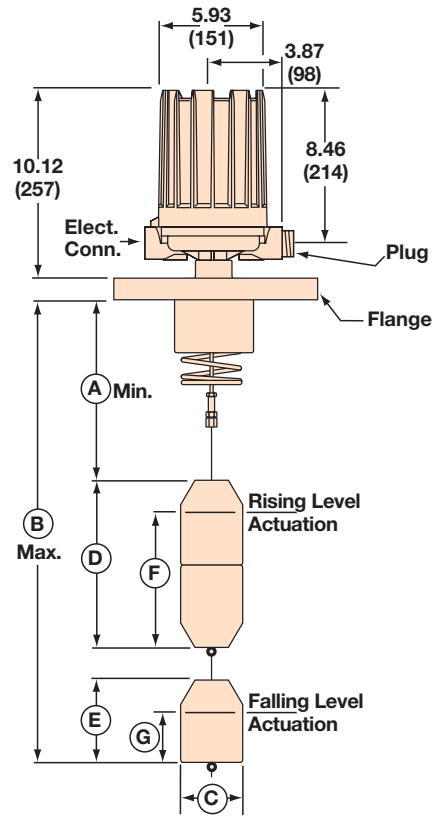

Model A10
with Flanged Mounting

SPECIFICATIONS

MODEL A15 DIMENSIONAL DATA AND ACTUATION LEVELS

INCHES (MM)

Outline Dimensions				
Displacer Type	Threaded Mounting		Flanged Mounting	
	A	B	A	B
Porcelain	5.62 (142)	122.00 (3098)	7.62 (193)	124.00 (3149)
Stainless Steel or Karbate	5.62 (142)	122.00 (3098)	7.62 (193)	124.00 (3149)

Displacer Type	C	D
Porcelain	2.56 (65)	7.25 (184)
Stainless Steel or Karbate	2.50 (63)	9.00 (228)

Electrical Connections
TYPE 4X/7/9, Group B: 1" NPT NEMA 1 Pneumatic: ¼" NPT

STANDARD ACTUATING LEVELS AND LIQUID SPECIFIC GRAVITY

Displacer Type	Liquid Temp. °F	0.50		0.60		0.70		0.80		0.90		1.00	
		E	F	E	F	E	F	E	F	E	F	E	F
Porcelain	100	—	—	5.10 (129)	2.10 (53)	4.50 (114)	1.70 (43)	3.90 (99)	1.70 (43)	3.50 (88)	1.50 (38)	3.20 (81)	1.40 (35)
	200	—	—	5.60 (142)	2.60 (66)	4.90 (124)	2.10 (53)	4.30 (109)	2.10 (53)	3.80 (96)	1.80 (45)	3.50 (88)	1.70 (43)
	300	—	—	—	—	5.20 (132)	2.40 (60)	4.50 (114)	2.30 (58)	4.10 (104)	2.10 (53)	3.70 (93)	1.90 (48)
	400	—	—	—	—	5.60 (142)	2.80 (71)	4.80 (121)	2.60 (66)	4.30 (109)	2.30 (58)	3.90 (99)	2.10 (53)
	500	—	—	—	—	—	—	5.10 (129)	2.90 (73)	4.60 (116)	2.60 (66)	4.20 (106)	2.40 (60)
Stainless Steel or Karbate	100	5.40 (137)	2.00 (50)	4.50 (114)	1.60 (40)	3.90 (99)	1.40 (35)	3.40 (86)	1.20 (30)	3.00 (76)	1.10 (27)	2.70 (68)	1.00 (25)
	200	6.00 (152)	2.60 (66)	5.00 (127)	2.10 (53)	4.30 (109)	1.80 (45)	3.70 (93)	1.60 (40)	3.30 (83)	1.40 (35)	3.00 (76)	1.30 (33)
	300	6.40 (162)	3.00 (76)	5.30 (134)	2.40 (60)	4.60 (116)	2.10 (53)	4.00 (101)	1.80 (45)	3.60 (91)	1.70 (43)	3.20 (81)	1.50 (38)
Stainless Steel	400	6.90 (175)	3.50 (88)	5.70 (144)	2.80 (71)	4.90 (124)	2.40 (60)	4.30 (109)	2.10 (53)	3.80 (96)	1.90 (48)	3.40 (86)	1.70 (43)
	500	—	—	6.10 (154)	3.20 (81)	5.20 (132)	2.80 (71)	4.60 (116)	2.40 (60)	4.10 (104)	2.20 (55)	3.70 (93)	2.00 (50)

Note: All levels ±0.25" (6).

*See page 21 for proof-er and/or floating roof top switch dimensions.

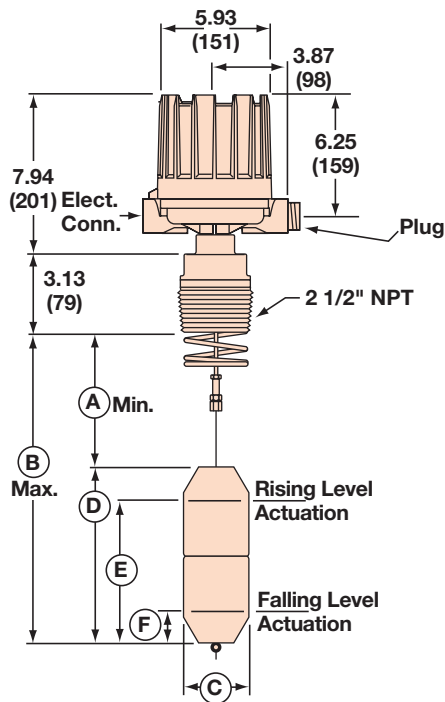

Model A15
with Threaded Mounting

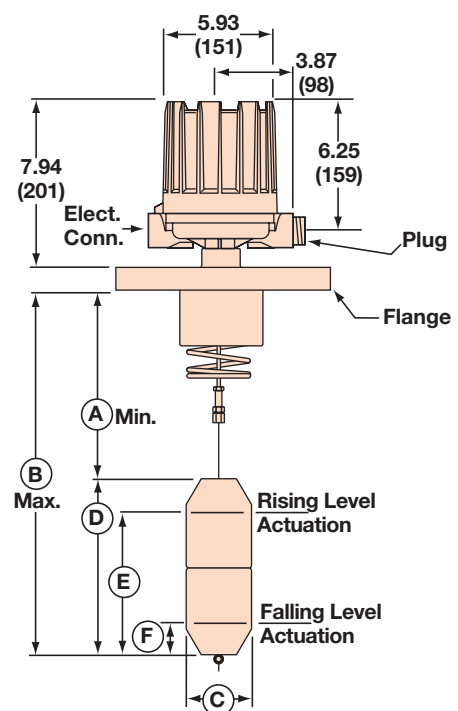

Model A15
with Flanged Mounting

SPECIFICATIONS

MODEL B10 DIMENSIONAL DATA

INCHES (MM)

Outline Dimensions				
Displacer Type	Threaded Mounting		Flanged Mounting	
	A	B	A	B
Porcelain	4.88 (123)	122.00 (3098)	6.88 (174)	124.00 (3149)
Stainless Steel or Karbate	4.75 (120)	122.00 (3098)	6.75 (171)	124.00 (3149)

MODEL B10 WITH DISPLACER ARRANGEMENTS 3, 4, AND 5

Displacer Type	C	D	E	F
Porcelain	2.56 (65)	5.02 (127)	5.02 (127)	5.02 (127)
Stainless Steel or Karbate	2.50 (63)	6.00 (152)	6.00 (152)	6.00 (152)

MODEL B10 WITH DISPLACER ARRANGEMENTS 1 AND 2

Displacer Type	C	D	E
Porcelain	2.56 (65)	10.04 (255)	5.02 (127)
Stainless Steel or Karbate	2.50 (63)	12.00 (304)	6.00 (152)

Electrical Connections

TYPE 4X/7/9
Group B: 1" NPT

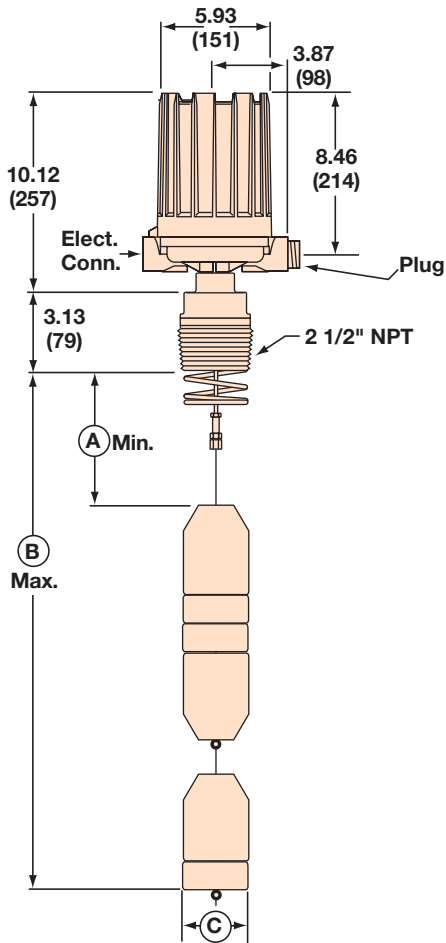

Model B10
with Threaded Mounting

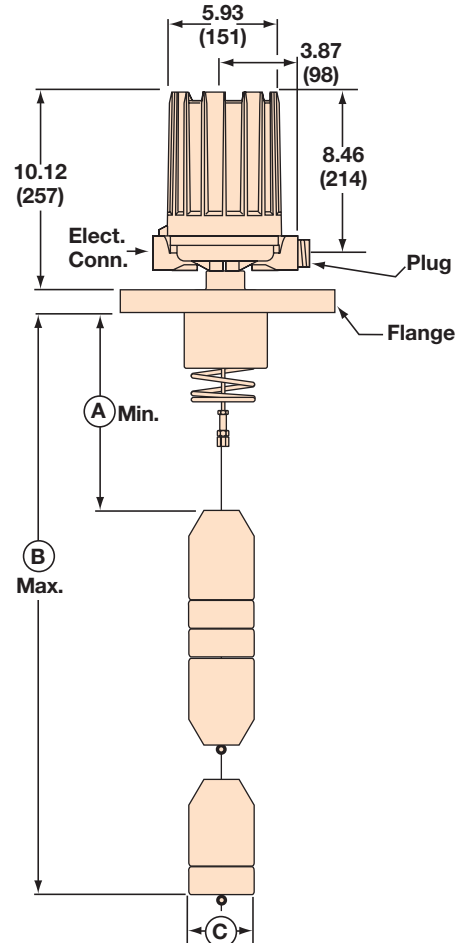

Model B10
with Flanged Mounting

SPECIFICATIONS

MODEL B10 ACTUATION LEVELS

INCHES (MM)

B10 STANDARD ACTUATING LEVELS AND LIQUID SPECIFIC GRAVITY WITH DISPLACER ARRANGEMENT 1

Displacer Type	Liquid Temp. ° F	Level	0.60 - 0.64	0.65 - 0.71	0.72 - 0.73	0.74 - 0.82	0.83 - 0.92	0.93 - 1.00	1.01 - 1.07
Porcelain	100	F	7.79 - 7.04 (197 - 178)	7.66 - 6.65 (194 - 168)	7.22 - 7.06 (183 - 179)	6.91 - 5.81 (175 - 147)	6.73 - 5.65 (180 - 143)	5.55 - 4.86 (140 - 123)	4.97 - 4.53 (126 - 115)
		G	2.62 - 2.19 (56 - 55)	2.88 - 2.28 (73 - 57)	2.91 - 2.81 (73 - 71)	2.71 - 2.03 (68 - 51)	2.99 - 2.28 (75 - 57)	2.21 - 1.76 (56 - 44)	1.90 - 1.63 (48 - 41)
		H	2.01 - 1.89 (51 - 48)	1.86 - 1.70 (47 - 43)	1.68 - 1.65 (42 - 41)	1.63 - 1.47 (41 - 37)	1.45 - 1.31 (36 - 33)	1.30 - 1.21 (33 - 30)	1.02 - 0.97 (25 - 24)
	200	F	7.91 (200)	7.72 - 6.71 (196 - 170)	6.56 - 6.41 (166 - 162)	6.73 - 5.66 (170 - 143)	6.37 - 5.33 (161 - 135)	6.15 - 5.42 (156 - 137)	5.02 - 4.57 (127 - 116)
		G	3.06 (77)	2.95 - 2.34 (74 - 59)	2.25 - 2.16 (57 - 54)	2.54 - 1.87 (64 - 47)	2.63 - 1.95 (66 - 49)	2.81 - 2.32 (71 - 58)	1.94 - 1.67 (49 - 42)
		H	2.76 (70)	2.72 - 2.49 (69 - 63)	2.45 - 2.42 (62 - 61)	2.39 - 2.15 (60 - 54)	2.13 - 1.92 (54 - 48)	1.90 - 1.77 (48 - 44)	1.58 - 1.49 (40 - 37)
	300	F	—	—	—	7.48 - 6.34 (189 - 161)	7.04 - 5.93 (178 - 150)	6.75 - 5.98 (171 - 151)	5.57 - 5.10 (141 - 129)
		G	—	—	—	3.29 - 2.55 (83 - 64)	3.30 - 2.56 (83 - 65)	3.41 - 2.87 (86 - 72)	2.50 - 2.19 (63 - 55)
		H	—	—	—	3.14 - 2.83 (79 - 71)	2.80 - 2.53 (71 - 64)	2.50 - 2.32 (63 - 58)	2.13 - 2.01 (54 - 51)
	400	F	—	—	—	—	—	—	6.12 - 5.62 (155 - 142)
		G	—	—	—	—	—	—	3.05 - 2.72 (77 - 69)
		H	—	—	—	—	—	—	2.68 - 2.53 (68 - 64)

Note: All levels ±0.25" (6).

Displacer Type	Liquid Temp. ° F	Level	1.08 - 1.12	1.13 - 1.17	1.18 - 1.27	1.28 - 1.30	1.31 - 1.39	1.40 - 1.50
Porcelain	100	F	4.47 - 4.20 (113 - 106)	4.90 - 4.64 (124 - 117)	4.57 - 4.05 (116 - 102)	3.99 - 3.89 (101 - 98)	4.23 - 3.82 (107 - 97)	3.77 - 3.33 (95 - 84)
		G	1.59 - 1.43 (40 - 36)	2.16 - 1.99 (54 - 50)	1.94 - 1.60 (49 - 40)	1.57 - 1.50 (39 - 38)	1.86 - 1.59 (47 - 40)	1.56 - 1.26 (39 - 32)
		H	0.96 - 0.92 (24 - 23)	0.92 - 0.88 (23 - 22)	0.88 - 0.81 (22 - 20)	0.81 - 0.80 (20 - 20)	0.79 - 0.74 (20 - 18)	0.74 - 0.69 (18 - 17)
	200	F	4.66 - 4.39 (118 - 111)	4.33 - 4.08 (109 - 103)	4.32 - 3.81 (109 - 96)	4.29 - 4.18 (108 - 106)	4.13 - 3.73 (104 - 94)	3.93 - 3.47 (99 - 88)
		G	1.79 - 1.62 (45 - 41)	1.58 - 1.43 (40 - 36)	1.69 - 1.36 (42 - 34)	1.87 - 1.80 (47 - 45)	1.76 - 1.49 (44 - 37)	1.71 - 1.40 (43 - 35)
		H	1.48 - 1.42 (37 - 36)	1.41 - 1.36 (35 - 34)	1.35 - 1.25 (34 - 31)	1.24 - 1.23 (31 - 31)	1.22 - 1.15 (30 - 29)	1.14 - 1.06 (28 - 26)
	300	F	5.18 - 4.89 (131 - 124)	4.82 - 4.56 (122 - 115)	4.79 - 4.25 (121 - 107)	4.73 - 4.61 (120 - 117)	4.56 - 4.13 (115 - 104)	4.32 - 3.84 (109 - 97)
		G	2.31 - 2.12 (58 - 53)	2.08 - 1.91 (52 - 48)	2.16 - 1.80 (54 - 45)	2.31 - 2.23 (58 - 56)	2.19 - 1.90 (55 - 48)	2.11 - 1.78 (53 - 45)
		H	1.99 - 1.92 (50 - 48)	1.90 - 1.84 (48 - 46)	1.82 - 1.69 (45 - 42)	1.68 - 1.66 (42 - 42)	1.64 - 1.55 (41 - 39)	1.54 - 1.43 (39 - 36)
	400	F	5.70 - 5.39 (144 - 136)	5.32 - 5.04 (135 - 128)	5.26 - 4.69 (133 - 119)	5.17 - 5.04 (131 - 128)	4.98 - 4.53 (126 - 115)	4.72 - 4.22 (119 - 107)
		G	2.82 - 2.62 (71 - 66)	2.57 - 2.39 (65 - 60)	2.63 - 2.24 (66 - 56)	2.74 - 2.66 (69 - 67)	2.61 - 2.30 (66 - 58)	2.51 - 2.15 (63 - 54)
		H	2.51 - 2.42 (63 - yt61)	2.40 - 2.32 (60 - 58)	2.30 - 2.13 (58 - 54)	2.12 - 2.08 (53 - 52)	2.07 - 1.95 (52 - 49)	1.94 - 1.81 (49 - 45)
500	F	6.22 - 5.89 (157 - 149)	5.81 - 5.52 (147 - 140)	5.74 - 5.13 (145 - 130)	5.60 - 5.47 (142 - 138)	5.41 - 4.93 (137 - 125)	5.12 - 4.59 (130 - 116)	
	G	3.34 - 3.12 (84 - 79)	3.07 - 2.86 (77 - 72)	3.11 - 2.68 (78 - 68)	3.18 - 3.09 (80 - 78)	3.04 - 2.70 (77 - 68)	2.91 - 2.52 (73 - 64)	
	H	3.03 - 2.92 (76 - 74)	2.89 - 2.79 (73 - 70)	2.77 - 2.57 (70 - 65)	2.55 - 2.51 (64 - 63)	2.50 - 2.35 (63 - 59)	2.33 - 2.18 (59 - 55)	

Note: All levels ±0.25" (6).

SPECIFICATIONS

MODEL B10 ACTUATION LEVELS (cont.)

INCHES (MM)

B10 STANDARD ACTUATING LEVELS AND LIQUID SPECIFIC GRAVITY WITH DISPLACER ARRANGEMENT 1 (cont.)

Displacer Type	Liquid Temp. ° F	Level	0.50 - 0.58	0.59 - 0.71	0.72 - 0.79	0.80 - 0.85	0.86 - 1.00	1.01 - 1.03
Stainless Steel and Karbate	100	F	9.91 - 7.72 (251 - 196)	9.19 - 6.62 (233 - 168)	8.44 - 7.16 (214 - 181)	7.66 - 6.86 (194 - 174)	6.71 - 4.93 (170 - 125)	4.82 - 4.61 (122 - 117)
		G	3.46 - 2.16 (86 - 54)	3.72 - 2.08 (94 - 52)	3.96 - 3.07 (100 - 77)	3.63 - 3.07 (92 - 77)	2.96 - 1.71 (75 - 43)	1.63 - 1.48 (41 - 37)
		H	2.51 - 2.16 (63 - 54)	2.13 - 1.77 (54 - 44)	1.74 - 1.59 (44 - 40)	1.57 - 1.48 (39 - 37)	1.46 - 1.25 (37 - 31)	1.24 - 1.22 (31 - 30)
	200	F	10.22 - 7.98 (259 - 202)	7.74 - 7.44 (196 - 188)	7.50 - 6.30 (190 - 160)	6.15 - 5.44 (156 - 138)	6.97 - 5.15 (177 - 130)	—
		G	3.76 - 2.42 (95 - 61)	2.27 - 1.89 (57 - 48)	3.02 - 2.22 (76 - 56)	2.12 - 1.64 (53 - 41)	3.22 - 1.93 (81 - 49)	—
		H	3.67 - 3.16 (93 - 80)	3.11 - 2.58 (78 - 65)	2.55 - 2.32 (64 - 58)	2.29 - 2.16 (58 - 54)	2.13 - 1.84 (54 - 46)	—
	300	F	—	9.68 - 7.25 (245 - 184)	8.31 - 7.04 (211 - 178)	6.88 - 6.12 (174 - 155)	7.65 - 5.73 (194 - 145)	—
		G	—	4.30 - 2.70 (109 - 68)	3.83 - 2.96 (97 - 75)	2.84 - 2.32 (72 - 58)	3.89 - 2.51 (98 - 63)	—
		H	—	4.03 - 3.40 (102 - 86)	3.36 - 3.06 (85 - 77)	3.02 - 2.84 (76 - 72)	2.81 - 2.42 (71 - 61)	—
Stainless Steel	400	F	—	—	9.11 - 7.77 (231 - 197)	7.60 - 6.80 (193 - 172)	8.32 - 6.32 (211 - 160)	—
		G	—	—	4.63 - 3.69 (117 - 93)	3.57 - 3.01 (90 - 76)	4.57 - 3.09 (116 - 78)	—
		H	—	—	4.16 - 3.79 (105 - 96)	3.75 - 3.53 (95 - 89)	3.48 - 3.00 (88 - 76)	—
	500	F	—	—	—	—	9.00 - 6.90 (228 - 175)	—
		G	—	—	—	—	5.24 - 3.67 (133 - 93)	—
		H	—	—	—	—	4.16 - 3.58 (105 - 90)	—

Note: All levels $\pm 0.25"$ (6).

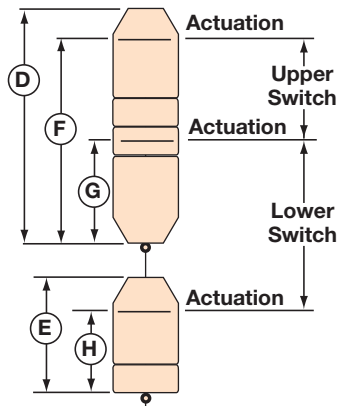

**Model B10
Displacer Arrangement 1**

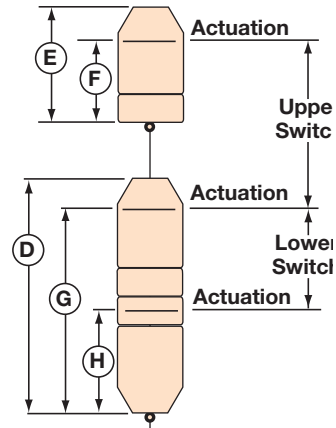

**Model B10
Displacer Arrangement 2**

SPECIFICATIONS

MODEL B10 ACTUATION LEVELS (cont.)

INCHES (MM)

B10 STANDARD ACTUATING LEVELS AND LIQUID SPECIFIC GRAVITY WITH DISPLACER ARRANGEMENT 2

Displacer Type	Liquid Temp. ° F	Level	0.60 - 0.64	0.65 -0.71	0.72 - 0.73	0.74 - 0.82	0.83 - 0.92	0.93 - 1.00	1.01 - 1.07
Porcelain	100	F	2.77 - 2.01 (70 - 51)	2.63 - 1.62 (66 - 41)	2.67 - 2.51 (67 - 63)	2.58 - 1.42 (65 - 36)	3.16 - 1.94 (80 - 49)	1.82 - 1.04 (45 - 26)	1.69 - 1.23 (42 - 31)
		G	7.27 - 6.84 (184 - 173)	7.54 - 6.93 (191 - 176)	7.56 - 7.46 (192 - 189)	7.36 - 6.68 (186 - 169)	7.64 - 6.93 (194 - 176)	6.86 - 6.41 (174 - 162)	5.15 - 4.89 (130 - 124)
		H	2.67 - 2.53 (67 - 64)	3.29 - 3.05 (83 - 77)	3.73 - 3.68 (94 - 93)	3.64 - 3.32 (92 - 84)	4.32 - 3.93 (109 - 99)	3.90 - 3.65 (99 - 92)	2.42 - 2.31 (61 - 58)
	200	F	3.15 (80)	2.96 - 1.93 (75 - 49)	1.77 - 1.62 (44 - 41)	2.64 - 1.47 (67 - 37)	2.79 - 1.61 (70 - 40)	2.79 - 1.94 (70 - 49)	1.56 - 1.11 (39 - 28)
		G	7.71 (195)	7.60 - 6.99 (193 - 177)	6.90 - 6.81 (175 - 172)	7.19 - 6.52 (182 - 165)	7.28 - 6.60 (184 - 167)	7.46 - 6.97 (189 - 177)	5.19 - 4.92 (131 - 124)
		H	3.40 (86)	3.36 - 3.10 (85 - 78)	3.07 - 3.03 (77 - 76)	3.46 - 3.16 (87 - 80)	3.96 - 3.61 (100 - 91)	4.50 - 4.21 (114 - 106)	2.46 - 2.35 (62 - 59)
	300	F	—	—	—	3.39 - 2.15 (86 - 54)	3.47 - 2.22 (88 - 56)	3.39 - 2.50 (86 - 63)	2.11 - 1.63 (53 - 41)
		G	—	—	—	7.94 - 7.20 (201 - 182)	7.95 - 7.21 (201 - 183)	8.06 - 7.53 (204 - 191)	5.75 - 5.45 (146 - 138)
		H	—	—	—	4.21 - 3.84 (106 - 97)	4.63 - 4.21 (117 - 106)	5.10 - 4.77 (129 - 121)	3.02 - 2.87 (76 - 72)
	400	F	—	—	—	—	—	—	2.67 - 2.15 (67 - 54)
		G	—	—	—	—	—	—	6.30 - 5.97 (160 - 151)
		H	—	—	—	—	—	—	3.57 - 3.39 (90 - 86)

Displacer Type	Liquid Temp. ° F	Level	1.08 - 1.12	1.13 - 1.17	1.18 - 1.27	1.28 - 1.30	1.31 - 1.39	1.40 - 1.50
Porcelain	100	F	1.16 - 0.89 (29 - 22)	2.04 - 1.75 (51 - 44)	1.68 - 1.10 (42 - 27)	1.04 - 0.92 (26 - 23)	2.05 - 1.56 (52 - 39)	1.50 - 0.97 (38 - 24)
		G	4.84 - 4.68 (122 - 118)	5.41 - 5.24 (137 - 133)	5.20 - 4.85 (132 - 123)	4.82 - 4.75 (122 - 120)	5.11 - 4.84 (129 - 122)	4.81 - 4.51 (122 - 114)
		H	2.29 - 2.22 (58 - 56)	2.97 - 2.88 (75 - 73)	2.86 - 2.68 (72 - 68)	2.66 - 2.63 (67 - 66)	3.01 - 2.85 (76 - 72)	2.84 - 2.67 (72 - 67)
	200	F	1.68 - 1.38 (42 - 35)	1.31 - 1.05 (33 - 26)	1.71 - 1.13 (43 - 28)	1.75 - 1.62 (44 - 41)	1.56 - 1.09 (39 - 27)	1.53 - 1.00 (38 - 25)
		G	5.04 - 4.88 (128 - 123)	4.84 - 4.68 (122 - 118)	4.94 - 4.62 (125 - 117)	5.12 - 5.05 (130 - 128)	5.01 - 4.75 (127 - 120)	4.96 - 4.65 (125 - 118)
		H	2.49 - 2.41 (63 - 61)	2.39 - 2.33 (60 - 59)	2.60 - 2.44 (66 - 61)	2.97 - 2.93 (73 - 70)	2.91 - 2.76 (73 - 70)	2.99 - 2.82 (75 - 77)
	300	F	2.19 - 1.88 (55 - 47)	1.81 - 1.52 (45 - 38)	2.19 - 1.57 (55 - 39)	2.18 - 2.05 (50 - 37)	1.98 - 1.49 (50 - 37)	1.93 - 1.37 (49 - 34)
		G	5.56 - 5.37 (141 - 136)	5.33 - 5.16 (135 - 131)	5.41 - 5.06 (137 - 128)	5.56 - 5.48 (138 - 130)	5.44 - 5.15 (138 - 130)	5.36 - 5.03 (136 - 127)
		H	3.01 - 2.91 (76 - 73)	2.89 - 2.80 (73 - 71)	3.07 - 2.88 (77 - 73)	3.40 - 3.36 (84 - 80)	3.33 - 3.16 (84 - 80)	3.39 - 3.19 (86 - 81)
	400	F	2.71 - 2.38 (68 - 60)	2.30 - 2.00 (58 - 50)	2.66 - 2.01 (67 - 51)	2.62 - 2.48 (61 - 48)	2.41 - 1.90 (61 - 48)	2.33 - 1.74 (59 - 44)
		G	6.08 - 5.87 (154 - 149)	5.82 - 5.64 (147 - 143)	5.89 - 5.49 (149 - 139)	5.99 - 5.91 (152 - 150)	5.87 - 5.55 (149 - 140)	5.76 - 5.40 (146 - 137)
		H	3.52 - 3.41 (89 - 86)	3.38 - 3.28 (85 - 83)	3.55 - 3.32 (90 - 84)	3.84 - 3.79 (97 - 96)	3.76 - 3.56 (95 - 90)	3.79 - 3.56 (96 - 90)
	500	F	3.23 - 2.88 (82 - 73)	2.80 - 2.48 (71 - 62)	3.13 - 2.45 (79 - 62)	3.05 - 2.91 (77 - 73)	2.84 - 2.30 (72 - 58)	2.73 - 2.11 (69 - 53)
		G	6.59 - 6.37 (167 - 161)	6.32 - 6.12 (160 - 155)	6.36 - 5.93 (161 - 150)	6.43 - 6.34 (163 - 161)	6.29 - 5.95 (159 - 151)	6.16 - 5.77 (156 - 146)
		H	4.04 - 3.91 (102 - 99)	3.88 - 3.76 (98 - 95)	4.02 - 3.76 (102 - 95)	4.28 - 4.21 (108 - 106)	4.19 - 3.97 (106 - 100)	4.19 - 3.93 (106 - 99)

Note: All levels ±0.25" (6).

SPECIFICATIONS

MODEL B10 ACTUATION LEVELS (cont.)

INCHES (MM)

B10 STANDARD ACTUATING LEVELS AND LIQUID SPECIFIC GRAVITY WITH DISPLACER ARRANGEMENT 2 (cont.)

Displacer Type	Liquid Temp. ° F	Level	0.50 - 0.58	0.59 - 0.71	0.72 - 0.79	0.80 - 0.85	0.86 - 1.00	1.01 - 1.03
Stainless Steel and Karbate	100	F	3.77 - 1.60 (95 - 40)	4.10 - 1.38 (104 - 35)	4.43 - 2.97 (112 - 75)	4.58 - 3.60 (24 - 91)	3.42 - 1.26 (86 - 31)	1.13 - 0.88 (28 - 22)
		G	9.46 - 8.16 (240 - 207)	9.72 - 8.08 (246 - 205)	9.96 - 9.07 (252 - 230)	9.63 - 9.07 (244 - 230)	8.96 - 7.71 (227 - 195)	7.63 - 7.48 (193 - 189)
		H	3.73 - 3.21 (94 - 81)	4.86 - 4.04 (123 - 102)	5.97 - 5.44 (151 - 138)	6.05 - 5.69 (153 - 144)	5.63 - 4.84 (143 - 122)	4.79 - 4.70 (121 - 119)
	200	F	4.22 - 1.98 (107 - 50)	1.74 - 1.44 (44 - 36)	3.74 - 2.35 (94 - 59)	2.17 - 1.33 (55 - 33)	3.89 - 1.66 (98 - 42)	—
		G	9.76 - 8.42 (247 - 213)	8.27 - 6.88 (210 - 174)	9.02 - 8.22 (229 - 208)	8.12 - 7.64 (206 - 194)	9.22 - 7.93 (234 - 201)	—
		H	4.03 - 3.47 (102 - 88)	3.41 - 2.84 (86 - 62)	5.04 - 4.59 (128 - 116)	4.53 - 4.27 (115 - 108)	5.88 - 5.06 (149 - 128)	—
	300	F	—	4.87 - 2.26 (123 - 57)	4.55 - 3.08 (115 - 78)	2.89 - 2.02 (73 - 51)	4.56 - 2.24 (115 - 56)	—
		G	—	10.30 - 8.70 (261 - 220)	9.83 - 8.96 (249 - 227)	8.84 - 8.32 (224 - 211)	9.89 - 8.51 (251 - 216)	—
		H	—	5.52 - 4.66 (140 - 118)	5.84 - 5.33 (148 - 135)	5.26 - 4.95 (133 - 125)	6.56 - 5.64 (166 - 131)	—
Stainless Steel	400	F	—	—	5.35 - 3.82 (135 - 97)	3.62 - 2.70 (91 - 68)	5.24 - 2.82 (133 - 71)	—
		G	—	—	10.63 - 9.69 (270 - 246)	9.57 - 9.01 (243 - 228)	10.57 - 9.09 (183 - 157)	—
		H	—	—	6.65 - 6.06 (168 - 153)	5.99 - 5.63 (152 - 143)	7.24 - 6.22 (183 - 157)	—
	500	F	—	—	—	—	5.91 - 3.41 (150 - 86)	—
		G	—	—	—	—	11.24 - 9.67 (285 - 245)	—
		H	—	—	—	—	7.91 - 6.80 (200 - 172)	—

Note: All levels ±0.25" (6).

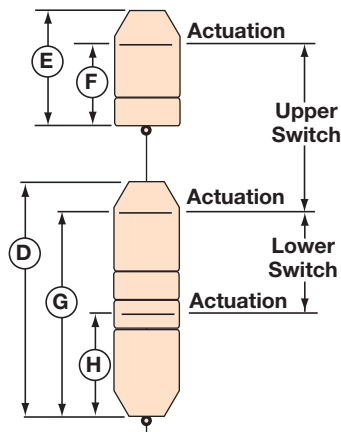

**Model B10
Displacer Arrangement 2**

SPECIFICATIONS

MODEL B10 ACTUATION LEVELS (cont.)

INCHES (MM)

B10 STANDARD ACTUATING LEVELS AND LIQUID SPECIFIC GRAVITY WITH DISPLACER ARRANGEMENTS 3, 4, AND 5

Displacer Type	Liquid Temp. °F	Level	0.60 - 0.64	0.65 - 0.71	0.72 - 0.73	0.74 - 0.82	0.83 - 0.92	0.93 - 1.00	1.01 - 1.07
Porcelain	100	G	2.77 - 2.01 (70 - 51)	2.63 - 1.62 (66 - 41)	2.67 - 2.51 (67 - 63)	2.58 - 1.42 (65 - 36)	3.16 - 1.94 (80 - 49)	1.82 - 1.04 (45 - 26)	1.69 - 1.23 (42 - 31)
		H	2.24 - 1.81 (56 - 45)	2.51 - 1.90 (63 - 48)	2.53 - 2.43 (64 - 61)	2.34 - 1.66 (59 - 42)	2.62 - 1.91 (66 - 48)	1.84 - 1.38 (46 - 35)	1.53 - 1.26 (38 - 32)
		J	2.01 - 1.89 (51 - 48)	1.86 - 1.70 (47 - 43)	1.68 - 1.65 (42 - 41)	1.63 - 1.47 (41 - 37)	1.45 - 1.31 (36 - 33)	1.30 - 1.21 (33 - 30)	1.02 - .097 (25 - 24)
	200	G	3.15 (80)	2.96 - 1.93 (75 - 49)	1.77 - 1.62 (44 - 41)	2.64 - 1.47 (67 - 37)	2.79 - 1.61 (70 - 40)	2.79 - 1.94 (70 - 49)	1.56 - 1.11 (39 - 28)
		H	2.69 (68)	2.57 - 1.96 (965 - 49)	1.87 - 1.78 (47 - 45)	2.16 - 1.50 (54 - 38)	2.25 - 1.58 (57 - 40)	2.44 - 1.94 (61 - 49)	1.40 - 1.14 (35 - 28)
		J	2.76 (70)	2.72 - 2.49 (69 - 63)	2.45 - 2.42 (62 - 61)	2.39 - 2.15 (60 - 54)	2.13 - 1.92 (54 - 48)	1.90 - 1.77 (48 - 44)	1.58 - 1.49 (40 - 37)
	300	G	—	—	—	3.39 - 2.15 (86 - 54)	3.47 - 2.22 (88 - 56)	3.39 - 2.50 (86 - 63)	2.11 - 1.63 (53 - 41)
		H	—	—	—	2.92 - 2.18 (74 - 55)	2.93 - 2.18 (74 - 55)	3.04 - 2.50 (77 - 63)	1.95 - 1.66 (49 - 42)
		J	—	—	—	3.14 - 2.83 (79 - 71)	2.80 - 2.53 (71 - 64)	2.50 - 2.32 (63 - 58)	2.13 - 2.01 (54 - 51)
	400	G	—	—	—	—	—	—	2.67 - 2.15 (67 - 54)
		H	—	—	—	—	—	—	2.68 - 2.34 (68 - 59)
		J	—	—	—	—	—	—	2.68 - 2.53 (68 - 64)

Note: All levels ±0.25" (6).

Displacer Type	Liquid Temp. °F	Level	1.08 - 1.12	1.13 - 1.17	1.18 - 1.27	1.28 - 1.30	1.31 - 1.39	1.40 - 1.50
Porcelain	100	G	1.16 - 0.89 (29 - 22)	2.04 - 1.75 (51 - 44)	1.68 - 1.10 (42 - 27)	1.04 - 0.92 (26 - 23)	2.05 - 1.56 (52 - 39)	1.50 - 0.97 (38 - 24)
		H	1.22 - 1.06 (30 - 26)	1.78 - 1.61 (45 - 40)	1.57 - 1.23 (39 - 31)	1.19 - 1.12 (30 - 28)	1.49 - 1.21 (37 - 30)	1.18 - 0.89 (29 - 22)
		J	0.96 - 0.92 (24 - 23)	0.92 - 0.88 (23 - 22)	0.88 - 0.81 (22 - 20)	0.81 - 0.80 (20 - 20)	0.79 - 0.74 (20 - 18)	0.74 - 0.69 (18 - 17)
	200	G	1.68 - 1.38 (42 - 35)	1.31 - 1.05 (33 - 26)	1.71 - 1.13 (43 - 28)	1.75 - 1.62 (44 - 41)	1.56 - 1.09 (39 - 27)	1.53 - 1.00 (38 - 25)
		H	1.42 - 1.25 (36 - 31)	1.21 - 1.06 (30 - 26)	1.31 - 0.99 (33 - 25)	1.50 - 1.42 (38 - 36)	1.39 - 1.12 (35 - 28)	1.33 - 1.03 (33 - 26)
		J	1.48 - 1.42 (37 - 36)	1.41 - 1.36 (35 - 34)	1.35 - 1.25 (34 - 31)	1.24 - 1.23 (31 - 31)	1.22 - 1.15 (30 - 29)	1.14 - 1.06 (28 - 26)
	300	G	2.19 - 1.88 (55 - 47)	1.81 - 1.52 (45 - 38)	2.19 - 1.57 (55 - 39)	2.18 - 2.05 (50 - 37)	1.98 - 1.49 (50 - 37)	1.93 - 1.37 (49 - 34)
		H	1.93 - 1.75 (49 - 44)	1.70 - 1.53 (43 - 38)	1.79 - 1.43 (45 - 36)	1.93 - 1.85 (49 - 46)	1.81 - 1.52 (45 - 38)	1.73 - 1.40 (43 - 35)
		J	1.99 - 1.92 (50 - 48)	1.90 - 1.84 (48 - 46)	1.82 - 1.69 (45 - 42)	1.68 - 1.66 (42 - 42)	1.64 - 1.55 (41 - 39)	1.54 - 1.43 (39 - 36)
	400	G	2.71 - 2.38 (68 - 60)	2.30 - 2.00 (58 - 50)	2.66 - 2.01 (67 - 51)	2.62 - 2.48 (61 - 48)	2.41 - 1.90 (61 - 48)	2.33 - 1.74 (59 - 44)
		H	2.45 - 2.25 (62 - 57)	2.20 - 2.01 (55 - 51)	2.26 - 1.87 (57 - 47)	2.37 - 2.28 (60 - 57)	2.24 - 1.92 (56 - 23)	2.13 - 1.77 (54 - 44)
		J	2.51 - 2.42 (63 - 61)	2.40 - 2.32 (60 - 58)	2.30 - 2.13 (58 - 54)	2.12 - 2.08 (53 - 52)	2.07 - 1.95 (52 - 49)	1.94 - 1.81 (49 - 45)
500	G	3.23 - 2.88 (82 - 73)	2.80 - 2.48 (71 - 62)	3.13 - 2.45 (79 - 62)	3.05 - 2.91 (77 - 73)	2.84 - 2.30 (72 - 58)	2.73 - 2.11 (69 - 53)	
	H	2.97 - 2.75 (75 - 69)	2.69 - 2.49 (68 - 63)	2.73 - 2.31 (69 - 58)	2.80 - 2.71 (71 - 68)	2.67 - 2.33 (67 - 59)	2.53 - 2.15 (64 - 54)	
	J	3.03 - 2.92 (76 - 74)	2.89 - 2.79 (73 - 70)	2.77 - 2.57 (70 - 65)	2.55 - 2.51 (64 - 63)	2.50 - 2.35 (63 - 59)	2.33 - 2.18 (59 - 55)	

Note: All levels ±0.25" (6).

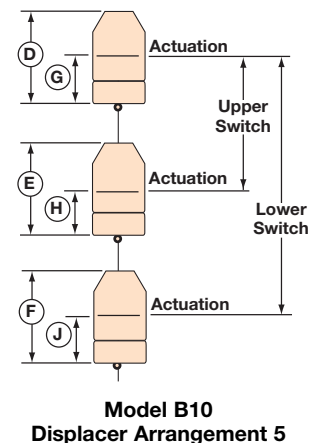
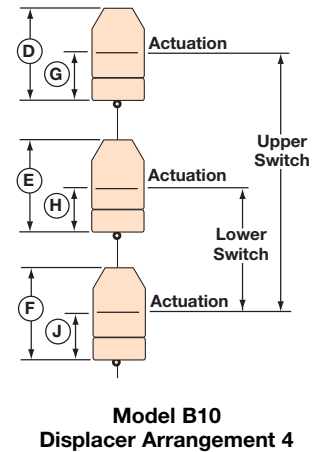
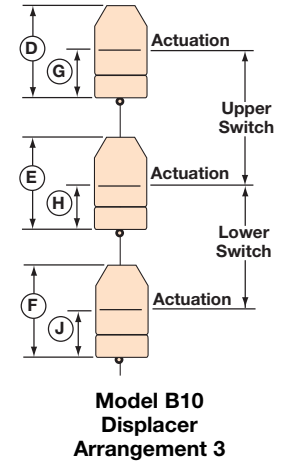

SPECIFICATIONS

MODEL B10 ACTUATION LEVELS (cont.)

INCHES (MM)

B10 STANDARD ACTUATING LEVELS AND LIQUID SPECIFIC GRAVITY WITH DISPLACER ARRANGEMENTS 3, 4, AND 5

Displacer Type	Liquid Temp. ° F	Level	0.50 - 0.58	0.59 - 0.71	0.72 - 0.79	0.80 - 0.85	0.86 - 1.00	1.01 - 1.03
Stainless Steel and Karbate	100	G	3.77 - 1.60 (95 - 40)	4.10 - 1.38 (104 - 35)	4.43 - 2.97 (112 - 75)	4.58 - 3.60 (24 - 91)	3.42 - 1.26 (86 - 31)	1.13 - 0.88 (28 - 22)
		H	3.46 - 2.16 (87 - 54)	3.72 - 2.08 (94 - 52)	3.96 - 3.07 (100 - 77)	3.63 - 3.07 (92 - 77)	2.96 - 1.71 (75 - 43)	1.45 - 1.31 (36 - 33)
		J	2.51 - 2.16 (63 - 54)	2.13 - 1.77 (54 - 44)	1.74 - 1.59 (44 - 40)	1.57 - 1.48 (39 - 37)	1.46 - 1.25 (37 - 31)	1.24 - 1.22 (31 - 30)
	200	G	4.22 - 1.98 (107 - 50)	1.74 - 1.44 (44 - 36)	3.74 - 2.35 (94 - 59)	2.17 - 1.33 (55 - 33)	3.89 - 1.66 (98 - 42)	—
		H	3.76 - 2.42 (95 - 61)	2.27 - 1.89 (57 - 48)	3.02 - 2.22 (76 - 56)	2.12 - 1.64 (53 - 41)	3.22 - 1.93 (81 - 49)	—
		J	3.67 - 3.16 (93 - 80)	3.11 - 2.58 (78 - 65)	2.55 - 2.32 (64 - 58)	2.29 - 2.16 (58 - 54)	2.13 - 1.84 (54 - 46)	—
	300	G	—	4.87 - 2.26 (123 - 57)	4.55 - 3.08 (115 - 78)	2.89 - 2.02 (73 - 51)	4.56 - 2.24 (115 - 56)	—
		H	—	4.30 - 2.70 (109 - 68)	3.83 - 2.96 (97 - 75)	2.84 - 2.32 (72 - 58)	3.89 - 2.51 (98 - 63)	—
		J	—	4.03 - 3.40 (102 - 86)	3.36 - 3.06 (85 - 77)	3.02 - 2.84 (76 - 72)	2.81 - 2.42 (71 - 61)	—
Stainless Steel	400	G	—	—	5.35 - 3.82 (135 - 97)	3.62 - 2.70 (91 - 68)	5.24 - 2.82 (133 - 71)	—
		H	—	—	4.63 - 3.69 (117 - 93)	3.57 - 3.01 (90 - 76)	4.57 - 3.09 (116 - 78)	—
		J	—	—	4.16 - 3.79 (105 - 96)	3.75 - 3.53 (95 - 89)	3.48 - 3.00 (88 - 76)	—
	500	G	—	—	—	—	5.91 - 3.41 (150 - 86)	—
		H	—	—	—	—	5.24 - 3.67 (133 - 93)	—
		J	—	—	—	—	4.16 - 3.58 (105 - 90)	—

Note: All levels $\pm 0.25"$ (6).

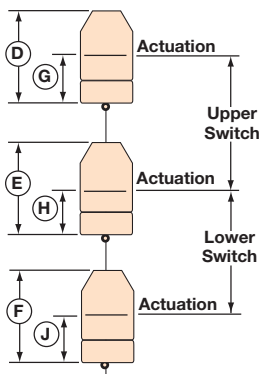

**Model B10
Displacer
Arrangement 3**

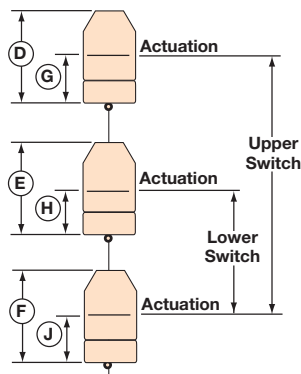

**Model B10
Displacer
Arrangement 4**

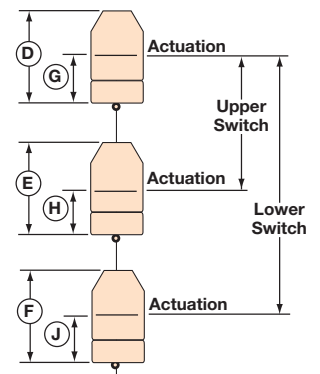

**Model B10
Displacer
Arrangement 5**

SPECIFICATIONS

MODEL B15 DIMENSIONAL DATA AND ACTUATION LEVELS

INCHES (MM)

Outline Dimensions				
Displacer Type	Threaded Mounting		Flanged Mounting	
	A	B	A	B
Porcelain	5.50 (139)	123.00 (3124)	7.50 (190)	125.00 (3175)
Stainless Steel or Karbate	5.88 (149)	123.00 (3121)	7.88 (200)	125.00 (3175)

Displacer Type	C	D	E
Porcelain	2.56 (65)	7.25 (184)	5.02 (127)
Stainless Steel or Karbate	2.50 (63)	10.50 (266)	6.00 (152)

Electrical Connections
TYPE 4X/7/9, Group B: 1" NPT

B15 STANDARD ACTUATING LEVELS AND LIQUID SPECIFIC GRAVITY

Displacer Type	Liquid Temp. °F	0.70				0.80			
		F	G	H	J	F	G	H	J
Stainless Steel or Karbate	100	9.50 (241)	5.00 (127)	4.90 (124)	1.30 (33)	7.60 (193)	3.70 (93)	4.30 (109)	1.10 (27)
	200	—	—	—	—	8.20 (208)	4.30 (109)	5.00 (127)	1.80 (45)

Displacer Type	Liquid Temp. °F	0.95				1.00			
		F	G	H	J	F	G	H	J
Porcelain	100	5.50 (139)	2.00 (50)	3.70 (93)	1.00 (25)	5.00 (127)	1.70 (43)	3.50 (88)	0.80 (20)
Stainless Steel	100	5.50 (139)	2.00 (50)	3.70 (93)	1.00 (25)	4.90 (124)	1.70 (43)	3.40 (86)	0.90 (22)
	200	6.00 (152)	2.70 (68)	4.20 (106)	1.50 (38)	5.40 (137)	2.20 (55)	4.00 (101)	1.50 (38)
	300	6.40 (162)	3.10 (78)	4.70 (119)	2.00 (50)	5.70 (144)	2.50 (63)	4.40 (111)	1.90 (48)
	400	—	—	—	—	6.10 (154)	2.90 (73)	4.90 (124)	2.40 (60)
Karbate	100	5.50 (139)	2.00 (50)	3.70 (93)	1.00 (25)	4.90 (124)	1.70 (43)	3.40 (86)	0.90 (22)
	200	6.00 (152)	2.70 (68)	4.20 (106)	1.50 (38)	5.40 (137)	2.20 (55)	4.00 (101)	1.50 (38)
	300	6.40 (162)	3.10 (78)	4.70 (119)	2.00 (50)	5.70 (144)	2.50 (63)	4.40 (111)	1.90 (48)

Note: All levels ±0.25" (6).

See page 21 for Proof-er and/or Floating roof top switch dimensions.

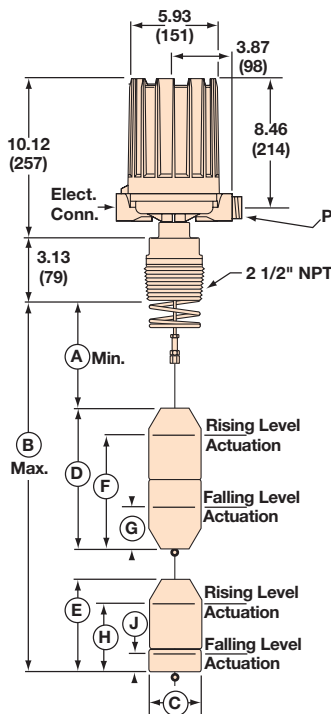

**Model B15
with Threaded Mounting**

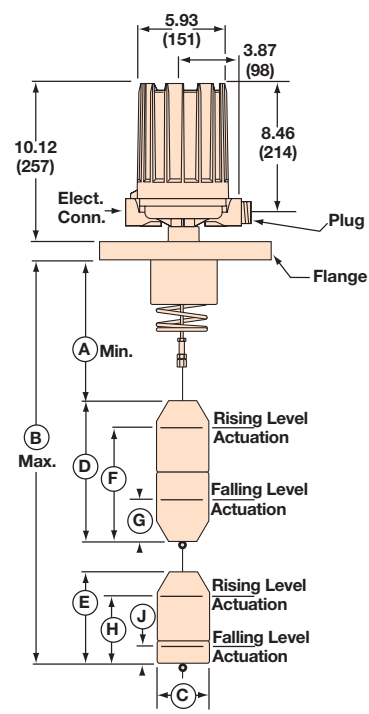

**Model B15
with Flanged Mounting**

SPECIFICATIONS

MODEL C10 DIMENSIONAL DATA

INCHES (MM)

MODEL C10 WITH ALL DISPLACER ARRANGEMENTS

Outline Dimensions				
Displacer Type	Threaded Mounting		Flanged Mounting	
	A	B	A	B
Porcelain	6.38 (965)	123.00 (3124)	8.38 (212)	125.00 (3175)
Stainless Steel or Karbate	5.75 (146)	123.00 (3124)	7.75 (196)	125.00 (3175)

MODEL C10 WITH DISPLACER ARRANGEMENTS A, B, AND C

Displacer Type	C	D	E	F	G
Porcelain	2.56 (65)	6.42 (163)	5.02 (127)	5.02 (127)	3.62 (91)
Stainless Steel or Karbate	2.50 (63)	6.00 (152)	6.00 (152)	4.50 (114)	4.50 (114)

MODEL C10 WITH DISPLACER ARRANGEMENTS D AND F

Displacer Type	C	D	E	F
Porcelain	2.56 (65)	14.44 (367)	5.02 (127)	3.62 (91)
Stainless Steel or Karbate	2.50 (63)	12.00 (304)	4.50 (114)	4.50 (114)

MODEL C10 WITH DISPLACER ARRANGEMENTS E AND G

Displacer Type	C	D	E	F
Porcelain	2.56 (65)	6.42 (153)	5.02 (127)	8.65 (219)
Stainless Steel or Karbate	2.50 (63)	6.00 (152)	6.00 (152)	9.00 (228)

Electrical Connections

TYPE 4X/7/9, Group B: 1" NPT

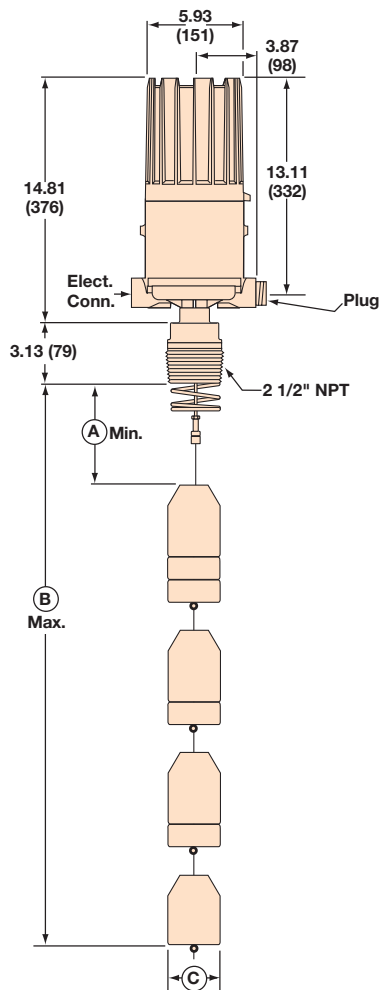

Model C10
with Threaded Mounting

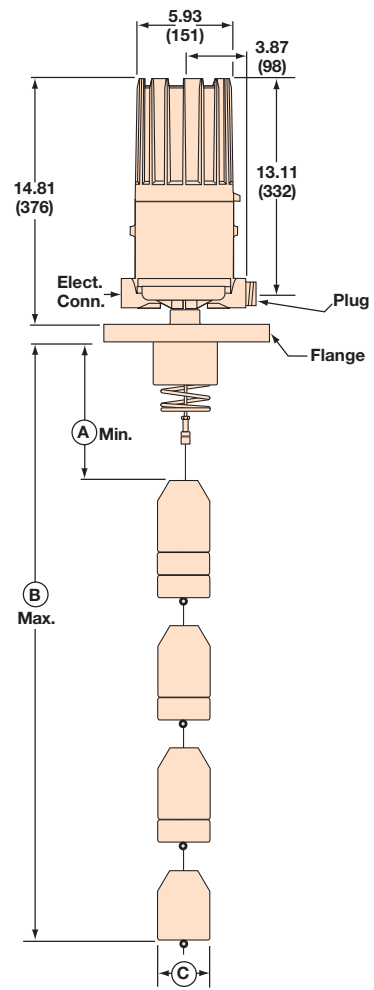

Model C10
with Flanged Mounting

SPECIFICATIONS

MODEL C10 ACTUATION LEVELS (cont.)

INCHES (MM)

C10 STANDARD ACTUATING LEVELS AND LIQUID SPECIFIC GRAVITY WITH DISPLACER ARRANGEMENTS A, B, AND C

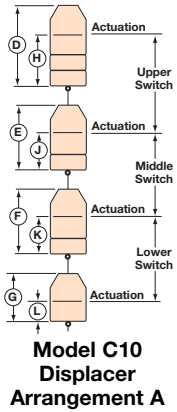

Displacer Type	Liquid Temp. ° F (° C)	0.58				0.60				0.70				0.80			
		H	J	K	L	H	J	K	L	H	J	K	L	H	J	K	L
Porcelain	100 (37.8)	—	—	—	—	—	—	—	—	2.5 (64)	2.2 (56)	2.2 (56)	2.0 (51)	2.3 (58)	2.0 (51)	1.9 (48)	1.7 (43)
	200 (93)	—	—	—	—	—	—	—	—	—	—	—	—	—	—	—	—
Stainless Steel or Karbate	100 (37.8)	4.5 (114)	3.7 (94)	3.2 (81)	2.3 (58)	3.8 (97)	3.2 (81)	3.0 (76)	2.2 (56)	4.2 (107)	3.8 (97)	2.1 (53)	1.9 (48)	1.8 (46)	2.2 (56)	1.3 (33)	1.7 (43)
	200 (93)	—	—	—	—	—	—	—	—	—	—	—	—	3.2 (81)	2.9 (74)	2.5 (64)	2.3 (58)
	300 (149)	—	—	—	—	—	—	—	—	—	—	—	—	—	—	—	—

Note: All levels ±0.25" (6).

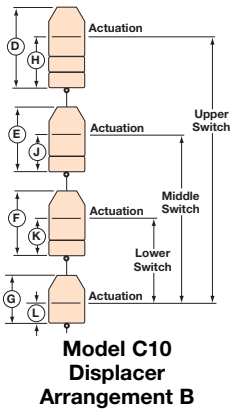

Displacer Type	Liquid Temp. ° F (° C)	0.90				1.00				1.10				1.20			
		H	J	K	L	H	J	K	L	H	J	K	L	H	J	K	L
Porcelain	100 (37.8)	3.0 (76)	2.4 (61)	2.7 (69)	1.5 (38)	1.4 (36)	1.4 (36)	2.1 (53)	1.4 (36)	3.0 (76)	2.6 (66)	2.5 (64)	1.2 (30)	1.7 (43)	1.7 (43)	2.1 (53)	1.1 (28)
	200 (93)	—	—	—	—	3.2 (157)	2.7 (78)	2.8 (71)	1.7 (43)	1.7 (132)	1.7 (53)	2.3 (58)	1.6 (40)	—	—	—	—
Stainless Steel or Karbate	100 (37.8)	3.1 (79)	3.2 (81)	2.5 (64)	1.5 (38)	1.3 (33)	1.9 (48)	1.8 (45)	1.3 (33)	3.1 (79)	3.2 (81)	2.5 (64)	1.3 (33)	1.6 (41)	2.2 (56)	1.9 (48)	1.2 (30)
	200 (93)	3.6 (91)	3.6 (91)	1.7 (43)	2.0 (51)	1.7 (43)	2.3 (58)	1.1 (27)	1.8 (46)	—	—	—	—	—	—	—	—
	300 (149)	3.4 (86)	3.0 (76)	2.4 (61)	2.7 (69)	1.6 (41)	1.8 (46)	1.7 (43)	2.4 (61)	—	—	—	—	—	—	—	—

Note: All levels ±0.25" (6).

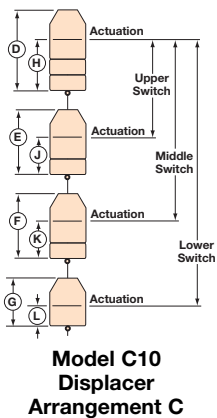

SPECIFICATIONS

MODEL C10 ACTUATION LEVELS (cont.)

INCHES (MM)

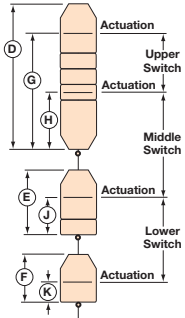

**Model C10
Displacer
Arrangement D**

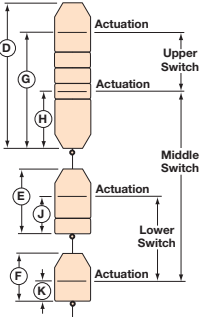

**Model C10
Displacer
Arrangement F**

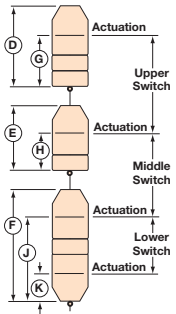

**Model C10
Displacer
Arrangement E**

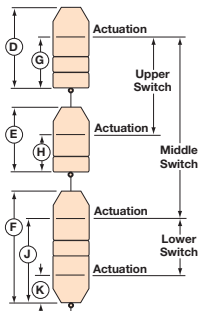

**Model C10
Displacer
Arrangement G**

C10 STANDARD ACTUATING LEVELS AND LIQUID SPECIFIC GRAVITY WITH DISPLACER ARRANGEMENTS D AND F

Displacer Type	Liquid Temp. °F	0.58				0.60				0.70				0.80			
		G	H	J	K	G	H	J	K	G	H	J	K	G	H	J	K
Porcelain	100	—	—	—	—	—	—	—	—	7.50 (190)	2.60 (66)	2.20 (55)	2.00 (50)	6.90 (175)	2.40 (60)	1.90 (48)	1.70 (43)
Stainless Steel or Karbate	100	9.90 (251)	3.70 (93)	3.20 (81)	2.30 (58)	9.20 (233)	3.20 (81)	3.00 (76)	2.20 (55)	8.90 (226)	3.80 (96)	2.10 (53)	1.90 (48)	6.70 (170)	2.20 (55)	1.30 (33)	1.70 (43)
	200	—	—	—	—	—	—	—	—	—	—	—	—	7.40 (187)	2.90 (73)	2.50 (63)	2.30 (58)

Displacer Type	Liquid Temp. °F	0.90				1.00				1.10				1.20			
		G	H	J	K	G	H	J	K	G	H	J	K	G	H	J	K
Porcelain	100	6.60 (167)	2.80 (71)	2.70 (68)	1.50 (38)	5.20 (132)	1.80 (45)	2.10 (53)	1.40 (35)	6.10 (154)	3.00 (76)	2.50 (63)	1.20 (30)	5.00 (127)	2.10 (53)	2.10 (53)	1.10 (27)
	200	—	—	—	—	6.20 (157)	3.10 (78)	2.80 (71)	1.70 (43)	5.20 (132)	2.10 (53)	2.30 (58)	1.60 (40)	—	—	—	—
Stainless Steel or Karbate	100	7.20 (182)	3.20 (81)	2.50 (63)	1.50 (38)	5.50 (139)	1.90 (48)	1.80 (45)	1.30 (33)	6.40 (162)	3.20 (81)	2.50 (63)	1.30 (33)	5.20 (132)	2.20 (55)	1.90 (48)	1.20 (30)
	200	7.60 (193)	3.60 (91)	1.70 (43)	2.00 (50)	5.90 (149)	2.30 (58)	1.10 (27)	1.80 (45)	—	—	—	—	—	—	—	—
	300	7.00 (177)	3.00 (76)	2.40 (60)	2.70 (68)	5.40 (137)	1.80 (45)	1.70 (43)	2.40 (60)	—	—	—	—	—	—	—	—

Note: All levels $\pm 0.25"$ (6).

C10 STANDARD ACTUATING LEVELS AND LIQUID SPECIFIC GRAVITY WITH DISPLACER ARRANGEMENTS E AND G

Displacer Type	Liquid Temp. °F	0.58				0.60				0.70				0.80			
		G	H	J	K	G	H	J	K	G	H	J	K	G	H	J	K
Porcelain	100	—	—	—	—	—	—	—	—	2.50 (63)	2.20 (55)	5.80 (147)	1.90 (48)	2.30 (58)	2.00 (50)	5.50 (139)	2.10 (53)
Stainless Steel or Karbate	100	4.50 (114)	3.70 (93)	7.70 (195)	2.80 (71)	3.80 (96)	3.20 (81)	7.50 (190)	2.70 (68)	4.20 (106)	3.80 (96)	6.60 (167)	2.50 (63)	1.80 (45)	2.20 (55)	5.80 (147)	2.20 (55)
	200	—	—	—	—	—	—	—	—	—	—	—	—	3.20 (81)	2.90 (73)	7.00 (177)	3.40 (86)

Displacer Type	Liquid Temp. °F	0.90				1.00				1.10				1.20			
		G	H	J	K	G	H	J	K	G	H	J	K	G	H	J	K
Porcelain	100	3.00 (76)	2.40 (60)	6.30 (160)	3.20 (81)	1.40 (35)	1.40 (35)	5.70 (144)	1.90 (48)	3.00 (76)	2.60 (66)	6.10 (154)	3.60 (91)	1.70 (43)	1.70 (43)	5.70 (144)	3.40 (86)
	200	—	—	—	—	3.20 (81)	2.70 (68)	6.40 (162)	3.60 (91)	1.70 (43)	1.70 (43)	5.90 (149)	3.40 (86)	—	—	—	—
Stainless Steel or Karbate	100	3.10 (78)	3.20 (81)	7.00 (177)	3.80 (96)	1.30 (33)	1.90 (48)	6.30 (160)	3.40 (86)	3.10 (78)	3.20 (81)	7.00 (177)	4.40 (111)	1.60 (40)	2.20 (55)	6.40 (162)	4.00 (101)
	200	3.60 (91)	3.60 (91)	6.20 (157)	3.00 (76)	1.70 (43)	2.30 (58)	5.60 (142)	2.70 (68)	—	—	—	—	—	—	—	—
	300	3.40 (86)	3.00 (76)	6.90 (175)	3.70 (93)	1.60 (40)	1.80 (45)	6.20 (157)	3.30 (83)	—	—	—	—	—	—	—	—

Note: All levels $\pm 0.25"$ (6).

SPECIFICATIONS

MODEL C15 DIMENSIONAL DATA AND ACTUATION LEVELS

INCHES (MM)

OUTLINE DIMENSIONS				
Displacer Type	Threaded Mounting		Flanged Mounting	
	A	B	A	B
Porcelain	7.75 (196)	125.00 (3175)	9.75 (247)	127.00 (3225)
Stainless Steel or Karbate	7.25 (184)	124.00 (3149)	9.25 (234)	126.00 (3200)

Displacer Type	C	D	E	F
Porcelain	2.56 (65)	7.25 (184)	6.42 (163)	5.02 (127)
Stainless Steel or Karbate	2.50 (63)	9.00 (228)	7.50 (190)	6.00 (152)

Electrical Connections	
TYPE 4X/7/9, Group B:	1" NPT

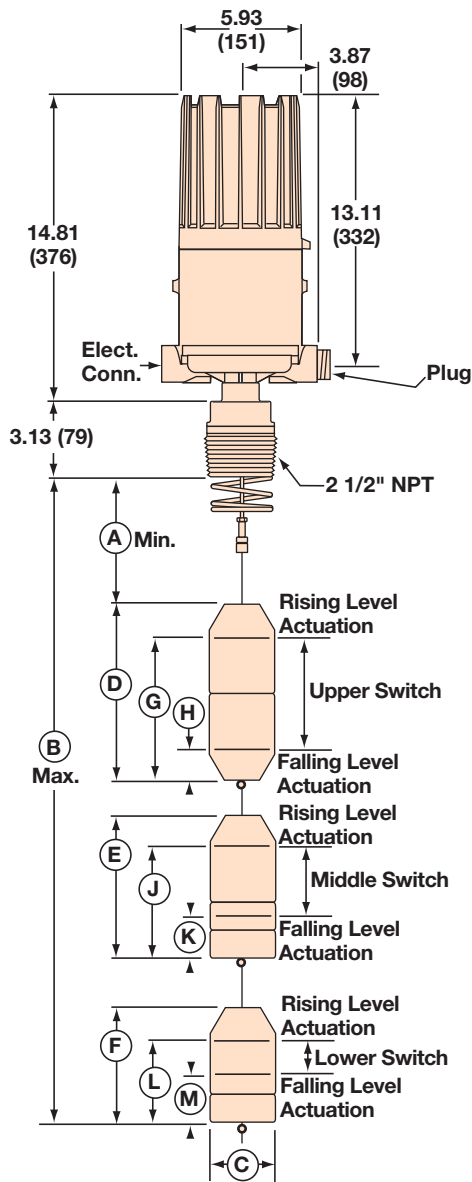

Model C15
with Threaded Mounting

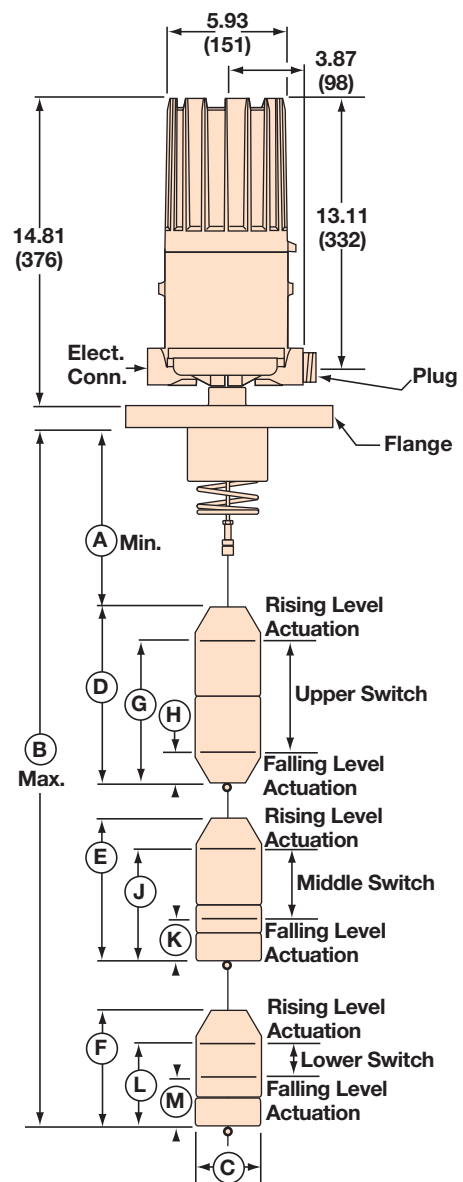

Model C15
with Flanged Mounting

SPECIFICATIONS

MODEL C15 ACTUATION LEVELS

INCHES (MM)

C15 STANDARD ACTUATING LEVELS AND LIQUID SPECIFIC GRAVITY

Displacer Type	Liquid Temp. °F	0.65						0.70						0.80					
		G	H	J	K	L	M	G	H	J	K	L	M	G	H	J	K	L	M
Porcelain	0 to +130	—	—	—	—	—	—	—	—	—	—	—	—	6.20 (157)	1.40 (35)	5.30 (134)	1.00 (25)	3.80 (96)	0.90 (22)
Stainless Steel or Karbate	0 to +130	7.70 (195)	2.20 (55)	6.10 (154)	2.00 (50)	4.90 (124)	1.40 (35)	6.70 (170)	1.60 (40)	5.50 (139)	1.60 (40)	4.60 (116)	1.30 (33)	6.50 (165)	2.00 (50)	5.20 (132)	1.60 (40)	4.30 (109)	1.10 (27)

Displacer Type	Liquid Temp. °F	0.90						1.00						1.10					
		G	H	J	K	L	M	G	H	J	K	L	M	G	H	J	K	L	M
Porcelain	0 to +130	6.20 (157)	1.90 (48)	5.00 (127)	1.40 (35)	3.60 (91)	1.00 (25)	4.60 (116)	0.70 (17)	4.00 (101)	0.80 (20)	3.30 (83)	0.90 (22)	4.20 (106)	1.10 (27)	3.80 (96)	1.00 (25)	3.10 (78)	0.90 (22)
Stainless Steel or Karbate	0 to +130	6.60 (167)	2.60 (66)	5.20 (132)	1.80 (45)	4.00 (101)	1.20 (30)	4.60 (116)	1.00 (25)	4.00 (101)	1.00 (25)	3.60 (91)	1.10 (27)	—	—	—	—	—	—

Displacer Type	Liquid Temp. °F	1.20						1.25					
		G	H	J	K	L	M	G	H	J	K	L	M
Porcelain	0 to +130	4.50 (114)	1.60 (40)	3.70 (93)	1.10 (27)	2.90 (73)	0.90 (22)	3.90 (99)	1.10 (27)	3.30 (83)	0.90 (22)	2.80 (71)	0.80 (20)

Note: All levels ±0.25" (6).

SPECIFICATIONS

PROOF-ER DIMENSIONAL DATA

INCHES (MM)

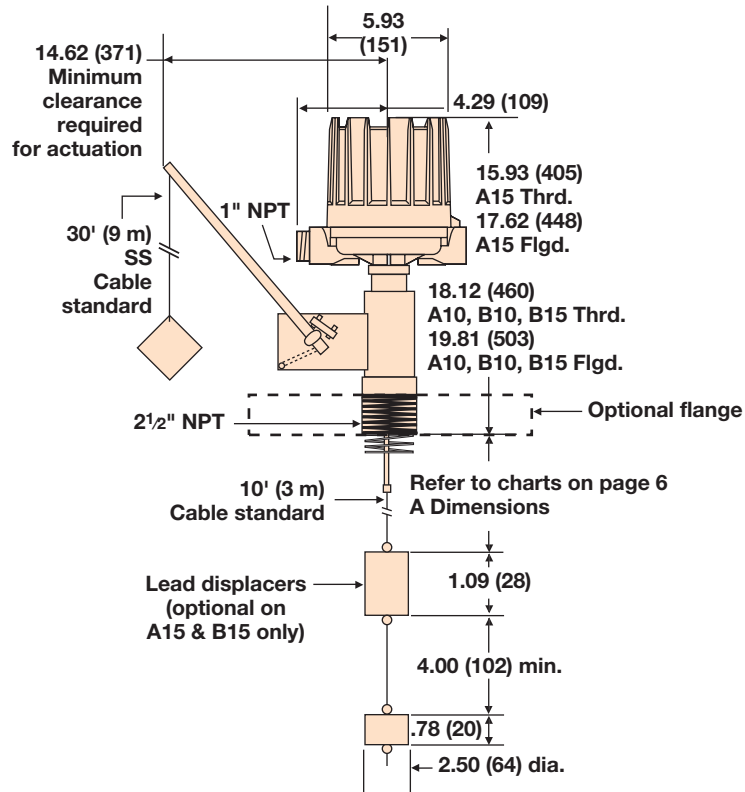

TYPICAL PROOF-ER INSTALLATION WITH VERSA FLANGE

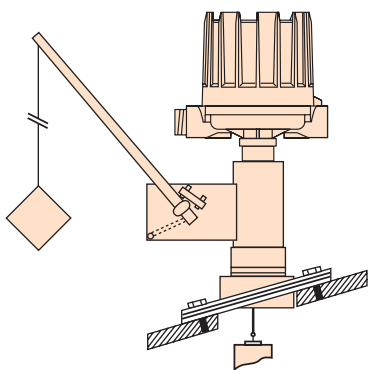

VERSA FLANGE ASSEMBLY
PART NUMBER
089-5207-001

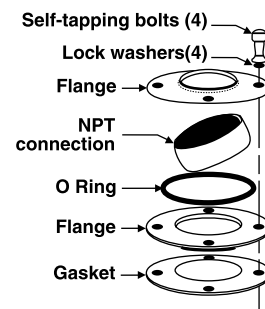

VERSA FLANGE BOLT CIRCLE

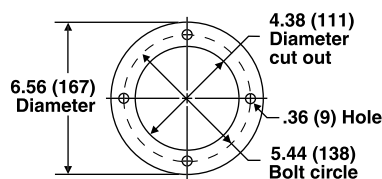

MODEL NUMBER

SERIES A10 AND A15 SINGLE SWITCH MODELS

Models available for quick shipment, usually within one week after factory receipt of a purchase order, through the Expedite Ship Plan (ESP)

PART NUMBER CODE AND SPECIFIC GRAVITY LIMITS^⑤

Part Number Code	Liquid Description	Temp.		Displacer Type		
		° F	° C	Porcelain	Stainless Steel	Karbate
A10 ^①	Wide Differential, Single Stage	100	38	0.60 to 1.20	0.60 to 1.20	0.60 to 1.20
		200	93	0.70 to 1.20	0.70 to 1.20	0.70 to 1.20
		300	149	0.80 to 1.20	0.80 to 1.20	0.80 to 1.20
		400	204	1.00 to 1.20	0.90 to 1.20	—
		500	260	1.10 to 1.20	1.00 to 1.20	—
A15	Narrow Differential, Single Stage	100	38	0.60 to 2.40	0.40 to 1.65	0.40 to 1.65
		200	93	0.62 to 2.40	0.40 to 1.65	0.45 to 1.65
		300	149	0.65 to 2.40	0.50 to 1.65	0.50 to 1.65
		400	204	0.70 to 2.40	0.55 to 1.65	—
		500	260	0.75 to 2.40	0.60 to 1.65	—

MATERIALS OF CONSTRUCTION

Code	Support Spring	Trim	E-Tube Mtg. Nut	Displacer Clamps/ Susp. Cable	Magnetic Sleeve	Process Connection
1	Inconel 600	300 Series SS	Carbon Steel	316 SS	400 Series SS	Carbon Steel ^⑥
2 ^①	Inconel 600	316 SS	316 SS	316 SS	316 SS	Carbon Steel ^⑥
4 ^①						316 SS
5 ^①	Inconel 600	300 Series SS	Carbon Steel	Monel	400 Series SS	Carbon Steel ^⑥
6 ^①				Hastelloy		
M ^{①②} NACE Const.	Inconel X750	316 SS	316 SS	316 SS	316 SS	316 SS
N ^{①②} NACE Const.	Inconel X750	300 Series SS	316 SS	316 SS	316 SS	Carbon Steel

TANK CONNECTION

Tank Connection ^③	Code
2½" NPT Threaded	E2
3" 125 lb. Cast Iron FF Flange ^{①④⑬}	G2
3" 150 lb. Steel RF Flange ^①	G3
4" 125 lb. Cast Iron FF Flange ^{④⑬}	H2
4" 150 lb. Steel RF Flange	H3
4" 300 lb. Steel RF Flange ^⑮	H4
6" 125 lb. Cast Iron FF Flange ^{④⑬}	K2
6" 150 lb. Steel RF Flange	K3
6" 300 lb. Steel RF Flange	K4

DISPLACER MATERIAL AND PROOF-ER OPTION

Proof-er Type ^⑭	Displacer Material			Floating Roof Weight Mat'l
	Porcelain	316 SS	Karbate	Lead
Without Proof-er	A	B	C	K ^④
Low Pressure	D ^④	E ^④	F ^④	L ^④
Medium Pressure	G ^④	H ^④	J ^④	—



MODEL NUMBER

SERIES A10 AND A15 SINGLE SWITCH MODELS (cont.)

Models available for quick shipment, usually within one week after factory receipt of a purchase order, through the Expedite Ship Plan (ESP)

ELECTRIC SWITCH MECHANISM AND ENCLOSURE ^①

Switch Description	Max. ^⑩ Process Temp. ° F (°C)	One Set Point	A10 Codes			A15 Codes		
			TYPE 4X/7/9 Aluminum Polymer Coated ^⑦					
			Class I, Div. 1, Groups C & D	Class I, Div. 1, Group B	ATEX Ex II 2G EEx d IIC	Class I, Div. 1, Groups C & D	Class I, Div. 1, Group B	ATEX Ex II 2G EEx d IIC
Series B Snap Switch	250 (121)	SPDT	BKB	BKK	BC9	BKQ	BKS	BA9
		DPDT	BNB	BNK	BF9	BNQ	BNS	BB9
Series C Snap Switch	450 (232)	SPDT	CKB	CKK	CC9	CKQ	CKS	CA9
		DPDT	CNB	CNK	CF9	CNQ	CNS	CB9
Series D Snap Switch For DC Current Applications	250 (121)	SPDT	DKB	DKK	DC9	DKQ	DKS	DA9
		DPDT	DNB	DNK	DF9	DNQ	DNS	DB9
Series HS Hermetically Sealed Snap Switch w/Wiring Leads	500 ^⑫ (260)	SPDT	HMJ	HMK	n/a	HMC	HEK ^⑨	n/a
		DPDT	HMS	HMT		HMF	HET ^⑨	
Series HS Hermetically Sealed Snap Switch w/Terminal Block	500 ^⑫ (260)	SPDT	HM3	HM4	HA9	HM3 ^⑧	HM4 ^⑧	HA9 ^⑧
		DPDT	HM7	HM8	HB9	HM7 ^⑧	HM8 ^⑧	HB9 ^⑧
Series F Hermetically Sealed Snap Switch	500 (260)	SPDT	FKB	FKK	FC9	FKQ	FKS	FA9
		DPDT	FNB	FNK	FF9	FNQ	FNS	FB9

PNEUMATIC SWITCH MECHANISM AND ENCLOSURE

Switch Description	Maximum Supply Pressure		Maximum Process Temperature		Bleed Orifice Diameter		A10 Codes	A15 Codes
	PSIG	Bar	° F	° C	Inches	mm	NEMA 1	NEMA 1
Series J Bleed Type Pneumatic Switch	100	7	400	204	.063	1	JGF	JDE
	60	4	400	204	.094	2	JHF	JEE
Series K Non-Bleed Pneumatic Switch	100	7	400	204	—	—	KOF	KOE

- ① Not available with displacer material and Proof-er option codes K, L.
- ② Not available with displacer material and Proof-er option codes D, E, F, G, H, and J.
- ③ Pressure/temperature ratings on page 4. Flanges are ANSI type.
- ④ Not available with material of construction codes M and N.
- ⑤ Specific gravity limits do not apply to floating roof top units, not to be used in liquid.
- ⑥ #125 flanges will be cast iron.
- ⑦ Uncontrolled housing heater or drain available in TYPE 4X/7/9 enclosures. Consult factory for standard part numbers.
- ⑧ Available with a 6" tall cover only.

- ⑨ CSA approval does not apply to Series HE switches.
- ⑩ Process temperature based on +100° F (+38° C) ambient.
- ⑪ Consult factory for TYPE 4X/7/9 cast iron housings.
- ⑫ On steam applications, temperature down rated to +400° F (+204° C) process at +100° F (+38° C) ambient.
- ⑬ Not available with material of construction code -4.

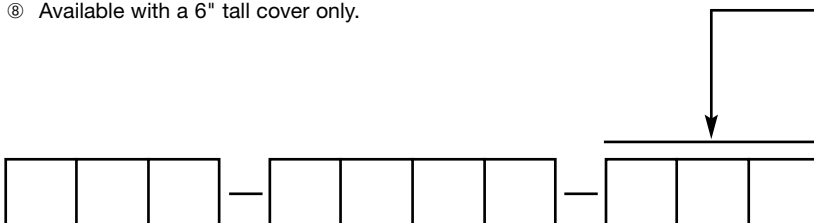

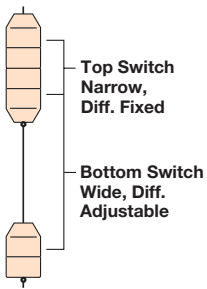

**PLUS ALARM
ARRANGEMENT NO. 1 - FILL WITH
HIGH LEVEL ALARM**

The bottom switch starts the fill cycle when the level reaches the bottom displacer. The fill cycle stops when the level rises to the top displacer. If level continues to rise, the top switch will activate an alarm.

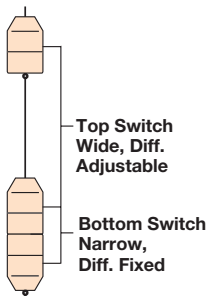

**PLUS ALARM
ARRANGEMENT NO. 2 - DRAIN
WITH LOW LEVEL ALARM**

The top switch starts the drain cycle when level rises to the top displacer. The drain cycle stops when level falls below the top of the lower displacer. If level continues to fall, the bottom switch will activate an alarm.

**CONTROL OF TWO PUMPS OF DIFFERENT CAPACITY
ARRANGEMENT NO. 3 - TWO SWITCH, WIDE
DIFFERENTIAL OR DRAIN**

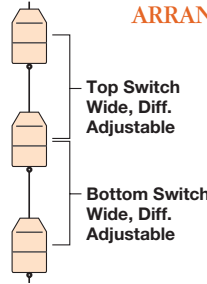

The top switch cycles with level between the top and middle displacer. The bottom switch cycles with level between the middle and bottom displacer.

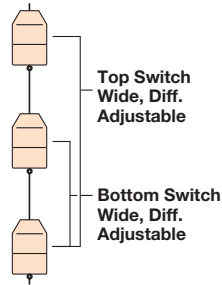

**CONTROL OF TWO PUMPS
ARRANGEMENT NO. 4**

The top switch cycles with level between the top and bottom displacer. The bottom switch cycles with level between the middle and bottom displacer.

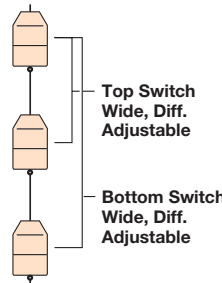

**CONTROL OF TWO PUMPS
ARRANGEMENT NO. 5**

The top switch cycles with level between the top and middle displacer. The bottom switch cycles with level between the top and bottom displacer.

ELECTRIC SWITCH MECHANISM AND ENCLOSURE 10 11

Switch Description	Max. 9 Process Temp. ° F (°C)	Two Set Points	Switch Enclosure		
			TYPE 4X/7/9 Alum Polymer Coated 7		
			Class I, Div. 1, Groups C & D	Class I, Div. 1, Group B	ATEX Ex II 2G EEx d IIC T6
Series B Snap Switch	250 (121)	SPDT	BLB	BLK	BD9
		DPDT	BOB	BOK	BG9
Series C Snap Switch	450 (232)	SPDT	CLB	CLK	CD9
		DPDT	COB	COK	CG9
Series D Snap Switch For DC Current Applications	250 (121)	SPDT	DLB	DLK	DD9
		DPDT	DOB	DOK	DG9
Series HS Hermetically Sealed Snap Switch w/Wiring Leads	500 11 (260)	SPDT	HMN	HMP	n/a
		DPDT	HMY	HMZ	
Series F Hermetically Sealed Snap Switch	500 (260)	SPDT	FLB	FLK	FD9
		DPDT	FOB	FOK	FG9

- 1 Not available with displacer material and Proof-er option codes K and L.
- 2 Not available with displacer material and Proof-er option codes D, E, and F.
- 3 Pressure/temperature ratings on page 3. Flanges are ANSI type.
- 4 Not available with material of construction codes M and N.
- 5 Specific gravity limits do not apply to floating roof top units, not to be used in liquid.
- 6 #125 flanges will be cast iron.
- 7 Uncontrolled housing heater or drain available in NEMA 4X/7/9 enclosures. Consult factory for standard part numbers.
- 8 Pneumatic switch mechanisms and enclosures are unavailable for Series B10 and B15 switches.

- 9 Process temperature based on +100° F (+38° C) ambient.
- 10 Consult factory for NEMA 4X/7/9 cast iron housings.
- 11 On steam applications, temperature down rated to +400° F (+204° C) process at +100° F (+38° C) ambient.
- 12 Not available with material of construction code -4.
- 13 Proofer in carbon steel only with all materials of construction codes.
- 14 Available only in carbon steel. Consult factory for 4" 300 lb. 316 SS flanged connection.



MODEL NUMBER

SERIES C10 AND C15 TRI-SWITCH MODELS

Note: Each C10 and C15 instrument is factory calibrated to operate for a given specific gravity within the minimum and maximum values listed.

PART NUMBER CODE AND SPECIFIC GRAVITY LIMITS

Part Number Code	Liquid Description	Temp.		Displacer Type		
		° F	° C	Porcelain	Stainless Steel	Karbate
C10†	Wide Differential, 3 switches	100	38	0.65 to 1.20	0.58 to 1.20	0.58 to 1.20
		200	93	0.95 to 1.10	0.76 to 1.00	0.76 to 1.00
		300	149	—	0.820 to 1.00	0.82 to 1.00
C15††	Narrow Differential, 3 switches	130	54	0.80 to 1.25	0.65 to 1.00	0.65 to 1.00

† When ordering C10 units, an operating sequence and operating specific gravity must be provided.

†† When ordering C15 units, an operating specific gravity must be provided.

MATERIALS OF CONSTRUCTION

Code	Support Spring	Trim	E-Tube Mtg. Nut	Displacer Clamps/ Susp. Cable	Magnetic Sleeve	Process Connection
1	Inconel 600	300 Series SS	Carbon Steel	316 SS	400 Series SS	Carbon Steel ^⑥
2	Inconel 600	316 SS	316 SS	316 SS	316 SS	Carbon Steel ^⑥
4						316 SS
5	Inconel 600	300 Series SS	Carbon Steel	Monel	400 Series SS	Carbon Steel ^⑥
6				Hastelloy		
M NACE Const.	Inconel X750	316 SS	316 SS	316 SS	316 SS	316 SS
N NACE Const.	Inconel X750	300 Series SS	316 SS	316 SS	316 SS	Carbon Steel

TANK CONNECTION AND DISPLACERS

Tank Connection ^①	Displacer Material		
	Porcelain	316 SS	Karbate
2½" NPT Threaded	E2A	E2B	E2C
3" 125 lb. Cast Iron FF Flange ^②	G2A	G2B	G2C
3" 150 lb. Steel RF Flange ^③	G3A	G3B	G3C
4" 125 lb. Cast Iron FF Flange ^②	H2A	H2B	H2C
4" 150 lb. Steel RF Flange ^③	H3A	H3B	H3C
4" 300 lb. Steel RF Flange ^③	H4A	H4B	H4C
6" 125 lb. Cast Iron FF Flange ^②	K2A	K2B	K2C
6" 150 lb. Steel RF Flange ^③	K3A	K3B	K3C
6" 300 lb. Steel RF Flange ^③	K4A	K4B	K4C

ELECTRIC SWITCH MECHANISM AND ENCLOSURE^④

Switch Description	Max. ^⑤ Process Temp. ° F (°C)	Three Set Points	Switch Enclosure	
			TYPE 4X/7/9 Aluminum Enclosure ^⑦	
			Class I, Div. 1, Groups C & D	Class I, Div. 1, Group B
Series O Snap Switch	300 (149)	SPDT DPDT	OMB	OMN
			OKB	OKN
Series Q Snap Switch	250 (121)	SPDT DPDT	QMB	QMN
			QKB	QKN

- ① Pressure/temperature ratings on page 4. Flanges are ANSI type.
- ② Not available with material of construction codes M, N and 4.
- ③ 316 SS flange is provided with material of construction code 4 and M.
- ④ Pneumatic switch mechanisms and enclosures are unavailable for Series C10 and C15 switches.
- ⑤ Process temperature based on +100° F (+38° C) ambient.
- ⑥ #125 flanges will be cast iron.
- ⑦ Consult factory for TYPE 4X/7/9 cast iron housings.



SPECIFICATIONS

MODEL C10 DISPLACER ARRANGEMENTS

INCHES (MM)

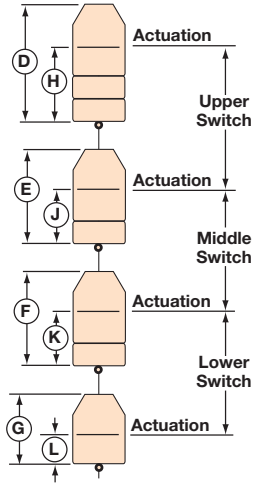

**Model C10
Displacer Arrangement A**

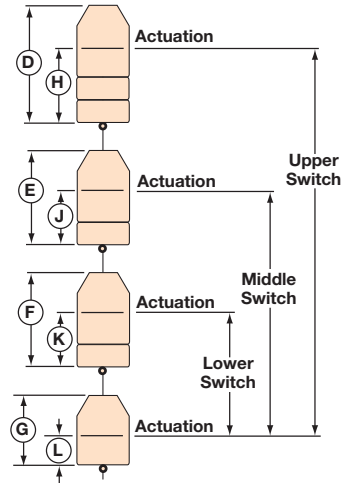

**Model C10
Displacer Arrangement B**

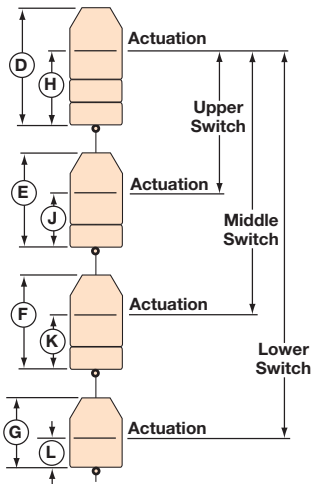

**Model C10
Displacer Arrangement C**

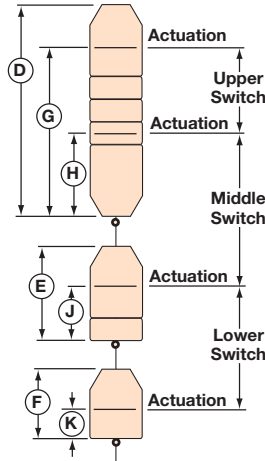

**Model C10
Displacer Arrangement D**

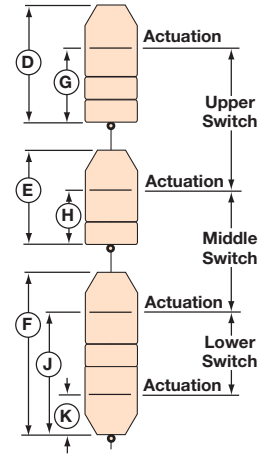

**Model C10
Displacer Arrangement E**

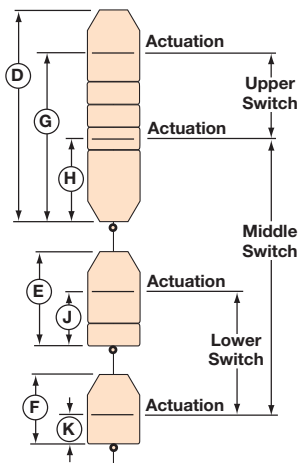

**Model C10
Displacer Arrangement F**

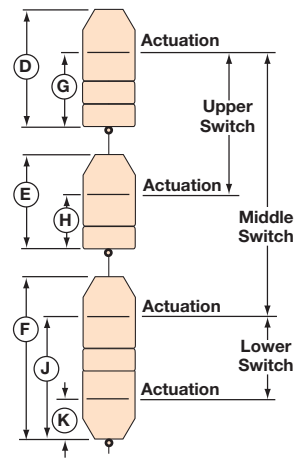

**Model C10
Displacer Arrangement G**

QUALITY

MAGNETROL
REGISTERED TO
ISO 9001
Your Assurance of
Quality and Service

The quality assurance system in place at Magnetrol guarantees the highest level of quality throughout the company. Magnetrol is committed to providing full customer satisfaction both in quality products and quality service.

Magnetrol's quality assurance system is registered to ISO 9001 affirming its commitment to known international quality standards providing the strongest assurance of product/service quality available.

ESP

Expedite
Ship
Plan

Several Displacer Type Liquid Level Switches are available for quick shipment, usually within one week after factory receipt of a purchase order, through the Expedite Ship Plan (ESP). Models covered by ESP service are conveniently color coded in the selection data charts.

To take advantage of ESP, simply match the color coded model number codes (standard dimensions apply).

ESP service may not apply to orders of ten units or more. Contact your local representative for lead times on larger volume orders, as well as other products and options.

WARRANTY



All Magnetrol mechanical level and flow controls are warranted free of defects in materials or workmanship for five full years from the date of original factory shipment.

If returned within the warranty period; and, upon factory inspection of the control, the cause of the claim is determined to be covered under the warranty; then, Magnetrol will repair

or replace the control at no cost to the purchaser (or owner) other than transportation.

Magnetrol shall not be liable for misapplication, labor claims, direct or consequential damage or expense arising from the installation or use of equipment. There are no other warranties expressed or implied, except special written warranties covering some Magnetrol products.

For additional information, see Instruction Manual, 45-610.



5300 Belmont Road • Downers Grove, Illinois 60515-4499 • 630-969-4000 • Fax 630-969-9489 • www.magnetrol.com
145 Jardin Drive, Units 1 & 2 • Concord, Ontario Canada L4K 1X7 • 905-738-9600 • Fax 905-738-1306
Heikensstraat 6 • B 9240 Zele, Belgium • 052 45.11.11 • Fax 052 45.09.93
Regent Business Ctr., Jubilee Rd. • Burgess Hill, Sussex RH15 9TL U.K. • 01444-871313 • Fax 01444-871317

Copyright © 2007 Magnetrol International, Incorporated. All rights reserved. Printed in the USA.
Performance specifications are effective with date of issue and are subject to change without notice.
Magnetrol, Magnetrol logotype & Proof-er are registered trademarks of Magnetrol International.
Monel® and Inconel® are registered trademarks of Special Metals Corporation (Formerly Inco Alloys International)
Hastelloy® is a registered trademark of Haynes International, Inc.

BULLETIN: 45-115.18
EFFECTIVE: August 2007
SUPERSEDES: March 2007